



# FORMATION MANUAL

# FORMATION MANUAL



**Not For Resale**

V 2.2.1 2009



## Dedicated to pilots everywhere who have turned swords of the Red Star in to plowshares...

Aviation in itself is not inherently dangerous. But to an even greater degree than the sea, it is terribly unforgiving of any carelessness, incapacity or neglect.

— Captain A. G. Lamplugh, London, 1930's

In flying I have learned that carelessness and overconfidence are usually far more dangerous than deliberately accepted risks.

— Wilbur Wright in a letter to his father,  
September 1900.

Beware, dear son of my heart, lest in thy new-found power thou seekest even the gates of Olympus . . . . These wings may bring thy freedom but may also come thy death.

— Daedalus to Icarus, after teaching his son  
to use his new wings of wax and feathers.

### Version 2.2.1 2009

#### Notice of Liability

The information in this manual is for reference only and the reader takes full responsibility for the use of this material. The information is presented "as is" and neither the author(s), publisher or association shall have any liability to any person or entity with respect to any loss or damage caused or alleged to be caused directly or indirectly by the instructions, information or imagery contained in this document.

#### Notice of Copyright

Copyright©2008 published by Sky Blue Prod. Inc. Principal author Drew A. Blahnick. All rights reserved. This document ("The Formation Manual") is for free download for the members of the RPA only and may not be sold, distributed or mass reproduced in any form without the prior written permission of the principal author or publisher. The person in possession of this electronically distributed document is hereby authorized to reproduce one copy by any means, commercial or otherwise for personal use. Mass reproduction is not authorized under this copyright agreement without the prior written permission of the principal author and Sky Blue Products. Inc.

#### Acknowledgments

I would like to sincerely thank the following for their vital contribution in the creation of this manual; a special thanks to the complete 2006-7 RPA check pilot roster for their patience in providing content feedback, editing and procedural analysis, the 2006-07 FAST Board of Directors for advice and input, and to several rated staff officers and flight line instructors of the United States Navy and Air Force Pilot Training Commands for their collective knowledge and experience, communicated to the author through interviews and personal visits in which unclassified assistance was gratefully provided in the interest of safety for all aviators, civilian and military trained. Digital art work by Drew Blahnick and Jed Nelson of Rama World Inc. Photography by Tyson Riniger ([www.tvrphotography.com](http://www.tvrphotography.com)). Visual signal artwork by Jim Goolsby. Basic cover design by Phil "ShortBus" Cogan and Drew Blahnick. Although it's done, it's really never finished.

# Table of Contents

---

Chapter One: ..... Formation Fundamentals

Chapter Two: ..... Two Ship Formation

Chapter Three: ..... Two Ship Rejoins

Chapter Four: ..... Extended Trail

Chapter Five: ..... Four Ship Formation

Chapter Six: ..... Abnormal Procedures

## Appendix:

Appendix A: ..... Visual Signals

Appendix B: ..... Glossary

Appendix C: ..... Briefing Procedures

Appendix D: ..... Program Forms & Documents

(POM)

# CHAPTER ONE

## Formation Fundamentals



### 1.1 Introduction

Welcome to the world of Formation Flight! This training manual is designed for students *and* qualified wingmen, flight leads and instructors. While most maneuvers have individual procedural guidance titled under “Wing” and “Lead”, pilots should become familiar with all information presented regardless of current position qualification.

The genesis of the formation flying skills and procedures presented in this training manual began in the skies over Western Europe during World War I. This was the dawn of aviation, and air forces on both sides quickly discovered that multiple aircraft working together as a coordinated team achieve far greater mission results while enhancing survivability. During this conflict, in aircraft without radio communications, the process of launching, employing and recovering ever larger numbers of aircraft required the development of effective organizational and visual communication procedures critical for safety and combat effectiveness.

Over 90 years have now passed since these first airmen began experimenting with formation flight. With time, lessons were gained from the human and material costs of both aerial warfare and peacetime training, and from this process standards and conventions have developed for effective and safe formation flying. This evolution in formation flying has progressed continually to this very day, and it is from this rich heritage we have derived the procedures and protocols provided to you in this manual.

While we do not venture in to formation flying to employ our aircraft in a combat theater, our motivations are no less fraught with the potential for personal risk. Heeding the

lessons provided to us through history, along with exercising sound judgment and self discipline, will help insure the risk is minimized. With this in mind, the contents of your training manual should be well understood before strapping in to your cockpit with the intent of beginning your formation training, and always under the supervision of an experienced formation instructor. Nothing can be more frustrating or potentially disastrous than several pilots with limited knowledge, skill, and different ideas flying in close proximity to one another. Aviation is one of the most unforgiving endeavors known to man, and formation flying is even more so.

For many pilots reading this training manual, their purpose for flying formation centers around aerial display at public airshows. However, the ultimate priorities of every formation pilot must always be the following, in the order provided:

- Safety
- Mutual support
- Symmetry/Aerial Display

This first chapter lays down the foundation for all formation flying in the RedStar Pilots Association and establishes standards that will allow members from all regions to safely operate together as one. Good luck on your journey.

### 1.2 Formation Mission Planning: Training Maneuver Limits and Operational Recommended Minimums

While maneuver guidelines and suggested restrictions are listed throughout this manual, some of the most critically important have been summarized here. The guidelines con-

tained here are not “individual invention”, but are derived from careful research of current protocols used by the United States Air Force and Navy, as well as analysis of civil formation accidents and mishaps.

While this section has been written primarily to provide the lead pilot guidance in mission planning and in-flight decision making, all formation pilots, regardless of qualification, should be familiar with this information.

This information does not guarantee the safe outcome of any flight maneuver and the final decision and authority rests with the pilot in command of the aircraft involved. If you do not feel comfortable at anytime in formation, it is up to you to cease maneuvering and communicate your concerns immediately. As with all formation maneuvers, an on-board formation flight instructor is required when the aircraft is operated by unqualified or inexperienced pilots in the maneuvers to be flown.

### 1.2.1 Parade Formation Recommended Limits

While gaining professional instruction in aerobatics, unusual attitude recoveries and spin prevention/recovery are highly recommended, a basic formation qualification resulting in the issue of a FAST Formation Card for flight in waived airspace does not require aerobatics flight or demonstrated aerobatics competency.

All parade formation maneuvering presented in this manual suggests a qualification limit of  $40 \pm 5$  degrees angle of bank (AOB) and  $15 \pm 5$  degrees of pitch for our prop aircraft. While performing at airshows in the United States, the allowable maximum maneuver limits are defined by the Federal Aviation Regulation interpretation of “aerobatics flight”, or applicable guidance provided by the Federal Aviation Administration for those pilots who do not possess aerobatics competency cards with formation endorsement or an applicable equivalent.

Wingman formation rejoin qualification in the RedStar Pilots Association requires reforming with the leader while he/she maintains a level turn at 30 degree AOB.

### 1.2.2 Fluid Maneuvering Recommended Limits

Fluid maneuvering exercises, such as Extended Trail introduced in chapter four, are training events and not evaluated items for the basic FAST Wingman qualification.

Fluid maneuvering exercises should avoid inverted flight (bank angles in excess of 90 degrees) if participating pilots have not received adequate training in aerobatics, unusual attitude recoveries and spin prevention/recovery, as well as having a full understanding of the physiological symptoms of poor G tolerance and G-Lock prevention techniques. Aircraft should be properly certified and parachutes worn by all occupants.

Flight leads should brief a hard deck when the flight plan includes extended trail, as well as review appropriate procedures in the case of a wingman losing visual with his/her leader (termed “blind”), to include the use of knock-it-off and terminate calls. See section 1.10.5 of this chapter for further guidance on lost visual procedures.

Fluid maneuvering exercises teach advanced closure control skills when flying in reference to a maneuvering aircraft in an effort to regain, or maintain, a position of mutual support. This instruction is not meant to prepare the civilian pilot to engage in simulated “dog fighting” and the information in this manual is not intended for this application. Such activity can result in death and/or loss of aircraft.

### 1.2.3 Takeoff and Landing Recommended Limits

More than 50 percent of all pilot-related accidents in general aviation occur during takeoff or landing (2006 AOPA report). Formation takeoff and landing operations are not immune to the problems faced by the general aviation community and require a high level of procedural knowledge, skill and flight discipline on the part of all formation pilots to insure safe execution.

The following guidelines deal with crosswinds, runway width, length, takeoff/landing interval and special tailwheel considerations. They are not the only guidelines for safe formation runway operations contained in applicable sections of this manual.

#### 1.2.3.1 Crosswind Guidance for Element Takeoff and/or Landing.

Crosswinds can complicate the students task during the element takeoff and landing. While each aircraft may have a different maximum demonstrated crosswind limit (refer to your Pilot Operating Handbook or Flight Manual), use interval procedures in lieu of element takeoff/landings if the cross wind component exceeds 5 knots for most RPA aircraft during initial student training. Do not conduct element takeoff or landings if a gust factor or windshear is being reported.

#### 1.2.3.2 Calculating Safe Runway Width

When conducting formation takeoff or landing operations, in which two or more aircraft are simultaneously executing the takeoff or landing roll, the runway width should allow aircraft to pass one another without undue risk of collision or departure from the prepared surface of the runway.

The recommended minimum width runway for such operations should accommodate the wingspan of both aircraft with no less than ten feet lateral separation (20 feet desired for initial student training). The aircraft should not exceed the runway edge markings in making this determination. This provides for a “clear lane” for each aircraft with the required minimum lateral separation as proscribed in the procedural guidance in this manual.

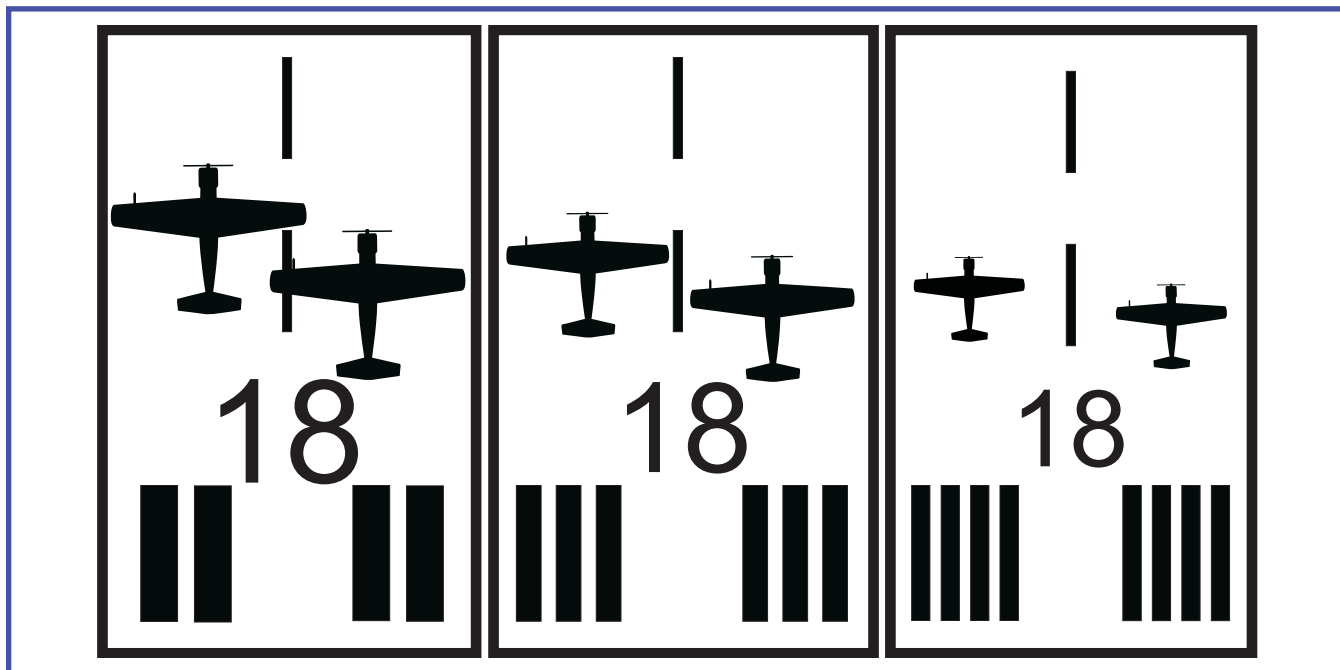

**Figure 1.1 Lateral Separation Using 60, 75 and 100 Foot Wide Runways: Typical 33 Foot Wingspan**

For most RPA aircraft such as the Yak 52, Nanchang CJ-6 and L-29/39, a minimum runway width of 100 feet should be used for formation takeoff and landings using interval or element procedures to comply with the recommended runway width criteria in this section.

**1.2.3.3 Calculating Safe Runway Length**

Formation takeoff and landing procedures may impact the distance required from normal single ship operations. The effect of multiple aircraft/elements lined up on the runway for departure, use of reduced thrust during element takeoffs, and longer than normal aim points during interval landings should be considered when conducting departure and arrival planning.

Interval takeoff procedures do not effect the takeoff distance for the individual aircraft, as reduced power is not required. If conducting an element takeoff, the use of reduced thrust/power by the lead aircraft, as well as slower than normal application of throttle (individual pilot technique) has show to lengthen takeoff roll by as much as 20% or more. Pilots are cautioned against executing element takeoffs on runways where normal calculated takeoff roll exceeds 80% of the usable runway length.

Attempting to marshal all flight aircraft on the runway prior to departure, particularly with mass formations, reduces the runway available for lead elements/aircraft. Fixed distance signs and markings will help estimate runway remaining.

Required landing distances can be significantly increased when the Flight Lead takes a longer than normal aim point for touchdown when recovering a large number of aircraft.

Using the recommended minimum landing intervals presented in this chapter will reduce the need for excessively long aim points as succeeding aircraft have ample time/distance between landing aircraft.

**1.2.3.3.1 Runway Markings**

While no pilot should become fixated on runway markings and distance remaining signs, they do provide information that may be useful to the formation pilot during runway lineup and landing rollout. Although smaller “visual” runways may have few such markings, larger runways served by instrument landing systems/approach procedures are often used by formation pilots and are equipped with several such visual aids and fixed distance to go signs.

**• Threshold Stripes**

Most public use runways in the United States and Canada have a predetermined number of threshold stripes corresponding to the width of the runway. See the table below and figure 1.1.

Runway Width:	Threshold Stripes:
60	4
75	6
100	8
150	12

**• Touchdown Zone Markings**

On precision landing runways, touchdown zone markings will start at 500 feet from the runway threshold with three broad stripes symmetrically

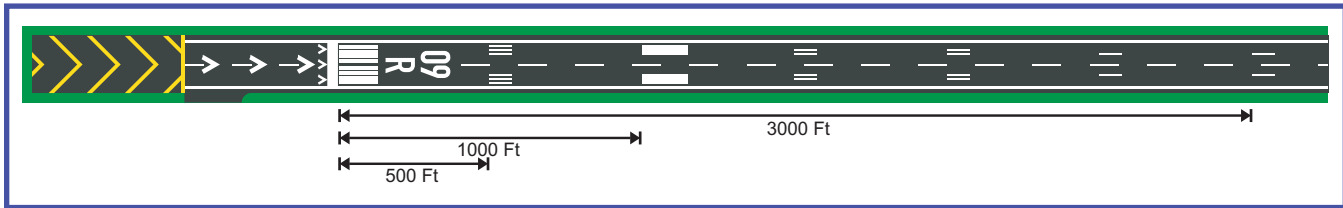

**Figure 1.2 Typical Precision Runway Markings**

arranged in pairs about the centerline. Markings will continue in 500 foot increments to 3000 feet in groups of one, two or three stripes.

#### • Runway Aim Point Markings

Runway aim point markings are large broad white stripes located on either side of the runway centerline and approximately 1000 feet from the threshold.

Such markings may be helpful to formation pilots in acceleration (time vs distance) checks, estimating distance between aircraft/elements during runway lineup, selecting extended aim points and estimating runway distance remaining.

#### 1.2.3.4 Formation Takeoff Operational Guidance

If your runway does not meet the minimum width criteria contained in section 1.2.3.2 above, the runway should be considered inadequate for element takeoffs. Nor does it provide a safe/clear lane for movement of two aircraft conducting timed interval departures should one or both abort the takeoff. Disregarding this guidance may result in an aircraft collision or forced departure from the prepared surface during a takeoff abort.

With such narrow runways, individual takeoffs should be accomplished with wingmen not releasing brakes until the preceding aircraft has reached rotation and liftoff is confirmed. If assembling multiple aircraft on the runway, pilots should steer toward the centerline as required to benefit from the full width of the runway as needed.

For runways exceeding the criteria in section 1.2.3.2, flight leads have the option of briefing an element takeoff and/or timed interval departures based on the guidance provided below and in applicable chapters of this manual.

##### 1.2.3.4.1 Timed Interval Takeoffs

Using the preceding description of “lift off” criteria between departing aircraft or elements is recommended for pilots in initial formation training, tailwheel aircraft, and is a fail-safe standard for all formation departures. However, using runways that meet the criteria in section 1.2.3.2, this manual also provides guidance on employing conservative timed intervals between departing nosewheel configured aircraft or elements.

While this section provides several important provisions/restrictions in using timed intervals that must be adhered to, the most important consideration in selection of the interval is human reaction time, *not speed of assembly*. The interval must allow each pilot sufficient time to recognize and react to a rapid or unexpected deceleration or directional control problem experienced by the preceding aircraft and maneuver accordingly. Coupled with an adequately wide runway, this allows succeeding aircraft the option of aborting straight ahead, moving to the opposite side and/or continuing the takeoff with a clear lane as the situation allows. In most cases, due to the relatively slower speed of the succeeding aircraft, aborting is the preferred option unless safety dictates otherwise.

Timed intervals should not be used in the following situations;

- Initial training of unqualified candidates.
- Tail wheel aircraft due to forward visibility restrictions during takeoff and/or abort.
- Widely dissimilar powered/configured aircraft formations due to variations in acceleration and takeoff roll.
- Runways not meeting minimum width criteria.
- Runways with less than optimal braking action.
- If the procedure was not briefed, to include applicable abort procedures.

##### 1.2.3.4.2 Minimum Recommended Takeoff Intervals

During timed interval takeoffs, the range between departing aircraft is expanding during the takeoff roll and for some time after liftoff. Timed interval departures benefit from the concept that the faster an aircraft is traveling, the faster it accelerates (up to a point), thus the rate of change in range between aircraft continues to increase during the critical phase of the takeoff roll using some interval between initiation of acceleration (brake release).

Using this concept, the minimum recommended takeoff interval proscribed below is designed to lower the risk of a wingman experiencing a high speed abort, on-runway collision or forced runway departure if the flight must abort. Using a lower takeoff interval than recommended reduces the rate of at which range expands between aircraft during the takeoff roll, reducing the safety margin built in to this procedure for no appreciable gain.



**Image 1.1 Using “Liftoff” Interval on Narrow Runways**

The intervals presented here are not intended to establish one standard operating procedure (SOP), but are the *minimum acceptable* intervals recommended in the interest of safety. Briefing shorter intervals increases the possibility of on runway collision or forced departure from the prepared surface of the runway. Flight leads’ should brief applicable departure procedures to be used every time.

The minimum recommended time between nosewheel aircraft releasing brakes during single-ship staggered interval departures is six seconds.

For element takeoffs with nosewheel aircraft, element leaders will use no less than ten seconds between departing elements. Several factors involved with element takeoffs require greater reaction time, to include:

- Difficulty in detecting collapsing range in pure pursuit.
- Lack of a “clear lane” option during element aborts. Stopping straight ahead may be the only available option.
- Close proximity of aircraft during takeoff roll. Using no less than 10 seconds insures with timely recognition, any abort by the second element will be a relatively slow speed event.

These *minimum* time criteria have been adopted from those governing USAF and US Navy formation safety protocols currently in place, both in their respective training com-

mands and operational units, for non-dissimilar nosewheel aircraft. Flight testing with our most common RPA aircraft demonstrates that, when properly executed, these intervals reduce the risk of wingman executing high speed aborts with the resultant risks (blown tires, directional control issues and on-runway collisions).

In themselves, such procedures do not guarantee safe execution of the proscribed maneuver and are based on timely recognition and action by both the aborting aircraft and those in trail. The Flight Lead should brief the departure procedure to be used based on current conditions, aircraft configuration, pilot qualification, etc. See chapter six for applicable abort procedures.

The timed interval guidance provided here and in this manual for two and four ship procedures are invalid when the formation is comprised of widely dissimilar aircraft due to variations in acceleration, takeoff roll and climb performance. In these cases, rotation/liftoff is the preferred interval.

Tailwheel configured aircraft should not employ timed interval departure procedures due to restricted forward visibility (see section 1.2.3.5).

### **1.2.3.5 Formation Landing Operational Guidance**

The same runway width criteria in section 1.2.3.2 applies to landing in either element or interval formation as well. If the runway is too narrow to support two aircraft, the flight lead should have each aircraft land on the centerline and increase the interval accordingly to provide adequate space for land-



ing and roll out. Landing aircraft should move to the exit side of the runway if space allows when safe to do so.

### 1.2.3.5.1 Interval Landing Procedures

Whether arriving to the airfield using the overhead or standard VFR pattern, during interval landings with adequate runway width, leads have a few options for recovery of the flight.

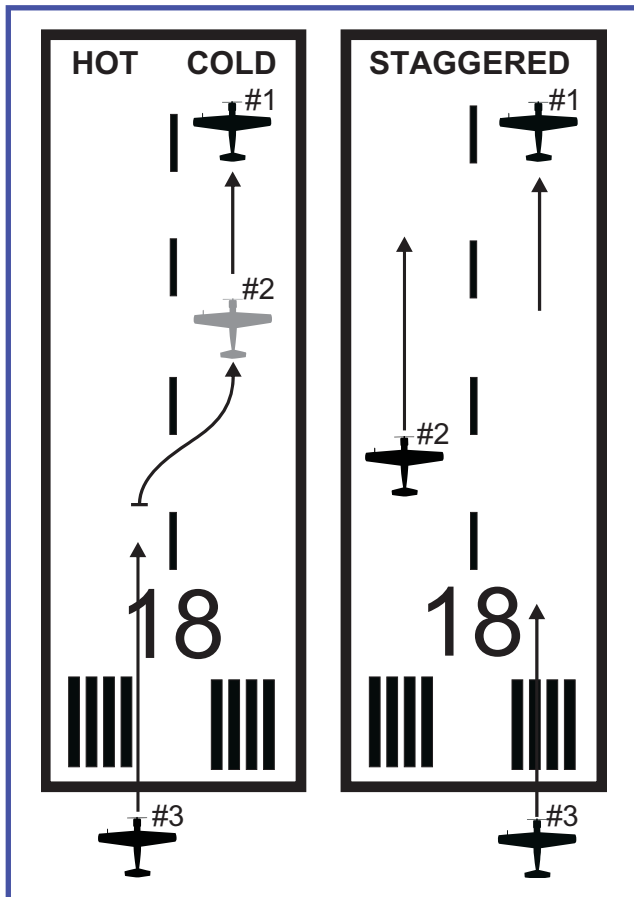

Figure 1.3 Interval Landing Options

- Hot–Cold Interval Landings:

See figure 1.3 - Left panel. Common with many air forces around the world as their preferred four-ship method of recovery, this procedure entails designating a “cold” and “hot” side of the runway. The cold side is determined by the leader who will land on the side of the runway of intended exit. The opposite side is then considered the “hot” side.

All succeeding aircraft will favor the hot side for landing, and move to the cold side as soon as practical. This procedure removes the need for coordinating between landing pilots by eliminating aircraft crossing in front of (entering the lane of) trailing flight members. Performed with adequate interval, each landing aircraft should observe a clear runway lane for landing.

As depicted in figure 1.3, this procedure reserves a “hot” lane for aircraft experiencing brake loss or other issues. This is also a good option if runway winds or other conditions call for landing on/near the centerline.

Respecting minimum recommended landing interval is crucial as all wingmen are landing directly behind one another. The interval should allow the preceding aircraft enough time to move to the cold side before the next wingman is touching down. The objective is to efficiently recover all aircraft while providing a clear lane for aircraft experiencing brake issues or requiring a go-around without requiring radio coordination. Aircraft with inadequate spacing on preceding aircraft should abort the landing.

- Staggered Interval Landings:

See figure 1.3 - Right panel. This has been the common recovery method in the RPA for some years and when conducted during two ship recoveries, is essentially identical to “hot-cold” procedures covered previously. Once again, the Flight Lead lands on the side of intended ramp exit, or “cold” side. Each succeeding aircraft however, then lands on alternating sides of the runway from one another. Aircraft landing on the opposite side of the runway as the lead aircraft will move over when cleared by the aircraft behind him/her.

The limitation in this procedure is it requires on-runway radio coordination between pilots in clearing the preceding aircraft to cross in front of (enter the lane of) the trailing wingman. Any delay in this coordination/movement, and/or if the interval between aircraft is excessively short, both lanes of the runway may become occupied with decelerating aircraft with wingmen attempting to land. (see fig. 1.4)

Likewise, if a cold side wingmen experiences brake fade/failure, he/she could be faced with both lanes of the runway ahead occupied with decelerating aircraft. As the student is ultimately being trained for mass formation flight, Flight Leads and Instructors should stress the critical importance of maintaining minimum landing interval when using this procedure.

#### 1.2.3.5.1.1 Minimum Landing Intervals

With runways wide enough, interval landings may use either option depicted in figure 1.3. During interval landings the range between flight aircraft is collapsing at an accelerating rate, as each aircraft reduces airspeed for landing, touches down and braking is initiated - all based on variable pilot technique.



**Image 1.2 Turning Final In The Nanchang CJ-6A**

For this reason, proper landing interval is generally measured between aircraft *crossing the threshold* to judge adequate reaction time and distance.

Pilots should note that the propensity for directional control problems due to such issues as brake failure, fade or tire deflation is higher on landing than takeoff. As a result, the minimum interval between landing aircraft is larger than that for departing aircraft, not smaller as provided in previous association guidance. For example, the USAF and US Navy joint pilot training program, utilizing the T-6 Texan II turboprop aircraft, requires formation takeoff intervals no less than 6 seconds between single-ship departures, while mandating staggered landing intervals of 3000 feet minimum.

The interval between landing aircraft should allow each pilot a clear lane for deceleration or sufficient time to recognize and react to an unsafe landing condition developing (such as a fouled runway caused by the preceding aircraft) and avoid a collision (move to the opposite side, abort the landing, etc.). The use of a 5 second break interval during the overhead pattern will generally allow recommended landing intervals if not compressed during the pattern.

Using either interval procedure provided in figure 1.3 above, those aircraft with approach speeds under 100 knots should

provide a *minimum* of 1500 feet between aircraft crossing the threshold. 2000 feet is preferred.

For approach speeds of 90 knots, this equates to no less than 10 seconds between aircraft (see table 1.1). Timing threshold crossing interval is only a tool in making an early decision to go-around or continue; the formation pilot is responsible for visually insuring minimum safe distance between landing aircraft is maintained.

Wingmen must understand that the interval between succeeding aircraft will collapse inside the threshold during flare, touchdown and roll out, and coupled with a loss of forward visibility due to the high angle of attack during landing, this can be a deadly situation if recommended procedures and intervals are not followed.

If landing on narrow runways that do not afford the width for both aircraft, minimum recommended interval should provide the landing aircraft a clear runway in case of brake failure with all aircraft landing on the centerline (full width).

For turbine (jet) and larger aircraft with approach speeds in excess of 100 knots, 3000 feet is recommended between staggered or hot-cold landings. This equates to approximately 15 seconds between aircraft crossing the threshold.

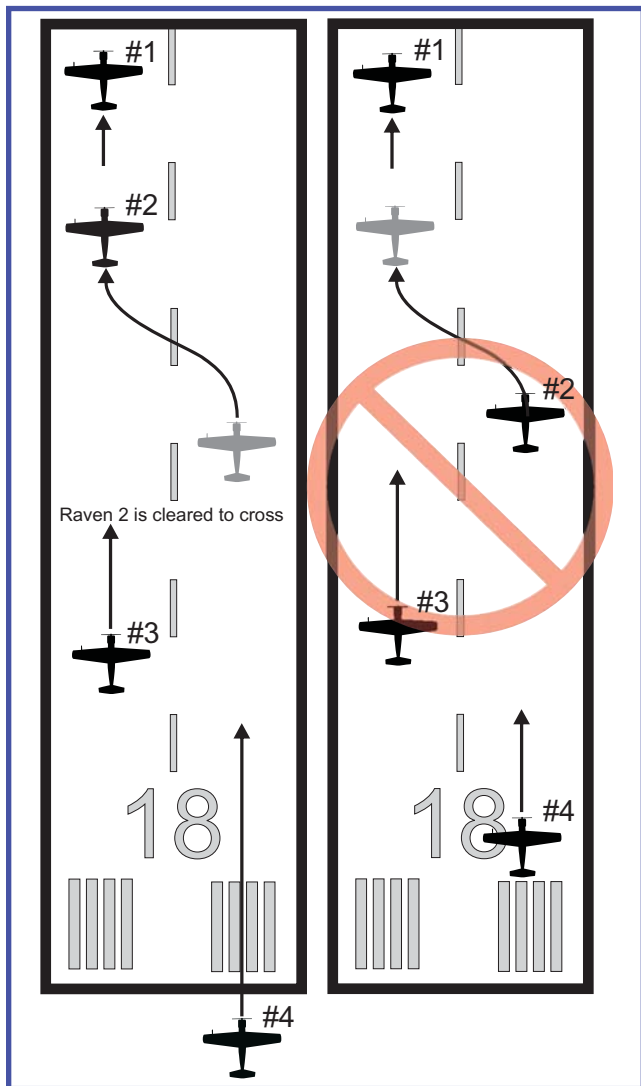

**Figure 1.4 Proper/Improper Staggered Interval**

Use 6000 feet/rollout between aircraft on narrow runways requiring centerline (full width).

Jet aircraft have considerably higher gross weights, landing speeds, required landing distance and slower thrust lever response (spool up time) that collectively results in higher recommended intervals.

Approach Speed	1000 Ft:	2000 Ft:	3000 Ft:	6000 Ft:
90 kts	7 Sec.	14 Sec.	20 Sec.	N/A
120 kts	N/A	10 Sec.	15 Sec.	30 Sec.

**Table 1.1 Approach Speed Velocity Chart**

These are minimum recommended intervals to preclude a go-around in the interest of safety, *not necessarily the desired objective*. These recommended minimums may not apply to specific tailwheel aircraft, see section 1.2.3.7 for general tailwheel guidance.

In all landing situations, if the preceding aircraft is not con-

tinually in sight during the approach, a go-around is mandatory. This may be caused by the aircraft in front “ducking under” during the final approach or the trailing aircraft flying too high on the approach path. In either case, this is a dangerous situation that can not be tolerated in formation recoveries. Such situations are unlikely when using the suggested landing intervals noted above.

**1.2.3.5.2 Element Landings**

During formation training, element landing training should be introduced only after the student has demonstrated safe parade formation flying skills. Begin takeoff and landing training with interval departure procedures.

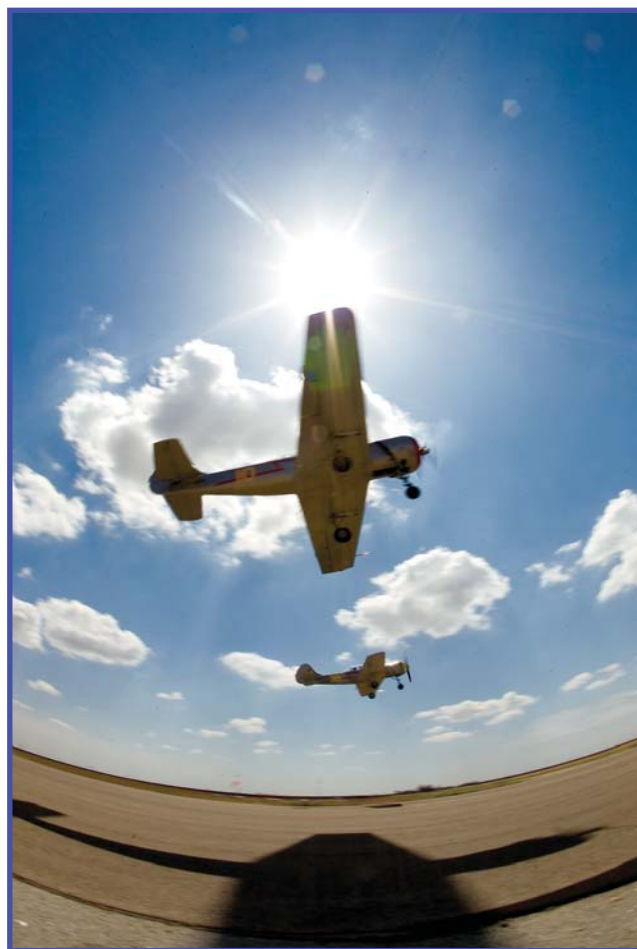

**Image 1.3 Element Landing In The Yak-52**

Element landings are not recommended with tailwheel configured aircraft. During emergency braking or other landing mishaps, the tailwheel pilots’ forward visibility is heavily restricted when all wheels are down. For this reason, tailwheel aircraft should use interval landing procedures in lieu of element landings.

Flight leads recovering multiple elements should brief an adequate interval between elements.

**1.2.3.6 General Tailwheel Guidance**

Tailwheel aircraft have additional challenges due to their

configuration limiting forward visibility during initial acceleration/takeoff roll and deceleration/landing roll. While element takeoffs may be accomplished safely, it is strongly recommended during interval departures or recoveries that the runway/runway lane is clear of maneuvering aircraft.

For takeoff, it is recommended that tailwheel aircraft should hold the takeoff roll until they are assured the preceding aircraft or element has reached rotation and lift off is confirmed.

Tailwheel element landings are **not recommended** and all recoveries should be conducted with adequate interval between aircraft to insure a clear lane for deceleration while the aircraft is in motion with the tailwheel on the runway.

### 1.2.4 Notes, Cautions and Warnings

Throughout this manual you will see information boxes labeled NOTE, CAUTION or WARNING, these perform three distinct functions:

- **Warnings:**

Warnings alert the reader to situations where injury or death may result if a process is not followed.

- **Cautions:**

Cautions are similar to Warnings, but they are used when aircraft damage may result if a process is not followed.

- **Notes:**

Notes comprise additional information or helpful techniques that aid the reader in the understanding or execution of the material presented. Additionally, we have provided guidance for formation flight instructors where needed:

- **Instructor Notes:**

This is helpful information for the backseat Formation Flight Instructor and are not safety related.

## 1.3 The Role of the Formation Instructor

Although all qualified formation Flight Leads must be capable of providing “table top” (ground) instruction in the procedures contained in this manual and in the standards published by FAST, initial formation training must be conducted under the supervision of an experienced backseat (on board) formation flight instructor.

There is no Federal requirement for this individual to be an FAA Certified Flight Instructor (CFI). However, they should possess a commanding knowledge of all standards

and procedures required of the student, while having gained adequate experience instructing formation from the perspective of the student aircraft. While former military formation instructors are highly qualified and sought after, civilian lead-rated pilots with extensive formation experience are often equally well suited for this role and should seek out training to perform this critical training function on behalf of their signatories.

### 1.3.1 Demo-Do Process

Formation flight instruction should be conducted in a “Demo-Do” process, in which each in-flight maneuver is first demonstrated by the instructor, followed by repeated execution of the maneuver by the student with instructional input, guidance and critique.

### 1.3.2 Training Records

Performance results, trends and training recommendations should be documented in some form by the instructor or flight lead and retained by the student for communication to subsequent instructors. Pilots training for their formation qualification or upgrade are often frustrated by the lack of continuity provided by signatory training. Training folders/grade sheets help address this issue and will insure the students’ training is focused appropriately. In many cases, this practice will shorten total time to qualification. See figure 1.5, the RPA Formation Training Folder.



# RedStar Pilots Association

## Basic Wing Pilot Formation Clinic Training Folder

Pilot: \_\_\_\_\_

Pilot: \_\_\_\_\_  
 Clinic 1/Date: \_\_\_\_\_  
 Clinic 2/Date: \_\_\_\_\_  
 Clinic 3/Date: \_\_\_\_\_

**ALL PILOTS MUST READ AND SIGN BEFORE BEGINNING FLIGHT TRAINING**

I hereby recognize that formation flight training and formation flying is inherently dangerous within there is a possibility of injury or death, and in consideration of my acceptance of the Formation Qualification Card/Evaluation, issued by participating Signatory Organizations, I, for myself, my heirs, executor, administrators and assigns do hereby release and forever discharge the Signatory Organization (RedStar Pilots Association) and its members, employees, suppliers, agents or representatives of and from an and all claims, demands, losses, or injuries incurred or sustained by me as a result of flights, training, attending, participating in, practicing for, and traveling to and from activities involving formation flights.

It is further understood and agreed that I, as pilot in command, by signing below, will act and retain Pilot in Command authority of my aircraft at all times during any activity while participating in any RedStar Pilots Association training, evaluation, flight training clinic, or fly-in, or anytime a member of the RedStar Pilots Association is flying in my aircraft or in a formation that includes my aircraft. At no time will an instructor on board my aircraft assume final Pilot in Command authority and responsibility regardless of who is operating the flight controls, I assume final responsibility for the actions of my aircraft.

\_\_\_\_\_  
 Pilot Signature / Date (DD/MM/YYYY)

RPA Form Training Folder/Jan 07

**Figure 1.5 RPA Training Folder and Hold Harmless**

The RPA provides training folders with grade sheets printed on the inside cover. These are available through the on-

line store at [www.flyredstar.org](http://www.flyredstar.org) or at most RPA formation clinics around the country. A one page grade sheet can also be downloaded from the website at [www.@flyredstar.org](http://www.@flyredstar.org). Training records can be discarded after successfully passing the practical test.

### 1.3.3 Pilot In Command

The student retains ultimate Pilot In Command authority at all times regardless of phase of instruction. RPA recommends all pilots sign a hold harmless agreement establishing a no-liability relationship between instructor and student before beginning flight training. RPA training folders have such an agreement pre-printed on the cover, or one can be downloaded at [www.flyredstar.org](http://www.flyredstar.org).



Image 1.4 Instructing In The L-39

### 1.4 Transfer of Aircraft Control

Formation training should not be attempted without an experienced formation instructor pilot onboard, with full access to all flight controls. Transfer of aircraft control can result in disastrous crew confusion if not accomplished properly. When the Pilot In Command (PIC) wishes to give control of the aircraft to the Instructor Pilot (IP), he/she will state over the intercom:

“You have the aircraft”

The IP will then take control of the stick/yoke, throttle and rudders, shake the stick/yoke and state:

“I have the aircraft”

The student pilot will acknowledge by relinquishing all controls and momentarily showing his/her hands. The same procedure is used to transfer control back to the student.

In rare situations, conditions may develop where the formation instructor pilot (IP), in the interest of safety, needs to take immediate control of the aircraft to avoid a possible mid-air collision. In such a case, the transfer protocol described above is not applicable—the IP will take command of the aircraft, announce control (“I have the aircraft”), and the student will *immediately* surrender control of the aircraft.

#### WARNING

See Chapter 6, *Abnormal Operating Procedures* for transfer of control during intercom failure.

### 1.5 The Formation Pilot

A successful formation flight is dependent on each flight member possessing, and expressing, solid airmanship, situational awareness and flight discipline.

Flight discipline is expressed both on the ground and in flight - it is knowing the rules, procedures and parameters, adequately preparing for the flight, recognizing in-flight deviations, and making expeditious, measured, and controlled corrections. The effectiveness, and safe outcome, of every formation flight is directly related to the airmanship and demonstrated flight discipline expressed by each member of the flight. Uncompromising flight discipline is absolutely essential to becoming a fully qualified formation pilot.

While most licensed pilots understand the concept of airmanship and flight discipline, situational awareness (SA) is often a poorly understood, yet critical element to your success as a formation pilot and eventual flight leader. The term first began appearing with pilots returning from combat in Korean and Vietnam. Here is a recent academic definition of this vital capability,

“The continuous observation of current conditions and, along with the integration of previous knowledge, the ability to quickly form a coherent mental picture to anticipate future needs and direct future actions”

Strong SA allows the formation pilot to absorb information from several different sources near simultaneously, such as the aircraft engine and navigation instruments, radio chatter, traffic analysis, etc., and anticipate what actions are needed over time.

In this regard, the concept of SA is just as critical in civilian formation flight as it was to the first jet aces of the Korea war. In formation, multiple aircraft must work as a team, where each pilot must be where they are expected to be, and when they are expected to be there, all while applying their procedural knowledge and assessment of current and anticipated conditions to decide the best course of action. This may range from a minor position adjustment of your aircraft to moving an entire mass formation. SA is a vital skill set that will grow with experience, and starts with having a strong foundation in the information presented in this training manual.

### 1.5.1 A Culture of Safety in the RPA

The Association, through regional fly-ins and such sponsored airshow programs as “RedStars, attempts to promote the flying skills and leadership of its members. For such programs to succeed, our community of pilots must promote a culture of safe formation flying in the airshow environment and around the local field. Because of the close proximity of aircraft, formation pilots have a special responsibility to ensure not only their own personal safety, but the safety of those around them.

#### 1.5.1.1 Safety Equipment

The list below is the recommended equipment for conducting formation flight. Although these items are mentioned for your safety, those marked with \* are required items to receive in-flight instruction.

- Nomex/fire retardant flight suit
- Protective footwear
- Protective gloves
- Current parachute
- Helmet
- Intercom system for two seat aircraft\*
- Instructor able to transmit outside the aircraft\*

#### 1.5.1.2 Aircraft Systems and Procedural Knowledge

In addition to having the required equipment, you should be prepared as a pilot. Proper training and currency in the aircraft to be used is a must. You should possess complete systems and procedural knowledge. Since you will only be able to take quick glances at critical engine instruments, you must readily know normal engine parameters and limitations.

Further, you must be thoroughly familiar with control and switch locations to minimize attention diverted from your formation priorities. A “blindfold cockpit check” is an excellent way to ensure familiarity with the aircraft.

#### 1.5.1.3 Knowledge of Standard Operating Procedures

It would be nearly impossible to safely gather members from all regions of North America, many having often never met one another, and execute safe precision formation without the knowledge and respect for standardized procedures.

This manual provides accurate, comprehensive procedures and safety protocols that will help each pilot succeed individually, and within the flight.

#### 1.5.1.3 Physical Preparedness

You must also be physically prepared for the hard work you will experience. Be well rested and hydrated; even experienced formation pilots will sweat! More than ordinary flying, you cannot tolerate any diminished faculties. Do not attempt to fly with impaired equilibrium or depth perception. Your fitness to fly may impact the safety of the other flight members.

### 1.5.2 Flight Lead Responsibilities

The flight lead is ultimately responsible for the safe and effective conduct of the flight. The flight lead sees to the planning of, and briefs/debriefs the flight. In training, he or she assumes the role of training officer for the mission, insuring flight members are given every opportunity to improve their skills. The flight lead position has the authority and responsibility to ensure the flight proceeds as intended.

#### 1.5.2.1 Specific Flight Lead Responsibilities

- Select wing pilots for the flight
- Verify pilots’ credentials, currency and competency in type
- Oversee the planning of all missions
- Brief and debrief each mission
- Train new formation pilots
- Endorse Formation Proficiency Reports (FPRs)
- Recommend pilots for wingman /lead check rides

As flight lead, you must monitor the wing pilot, clear the area, and plan each maneuver; all while flying a smooth, stable platform to allow the wingman to maintain position without undue difficulty. Being a good leader takes judgment, planning, and excellent situational awareness. The flight lead must be familiar with the performance limitations of all aircraft in the formation and the capabilities of the pilots within them.

### 1.5.3 Wingman Responsibilities

The three basic aspects of being a wingman are maintaining position, mutual support and formation integrity. Initially, you will spend most of your time learning to maintain position, but you should develop other skills that are integral to being a formation wing pilot.

#### 1.5.3.1 Specific Wingman Responsibilities

- Assist in the mission planning if requested
- Keep Lead in sight at all times and Maintain a constant awareness of the potential for a mid-air collision
- Maintain situational awareness and be aware

- of departure, enroute or arrival routing so you can assume the lead if required
- Monitor Lead for abnormal conditions and proper configurations at all times
- Assist during emergencies, as directed
- Monitor radio communications and assist Lead as requested
- Trust and follow Lead's direction

Strive to constantly improve and refine your formation skills. Stay mentally ahead of the aircraft and the formation to help maintain your situational awareness. Maintain radio discipline: respond promptly and concisely to required radio calls, but otherwise make only essential radio calls (imminent traffic conflict, aircraft malfunction, etc.). If you encounter difficulty while in formation, you must immediately notify Lead. Being a good wingman means doing exactly what is expected of you.

You will learn that you must not only understand, but also be able to immediately apply, formation procedures and concepts. Most importantly, you must be devoted to the safety of the formation as your first priority at all times.

## 1.6 Formation Radio Communications

All communication must be clearly understood by every flight member. Radio discipline requires not only clarity and brevity in the message, but limiting unnecessary transmissions as well. Poor radio discipline often results in frustration and a poor showing for the flight. Likewise, excellent radio procedures are often the trademark of skilled formation pilots.

The flight members are identified by a unique call sign and their respective position numbers, see figure 1.6. If the Flight Lead calls for position change, each wingman will assume the call sign number for the new position he/she is flying.

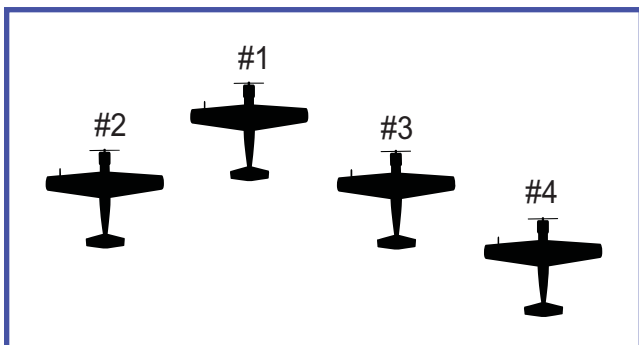

Figure 1.6 Flight of Four

### 1.6.2 Use Of Full Call Sign in Formation

Formation radio communication is actually a two-step process. The first part of any radio call is the attention or preparatory step. This step serves to alert the listener that a message is coming and to specify to whom the call is directed. Irregardless if the call is to the entire flight, or a specific wing pilot, the attention step should always contain the re-

ceiving party's full call sign (word and number) regardless of who initiates the call.

“Raven Two...”  
(receivers full word and number call sign)

Use of the full call sign when directing a specific flight member to take action insures intended recipients of critical radio calls have two means of identification (words and numbers). If there is another flight on the same frequency and the word or number is stepped on or garbled, use of full call sign will improve the chances the proper wingman will respond.

The second part is the instruction/execution step, and tells the flight member, or members, the action to be taken or information to be passed:

“...go extended trail”

The flight members should acknowledge with full call sign, and any information requested, unless briefed otherwise.

“Raven 2”

It is important to note that this basic communication procedure is not limited to calls made by the flight lead; any flight member initiating a call will use the receiver's full call sign (word and number) and the flight member the call was addressed to will respond with full call sign.

Furthermore, when announcing your independent actions, at all times, the use of full call sign and position number is warranted, as in the following example,

“Raven 2 is breaking out”

Do not grow complacent by using only position number when full call sign is called for.

#### WARNING

The acting/assigned Flight Lead should refer to him/herself in radio transmissions by full call sign and position number and avoid the use of “lead”. Reserve the use of the word “lead” for use during lead changes to preclude confusion (i.e. “Raven 1 is bingo). Wingmen will also refer to this position by number when transmitting on the radio.

### 1.6.3 Frequency Change & Check-In Procedures

All flight members must maintain the capability to communicate with one another. Frequency switching procedures and the flight check-in are critical towards this objective. When acknowledging *simple instructions in sequence*, such as frequency changes and check ins, wing pilots may use position number only, unless briefed otherwise. If acknowl-

edging such instructions out of sequence (late response, etc.), use full word and number call sign to avoid confusion with other formation aircraft that may be sharing your frequency.

### 1.6.3.1 Use of the term “Go”

When directed to change frequencies by the flight lead using the term “go”, on the ground or in the air, the flight lead will expect all flight members to acknowledge the command in sequence before leaving the frequency:

Flight lead: “Raven Flight go 121.8”

Wingman pilots acknowledgment: “2”...“3”...“4”

With all pilots responding, the entire flight will then switch to the new frequency. If one or more pilots do not respond, all pilots will remain on frequency until Lead sorts out the comm problem—once this is accomplished, the entire flight will switch to the new frequency together. The flight leader will then initiate the check-in with wing pilots responding with position number sequentially:

Flight lead: “Raven check”

Wingman pilot Acknowledgment: “2”...“3”...“4”

At this point, the leader knows that all flight members are on the same frequency and will proceed with ops transmissions. This process of check-ins and frequency change protocols will be used on the ground or in flight as briefed.

### 1.6.3.2 Use of the term “Push”

During local flying where all pilots are familiar with required frequencies, the use of a sequential acknowledgment by wingmen in response to a frequency change may not be required/desired. In these cases, the flight lead should use the term “push” instead of “go” in directing a radio change.

“Raven flight, push 118.3”

Wingman will not acknowledge this call and will switch automatically. Check in on the new frequency when requested by the Flight Lead.

#### NOTE

Regardless if using “push” or “go” procedures, the Flight Lead should always check in the flight on the new frequency. The use of “push” only alleviates the flight from checking off the old frequency.

## 1.6.1 General Radio Procedures

The procedures provided here are to be considered Standard Operating Practices (SOPs) and followed unless briefed otherwise.

## Lead

It is ultimately your responsibility to brief how radio operations will be performed during the flight; cover all deviations from the standard operating practice (SOP) contained here in your formation briefing. You speak for the flight to all agencies until the flight splits up.

Before calling for a frequency change, place the flight in route formation. Limit all maneuvering/throttle adjustments during the frequency change. Ensure all calls are clear and concise, and combine calls when practical. Although frequency changes may be called at your discretion, delay the flight check-in as needed based on wingman capabilities.

If a wingman does not respond to repeated radio calls, the wayward pilot may be experiencing radio equipment failure, simply misunderstood the frequency, or mis-channelled the radio. In these cases, you should pass the frequency via hand signals to him/her IAW Appendix A. Following the hand signals, you will once again attempt to check-in the entire flight on the radio. If the wingman is NORDO (No Radio), follow applicable procedures contained in chapter six of this manual.

#### NOTE

The flight leader will include the number of aircraft in the flight and his/her tail number on initial contact with Air Traffic Control: (AIM)

“Knoxville Ground, November Five Five Echo Mike, flight of four, taxi with information kilo”

## Wingman

Follow all basic radio procedures contained in this chapter. Respond with full call sign and position number to all directives and requests for information by the Flight Leader. When acknowledging simple instructions in sequence, such as frequency changes and check ins (covered below), wing pilots may use position number only, unless briefed otherwise.

Change radio frequency only when directed and only after all flight members have acknowledged with position number unless directed or briefed otherwise. If you do not understand the call, do not acknowledge with position number—request the frequency or applicable information be repeated (“Raven 1 - say again?”).

If Lead calls for a frequency change in flight without moving the flight to route, you should move to route position, stabilize and proceed with the channel change. Do not return to fingertip until Lead directs you, unless briefed otherwise. If you cannot hear or transmit (i.e. on-board equipment failure), follow no radio (NORDO) procedures covered in Chapter 6; Abnormal Operating Procedures. You must be familiar with the visual signals for frequency changes con-



tained in Appendix A of this manual.

## 1.7 Formation Visual Communications

Visual signals are used to the maximum extent possible to keep radio calls to a minimum. Any non-standard visual signals will be thoroughly briefed before they are used. All members of the flight must be familiar with the visual signals to be used; see appendix A for a complete list and description of both hand and aircraft signals. Normally, aircraft malfunctions or safety related issues will be communicated over the radio.

### Lead

Use visual signals in accordance with Appendix A of this manual. You will strive to make visual signals easy to see. Hand signals will be placed in the cockpit against a contrasting background to make them as visible as possible. Aircraft movements and wing-rocks will be large enough to be easily discernible. If a Wingman does not acknowledge a signal, it should be interpreted as a request for clarification. Repeat the signal or make a radio call. Do not hesitate to use the radio to avoid confusion.

### Wingman

Acknowledge Lead's hand signals with an exaggerated head nod that is easy to see. Do not acknowledge any unclear visual signals—maintain position until receiving clarification or a repeat of the signal. Lead will repeat the signal until an acknowledgment is received from you. Pass visual signals on to other wing pilots as appropriate. However, while in formation, do not look away from your leader's aircraft to pass or seek acknowledgment from other wing pilots. Do not hesitate to use the radio to avoid confusion.

## 1.8 In Flight Checks

In-flight checks include any prescribed checklists (climb, enroute, descent) for that particular aircraft as well as periodic systems and fuel quantity checks termed “ops checks” (operational checks). The ops check allows all pilots to briefly analyze fuel state, engine parameters, G-meter readings and any other parameter desired. All in-flight checks will be accomplished in route formation or when the flight is not otherwise in close formation. The flight lead will brief how fuel states will be reported, such as total time, or total fuel on board.

### Lead

You will pre-brief and direct required checklists (climb, enroute, decent) and periodic ops checks using a visual signal or radio call. Move all aircraft to route formation and avoid unnecessary maneuvering to allow wing pilots time to accomplish necessary cockpit tasks. You can also initiate an ops check when the flight is stabilized in extended trail. The use of the term “green” denotes that all briefed parameters for the check are in tolerances and the flight can proceed as briefed. After sending the flight to route, your call will sound like this:

“Raven ops check, Raven 1 is 55, green”

### Wingman

Upon receiving a radio call or visual signal for an ops check, move out to route formation if not already directed and perform the check. Continue to focus your attention on Lead, using only short glances to accomplish cockpit duties. Stay in route until Lead directs otherwise. For ops checks or fuel checks, Lead will expect you to acknowledge with total fuel remaining in time (hours/minutes), or total fuel on board.

“Raven 2, 45, green”

After the check is complete, Lead will rock you back into your original position.

## 1.9 Fuel Management

Aircraft in formation often experience un-equal fuel consumption rates so fuel management will play a vital role in mission planning and execution.

### 1.9.1 Joker Fuel

Joker fuel is the pre-briefed fuel state used to prioritize the remainder of the mission based on Lead's mission objectives. An example is terminating area work and accomplishing a recovery for multiple patterns. Upon reaching joker fuel status, the radio call is “Raven 2, Joker.” Lead will prioritize any remaining maneuvers as briefed and plan to recover the flight not later than bingo.

### 1.9.2 Bingo Fuel

Bingo fuel is a pre-briefed minimum fuel state which allows for safe return to base with necessary fuel reserves. Bingo will not be overflown, as it would preclude a safe or legal recovery. A common minimum bingo fuel for day-VFR conditions would be that required to return all aircraft to the desired destination with 30 minutes of useful reserves. In dissimilar aircraft formations, for planning purposes, the normal burn rates will not be identical among all aircraft. For this reason, Lead may brief bingo fuel in time remaining instead of pounds, gallons or liters. If an aircraft reaches bingo fuel, the required call is “Raven 2, Bingo.”

### Lead

You should carefully plan the sortie to determine appropriate joker and bingo fuel. Carefully consider briefed forecasts and current conditions, as well as other factors that may require additional fuel. In formations consisting of one aircraft type, you may brief to report fuel in total pounds, gallons or liters as the case may be.

If flying a dissimilar aircraft formation, careful consideration should be given to each aircraft's operating parameters and fuel endurance. In these cases, it is advisable to reference fuel planning in time rather than gallons/liters, etc. This may be briefed as total time remaining, or time above bingo. If in-

formed a Wingman is bingo fuel, terminate maneuvers and expeditiously begin recovery to the planned destination.

### Wingman

On the wing, you will typically burn more fuel than Lead, so monitoring fuel will be important. Lead will consider this in designing and executing the flight profile or cross country mission. However, you have the responsibility of monitoring your own fuel state. Inform the flight lead when reaching joker or bingo and get an acknowledgment.

#### CAUTION

Even if Lead hasn't called for an ops check, take other opportunities when not in close formation to look over your aircraft systems and fuel state.

## 1.10 Collision Avoidance

Each formation member shares equally the responsibility to avoid a collision. This manual can not possibly address every situation that, if mishandled, could result in an accident or incident. Nothing precludes flight members from taking whatever action is necessary to avoid a collision.

### 1.10.1 Visual Lookout and Traffic Reporting

#### Lead

You should focus on traffic, obstacle, and terrain avoidance while leading your flight. Flying in the lead position provides the most flexibility to scan visually while interpreting traffic calls from flight members or ATC. You have the additional responsibility of monitoring the progress of your wing pilots and being directive, as required, to assist them in avoiding conflicts within the flight. You should refrain from calling out traffic while in parade formation to avoid distracting your wing pilots, unless the situation poses a possible conflict.

#### Wingman

While maintaining formation, you have a primary responsibility for de-confliction between flight members. You also have standard look-out responsibilities. This is performed in parade formation by “looking through” Lead’s aircraft, beyond the flight, while not taking your eyes off Lead’s aircraft.

If traffic is spotted that may become a conflict, provide a descriptive call including clock position, elevation (high, low or level), and if estimated range.

“Raven 2 has traffic, right two o'clock slightly high,  
one mile, closing”

If the traffic is perceived as an immediate threat, make a directive call to the flight lead:

“Raven 1, turn left for traffic, now”

Follow up with a descriptive call to help lead gain visual on the traffic.

### 1.10.2 Knock-It-Off and Terminate

The procedures surrounding these two calls must be clearly understood by all formation pilots. Although their application may seem of limited use during the restricted maneuvering environment of parade formation, these terms are critical during exercises such as rejoins and extended trail, when fluid maneuvering may result in the loss of visual contact, exceeding briefed safety limits, and traffic conflicts.

#### 1.10.2.1 Knock-It-Off (KIO) Call

The term “knock-it-off” may be used by any member of the formation to direct all aircraft to cease maneuvering and will be used when **safety of flight** is a developing factor. If danger is imminent, a directive call should be made or break out executed IAW this manual. “Cease maneuvering” does not mean the flight will cease flying formation—the flight lead will decide on the appropriate course of action with the goal of providing a stable platform while clearing his/her flight path.

Following a “knock-it-off” called during rejoins and fluid maneuvering, all flight members will vigilantly clear their flight paths while terminating individual maneuvers and proceed as directed by the flight lead. For example, if the flight was in the process of executing a rejoin and the KIO call was made, all flight members would stabilize in their current position and wait for instructions from Lead.

##### 1.10.2.1.1 KIO Procedures

Initiation of a knock-it-off will begin with the flight call sign, and “knock-it-off.” If prudent, a short description of the hazard may be included such as hard deck, traffic, etc.. This call will be followed by the flight acknowledging the call, in order. In the following example, Raven flight is flying an extended trail, fluid maneuvering exercise when a member of Raven flight has realized the flight is quickly approaching the briefed hard deck (lower altitude limit for maneuvering):

“Raven flight, knock-it-off, hard deck”

“Raven 1, knock it off” (flight lead)

“Raven 2, knock it off”

“Raven 3, knock it off”

“Raven 4, knock it off”

In this example, all aircraft were alerted to a safety of flight condition that was developing. Who called KIO is not critical as the condition effected all flight members. Had the flight member witnessed imminent danger, a flight member’s pending impact with the ground in this case, the call would instead be directive in nature (“Raven 2, pull up!”).

### 1.10.2.1.2 When to Call Knock-It-Off

Transmit KIO when any of the following situations occur:

- A dangerous situation is developing
- Loss of situational awareness that can't be regained
- Violation of briefed area boundaries or flight through minimum altitudes has or is about to occur
- Recognized radio failure
- Bingo fuel inadvertently overflown such that a direct flight to primary or alternate is required
- Non-briefed or non-participating flight/aircraft enters area and is a potential hazard to the flight
- Over-G/exceeding briefed flight parameters
- Any flight member calls “knock it off”

### 1.10.2.2 Terminate Call

Call “Terminate” to direct a specific aircraft or flight to cease maneuvering and to proceed as directed. Use “terminate” when safety of flight is not a factor, or as briefed. This call is particularly useful during formation training to inform the flight lead that all desired training has been achieved for a given phase of maneuvering. Terminate may also be briefed for use in lieu of the KIO call during mass formation operations over a shared frequency to preclude impacting airshow operations outside the affected flight or aircraft.

#### 1.10.2.2.1 Terminate Procedures

##### Lead

Acknowledge the wingman's terminate request. Unless there is a safety of flight issue, the decision to continue the current maneuver is yours to make based on training requirements, fuel state, area awareness, etc.

##### Wingman

When hearing a terminate request while flying in parade formation, simply await lead's direction. When flying extended trail or during rejoins, if lead calls terminate, all flight members should acknowledge in sequence.

#### 1.10.2.2.3 When to Call Terminate

Transmit Terminate when the following situations occur:

- The desired learning objective is achieved.
- Warranted by the situation and KIO is not called for.

#### NOTE

Wingmen calling “terminate” for reasons other than safety of flight, will preface this call with “request” and await flight lead direction.

### 1.10.3 Specific Collision Risk Factors

Several factors increase the risk of mid-air collisions. You should recognize these situations and guard against them.

#### 1.10.3.1 Failure to keep the lead aircraft in sight at all times

Never move ahead of or go “belly up” to Lead's aircraft. These situations all may result in losing sight of Lead. If you lose sight in close formation, take action immediately—break out IAW the procedures in this chapter. Do not delay by attempting to regain visual contact. Ensuring separation is essential.

#### 1.10.3.2 Failure of Lead to visually monitor wing pilots during critical phases of flight such as rejoins or extended trail

As Lead, you must monitor the wing pilots. Look at the wing pilots either directly or use a mirror. Be prepared to offer assistance or take evasive action if the wingman loses sight. Direct proper actions since you may be in the best position to know where they are in relation to other aircraft. However, do not monitor the wingman to the exclusion of other duties, such as clearing for other traffic.

#### 1.10.3.3 Failure to maintain lateral or vertical separation

Whether in close formation or fluid maneuvering, as a formation pilot you are expected to be in the proper position at all times and never exceed safe limits set for lateral and/or vertical spacing. During rejoins, always maintain adequate separation until closure rates are under control and you are stabilized.

#### 1.10.3.4 Failure to recognize excessive overtake

You must learn to judge excessive closure with Lead and execute overshoots or other appropriate action when required.

#### 1.10.3.5 Failure to consider the effects of wing vortices and jet/prop wash

Vortices and prop/jet wash can be quite strong close to another aircraft. They may be encountered while performing fingertip maneuvers (particularly cross-unders) or during extended or close trail. Learn where these vortices are and avoid them. In fingertip, the vortices may cause a rolling moment into the lead aircraft. If maneuvering with higher G-loads, the vortices will be stronger and will trail up behind the lead aircraft (along Lead's flight path). Use positive control inputs to fly out of the turbulence. Break out, if needed, to ensure separation.

### 1.10.4 Formation Break Out Procedures

The purpose of a break out is to ensure immediate separation and to avoid a mid-air collision.

##### Lead

If a wingman has broken out of the flight, you may continue the current maneuver with the current power setting to aid in aircraft separation. If the wingman is in sight, you will be directive and maneuver to obtain separation based on the wing pilot's altitude call or visual contact.

**Wingman**

As the wing pilot, you must break out of the formation if you:

- Lose sight of your lead aircraft
- If you are unable to rejoin or stay in formation without crossing directly under or in front of Lead
- If you feel your presence in the formation constitutes a hazard.
- When you are directed to do so by Lead

If you have lost sight, clear, then break in the safest direction away from the last know position or flight path of Lead and other aircraft. One technique: “look for blue sky and pull” is appropriate for many situations (see caution below). Call the breakout and your altitude:

“Raven 2, breaking out, climbing to 4500 feet.”

After gaining safe separation, you should confirm that Lead is, or is not, in sight and transmit “visual”, or “blind” IAW with this chapter. If you have reacquired Lead, remain in the same general area but make no attempt to close on the flight until Lead directs you to rejoin.

**WARNING**

The wing pilot may encounter a hazardous situation in which an aggressive break out is inappropriate. For example, if the aircraft drifts into a position dangerously close to Lead, an aggressive breakout may possibly result in collision. In this situation, the wing pilot should move away from Lead, using smooth and positive control inputs.

**1.10.5 Lost Sight Procedures**

There may be cases during formation flight where you lose sight of the aircraft while maneuvering and a breakout is not warranted. This occurs when spacing between aircraft is such that a mid-air collision is not an immediate concern. An example would be losing sight after rolling out from a pitch-out several thousand feet in trail of Lead or during fluid maneuvering exercises such as extended trail.

**1.10.5.1 The Blind Aircraft**

If the other aircraft is not in sight when anticipated, and proximity does not warrant an immediate break out, the pilot will notify the flight using the term “blind”, and state altitude;

“Raven 2, blind, 4500 feet”

In some cases, heading information may be warranted, but avoid long transmissions/descriptions. If visual is regained, do not rejoin on Lead until directed to do so.

**1.10.5.2 The Visual Aircraft**

If Lead has not lost visual with the wing pilot, he/she will help the Wingman reacquire visual by transmitting his/her position from the wing pilot’s perspective.

“Raven 1 is visual, your right two o’clock high”

In this case, Raven 2 simply needs to look to his/her two o’clock high to begin reacquiring Lead.

In all cases, Lead should be directive and ensure altitude separation if required. Lead will then decide on the appropriate course of action.

**1.10.5.3 Both Aircraft Blind**

If both aircraft are blind (lost sight), the flight will immediately follow “Knock-It-Off” procedures IAW this chapter. Lead will ensure altitude separation is immediately established and maintained until making visual contact. Consult your instructor for techniques to resolve such situations efficiently.

**WARNING**

See Chapter 6, *Abnormal Operating Procedures* for guidance on inadvertent penetration of IMC and Lost Wingman procedures.

**1.11 Briefings**

The team concept of mutual support requires an effective communication process within, and among, the flight. This begins with the formal briefing and does not end until conclusion of the debriefing after the flight.

**1.11.1 Formation Briefing**

The flight lead will ensure the flight objectives, weather, sequence of events, communications and abnormal/emergency procedures are briefed before every formation flight.

Qualified formation pilots are expected to be knowledgeable of the standard operating procedures contained in this manual, thus mission elements may be briefed as “standard” provided they are published and the proficiency level of all flight members allows them to be briefed as such. Non-standard procedures and information unique to the mission will be briefed in detail.

**1.11.2 Formation Debrief**

Even though the mission is over, the learning isn’t. After everyone has had a chance to secure his/her aircraft, the flight members assemble for the debrief. This is a critical tool of the formation program. The flight lead will restate the ob-

jectives and review how the flight performed in all phases from engine start to shut down, with emphasis on what occurred, why it occurred, and how to improve in the future.

**NOTE**

See Appendix C for expanded guidance on Formation Briefing and Debriefings.



**Image 1.5 Briefing The Mission**

### **1.12 Summary**

This chapter begins the building of our Standard Operating Procedures to safely conduct formation flight training. Candidates, Wingmen, Flight Leads, Formation Instructors and Check Pilots all must have a strong working knowledge of this information to insure a safe operating environment for formation flight training and display.

## CHAPTER TWO

### Basic Maneuvers: Two-Ship Formation



#### 2.1 Introduction

This chapter will describe two ship formation fundamentals and walk through basic maneuvers from engine start to shut down. The principal target for this manual are low wing, bubble canopy, tandem seat reciprocating and turbine aircraft. Some maneuvers as described here, such as those for echelon turns, may not be applicable to solid canopy and/or high wing aircraft. Please consult a qualified instructor for specific guidance with such aircraft.

#### 2.2 Formation Organizational Terminology

Let's begin by defining the basic organizational structure of all formation flight.

##### 2.2.1 The Flight

Simply put, any group of more than one aircraft is called a "flight." A flight may consist of two aircraft, 16 aircraft or 116 aircraft all flying with respect to one another and under the direction of one designated Flight Leader.

##### 2.2.2 The Element

Flights of more than two aircraft are organized by "elements." An element consists of a Leader and a wingman. The two-ship element is the basic building block of all formation flying. There are never more than two aircraft in an element. For instance, a flight of four aircraft is made up of two elements; a flight of six is made up of three elements, and so on.

#### 2.3 Defining Fingertip Formation

The basic fingertip formation position, also commonly referred to as "parade", will form the basis for much of your

training in the RPA Formation Wingman Course. Fingertip reflects a close, "welded wing", position in which the wingman mirrors the movements of his/her lead. For purposes of two ship formation covered in this manual, Parade and Fingertip are interchangeable terms reflecting the basic position reflected in Figure 2.1.

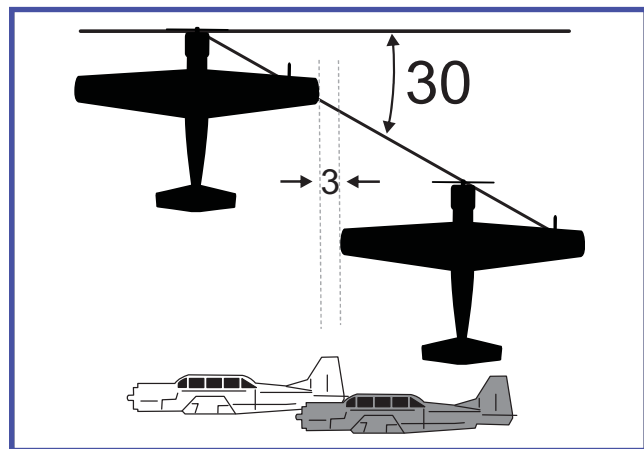

Figure 2.1 Basic Fingertip Formation Position

Fingertip formation is so named because this configuration resembles the fingertips of your hand, when viewed from above. During your four ship training, your flight will consist of two elements of two aircraft each making up a "Finger Four" configuration as covered in chapter five of this manual.

##### 2.3.1 Advantages and Disadvantages

Fingertip is often used for flight in traffic patterns, congest-

ed airspace and in flight demonstrations. However, all pilots must respect both the advantages and disadvantages inherent when choosing to operating in this configuration.

- The advantages in flying in parade formation are that it requires minimal airspace, provides good visual communication between Lead and Wingman, and presents a neat symmetrical appearance for aerial demonstrations.
- The disadvantages include less maneuverability than single ship flight, requires near constant power adjustments by the wingman, is fatiguing if conducted for long periods and inhibits proper lookout doctrine.

## 2.4 The Fingertip Position

This section will walk you through the design of a typical two ship formation. The principals here apply equally to four ship formations.

### 2.4.1 Understanding The Bearing Line

The bearing line originates at the lead aircraft's nose and extends aft at a set angle. The nose of each aircraft in the flight is aligned to this imaginary line. The angle of the bearing line will be determined for each type aircraft or group and, in general, is approximately 30° or 45°. The Nanchang CJ-6 and Yak 50/52 aircraft have chosen a 30 degree bearing line, while the Aerovodochy L-29, L-39 and most FAST signatories use a 45 degree bearing line.

When properly positioned along this bearing line, aircraft will avoid wingtip overlap as depicted in figure 2.1. As depicted, there may be some nose to tail overlap. However, all wingmen fly a slightly stepped-down position in relation to their lead aircraft and nose to tail separation is not a requirement of parade formation.

#### NOTE

Based on the exact positioning of the wingman along a 30 degree bearing line with 3-4 feet of step down, there is no requirement for nose to tail separation

The two main factors that then determine which angle is best for a given aircraft fleet are cockpit visibility and symmetry.

#### 2.4.1.1 Cockpit visibility

Much of your communication in formation will be through the use of hand signals between wingman and lead. As the wing aircraft moves aft due to a larger bearing line angle (45 degrees), nose to tail separation will increase, while ease of cockpit visibility may decrease.

#### 2.4.1.2 Formation Symmetry

The second consideration is symmetry—does the flight look balanced and pleasing to the eye when viewed by specta-

tors? Each fleet type will balance these two factors in deciding their “standard” bearing line for fingertip formation.

### 2.4.2 Use of Sightlines

With the desired bearing line angle set, next we need to determine how we can precisely position the wingman aircraft to insure minimum lateral (wingtip) separation is maintained with adequate step down for safe formation flight.

To accomplish this task in-flight, the wingman will use easily recognizable visual references, termed “sightlines” on the lead (reference) aircraft to accurately triangulate position—see figure 2.2. This tool is used by all formation pilots from the Blue Angels to RedStar, and will make the job of station-keeping much simpler. Your instructor pilot will point out several sightlines for you to use in your training.

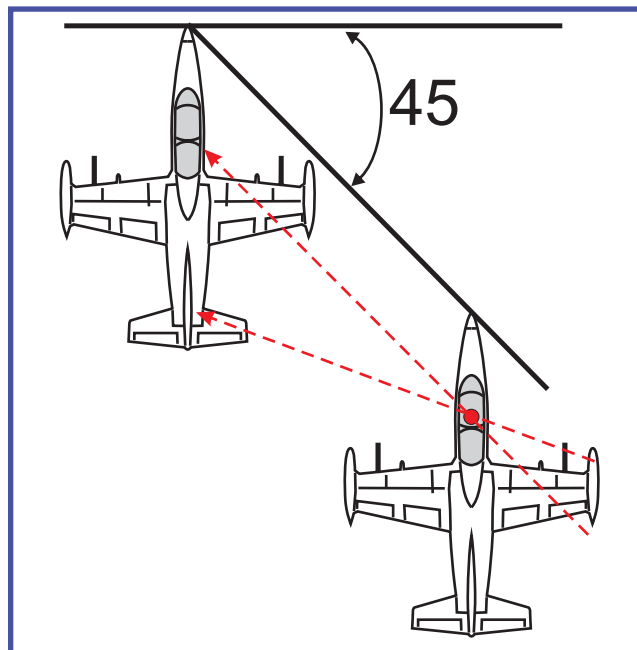

Figure 2.2 Use of Sightlines in Parade Formation

#### 2.4.2.1 Bearing Line and Lateral Separation

Ideally, the sight-lines should provide at least two points of reference on Lead to fix the wingman's position along the bearing line. One sets the angle itself, while the other sets how far “down” (or “out”) the bearing line the wingman must position his/her aircraft to produce the required minimum wingtip separation. See figure 2.2.

#### 2.4.2.2 Vertical Separation

An additional reference will provide stack-down, or vertical clearance. Most aircraft in the RPA use approximately 3 to 4 feet of step down. Again, consult your clinic instructors for type specific guidance and visual references.

#### 2.4.2.3 Sightline Use With Dissimilar Aircraft

It is important to understand that sightlines established for one aircraft may not work for another, “dissimilar”, type aircraft, as each has unique dimensions. Flight Leads will

need to cover each aircraft's unique sight-lines as part of the briefing to insure aircraft are positioned accurately along the desired bearing line. For demonstration purposes, you may position both aircraft on the ramp with 36 inches of wingtip separation as depicted in figure 2.1 and determine useful sightlines for positioning on the bearing line in flight.

## 2.5 Station Keeping in Formation

Finally, it is time to get to the nuts and bolts of formation. Maintaining position, or "station keeping," is very challenging skill to master and, in the beginning, will demand your full attention at all times. The procedures and techniques covered here will allow you to remain in a precise position at all times in formation.

### 2.5.1 Maintaining The Fingertip Position

As mentioned, your Instructor will point out the sightline references that apply to your aircraft. Do not stare at one reference. Look at the whole aircraft and clear through your Lead. Scanning from reference to reference will help you detect small changes in position.

The wingman must be constantly alert for needed corrections to position. By making small corrections early, the relative motion between aircraft remains small. If deviations are allowed to develop, required corrections become larger, and the possibility of over-correcting becomes greater.

Motion will occur along all three axes. In general, fore and aft spacing is controlled with use of the throttle; vertical position is maintained with the elevator. Lateral spacing is controlled with coordinated use of the ailerons and rudder. This is a simplified way of dividing up the control inputs and corrections.

Seldom, though, is it that easy. Most of the time, corrections will have to be combined. For instance, if you are low and apply back pressure to move up into position, you will likely fall behind unless you add power to maintain your airspeed.



Image 2.1 Fingertip Flying

Being behind the fingertip bearing line is referred to as being "sucked," while being ahead of the line is called "acute" (see fig. 2.3). When out of position, correct first to the fingertip bearing line. That way, your relative motion to the lead aircraft will always have the same appearance. The only exception to this rule is if you are too close to Lead (at or near wingtip overlap). In this case you should first obtain more lateral spacing, and then correct to the bearing line. The next most critical error to correct for is vertical position and, finally, correct for lateral spacing by moving along the bearing line toward/away from lead as the situation warrants.

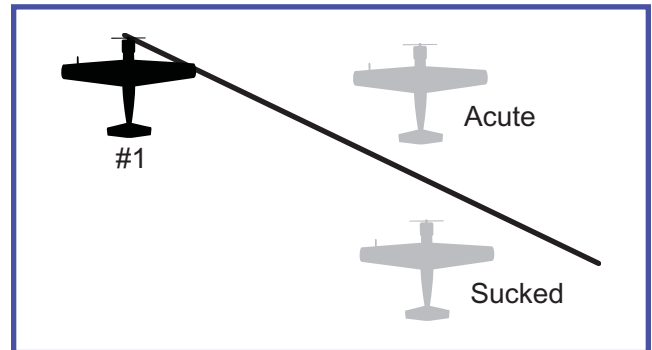

Figure 2.3 Acute and Sucked Terminology

Your instructor will have you practice exercises that help increase your judgment and teach you the corrections required to get you back into position. Always keep these points in mind:

- Relax! Just as in basic flying, you must feel what the plane is telling you. Tension leads to over-controlling, which can cause oscillations that are tough to stop
- Trim the airplane. Being out of trim increases fatigue
- Try resting your flight control arm on something stationary—like your leg, in aircraft with sticks.
- Rest your other hand on either the base of the throttle quadrant, if your aircraft is so equipped, or adjacent to the prop lever, to gauge movement and reduce over-controlling.
- Crosscheck, but do not fixate on, your sight-line reference points—look at the whole aircraft and clear through your Lead.
- Fly coordinated rudder and ailerons at all times

#### 2.5.1.1 Maneuvering In Fingertip Formation

Your "wing work", or fingertip training, will include turns up to 45 degrees of bank. All station keeping principals used in straight and level apply to maneuvering flight.

When Lead rolls into a turn, it will immediately put you out of position unless you anticipate and make the required control inputs. The wingman maintains the same relative position while rolling into and out of bank. This means that besides rolling with Lead, you have to move vertically to



stay in position. This in turn requires a power change. All this happens while Lead is rolling into the turn, but the corrections must be taken out when Lead stops rolling and is established in the bank. The effects are reversed when rolling out of the bank. We will dissect specific examples.

#### 2.5.1.1.1 Turns into the Wingman

Let's take the case where you are #2 on Lead's right side. Lead begins a smooth roll to the right. Match Lead's roll rate and bank angle. At the same time, you will need to descend to maintain vertical position. This descent will increase your airspeed, causing you to get ahead of Lead, unless you coordinate with a power reduction. This effect will be compounded by the fact that, on the inside of the turn, you are flying a smaller turn circle and will therefore travel a shorter distance than Lead.

Once Lead stops rolling and is stabilized in the bank, you will have to stop the descent and adjust power to stay in position. These are the individual control inputs explained; now how is it really done? As soon as Lead starts to roll towards you, simultaneously reduce power, roll with Lead and apply forward pressure to stay in position. See fig. 2.4.

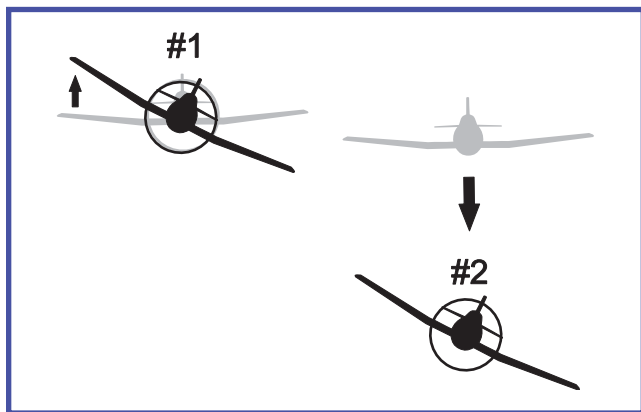

Figure 2.4 Turn In to Wingman

#### 2.5.1.1.2 Turns Away from the Wingman

Now let's look at the case where Lead turns away from you. In fingertip right, Lead starts a left turn. You will have to climb and roll to stay in position on the wing. This will require back pressure to move up vertically, and also a sizable power addition lest you lose airspeed and fall behind. Keep in mind, you are also on the outside of the turn flying a larger turn circle, and thus must increase airspeed slightly to keep with Lead. See fig. 2.5

#### 2.5.1.2 Common Errors In Station Keeping

During "turns away", it is common for new formation pilots to react too slow to Lead maneuvering. As Lead rolls in to a 30 degree bank turn, the student may be a little slow to roll, which will create excessive lateral distance from Lead as he/she turns away from the wingman. Thus, the wingman may quickly find him/her in an aft (sucked) and low position.

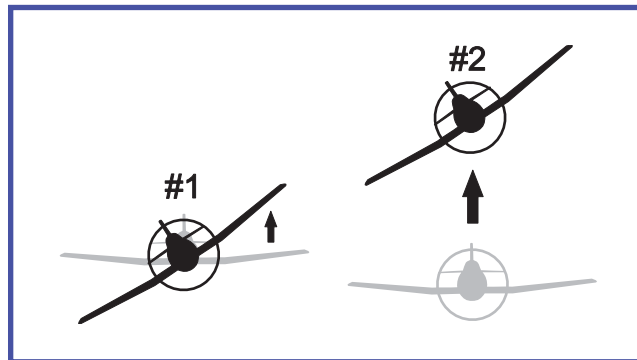

Figure 2.5 Turn Away From Wingman

In this position, with the Wingman wide, low and behind Lead, full throttle/power may be required to catch up. With time the wingman will catch back up with Lead—generally about the time Lead decides to roll out! To avoid this scenario, make positive inputs as soon as Lead rolls. Add power, stay right with Lead's roll, and ease on up to stay in position.

If you add too much power initially, it is easy to correct by taking a little off. However, it is difficult to catch back up if you are shy with the power and fall behind. Once Lead reaches his/her desired bank angle and stops his/her roll, ease off the back pressure, stabilize your bank, and adjust power to maintain position. Anticipate Lead's roll out of the bank. Lead's rolling out of the left turn will have the same effect as rolling into a right turn—it is just a turn *into* the wingman.

## 2.6 Formation Ground Procedures

With the formation briefing complete, the pilots will move to their aircraft to prepare for engine start. From this moment on, teamwork and effective communication is vital to the safety of all pilots in the flight.

### 2.6.1 Formation Engine Start and Taxi

If the aircraft are parked together, Lead will provide a visual signal for engine start; if parked separately, he/she will use a pre-briefed starting time or radio call. All aircrews should monitor the current automated weather information (ATIS or AWOS) prior to start/taxiing.

If you are late arriving at the aircraft, do not omit items on your preflight or rush engine starting procedures. Be expeditious, yet thorough, during preflight so you're ready when the flight lead needs you to be ready. If delays occur, inform the flight lead as soon as possible but not later than the pre-briefed check-in time. Inform Lead of any difficulties that may delay your departure.

#### 2.6.1.1 Aircraft Configuration

Unless briefed differently, the wingman's aircraft will be configured for flight with navigation lights and anti-collision beacon on and transponder in standby for two-ship formation. The Flight Lead will normally keep his/her anti-collision/rotating beacon off to preclude being a visual dis-

traction for the wingman. Lead will carry the transponder code for the flight and set equipment accordingly.

### 2.6.1.2 Engine Start and Check-In

Engine start based on time, visual signal or radio call as briefed by the Flight Leader. Normally, the Flight Lead will check in the flight after allowing some time for engine warm-up and/or completion of pre-taxi checks. If you are not ready for taxi at the time of check in, inform Lead. If using visual signals, when Lead looks at you, give a “thumbs up” if you are ready to taxi. After the flight checks in, Lead will call for taxi clearance, as necessary.

### 2.6.1.3 Taxi

The formation then taxis out, assuming proper position when pulling out of the parking area. Taxi position for the wingman is two ship-lengths behind Lead when taxiing staggered. Increase the spacing to four ship-lengths when taxiing directly behind Lead. Tailwheel aircraft should taxi no closer than 4 ship lengths if S-turning is required for forward visibility.

Lead should taxi at the speed that allows the wingman to attain and maintain proper spacing. As a wingman, match Lead’s configuration at all times.

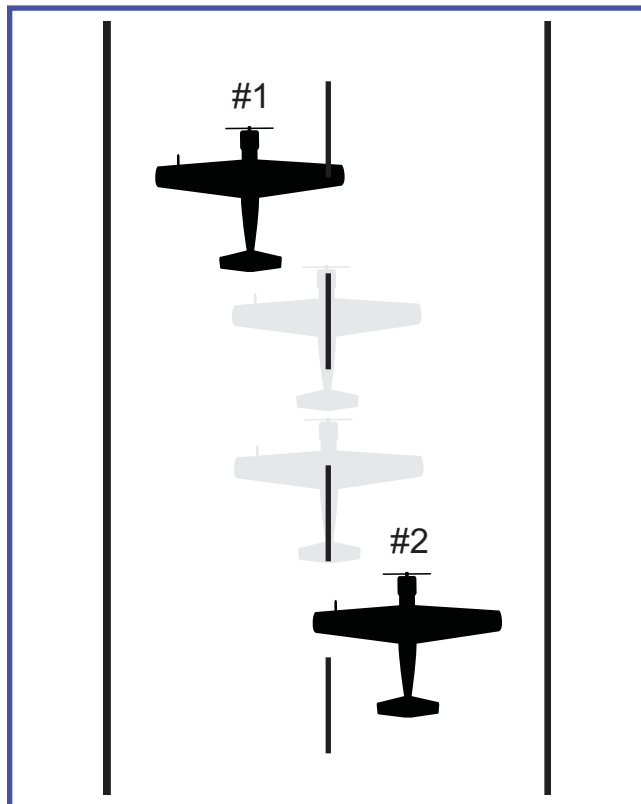

Figure 2.6 Staggered Taxi Interval

### 2.6.2 End of the Runway Lineup

Upon reaching the run-up block, number 2 should stop parallel with the flight lead. When the wingman is ready for engine run-up, he/she will signal Lead with a “thumbs up.”

Lead will signal for the run-up and both flight members will initiate their run-up procedures and complete their pre-take-off checks.

Lead and Wingman will inspect each other for proper configuration and any abnormalities as part of the run up checks. When number 2 is ready for takeoff, he/she will pass a “thumbs up” to Lead.

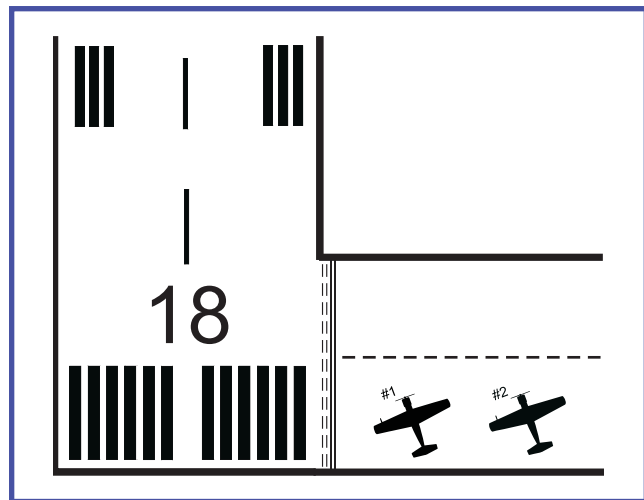

Figure 2.7 End Of Runway Lineup

## 2.7 Formation Takeoff Procedures

The two basic types of formation takeoffs covered here are the Element and Interval takeoff. During element takeoffs, the wingman maintains a parade formation position with Lead throughout the takeoff roll and climbout. Interval takeoffs on the other hand, are executed single ship, with a formation joinup after lift off.

### WARNING

All pilots should be familiar with chapter one, section 1.2 “Recommended Operational Maneuver Limits and Restrictions” pertaining to formation takeoff procedures.

### 2.7.1 Element Runway Lineup

Whether using element or interval procedures, the formation will line up on the runway as an element prior to brake release if able to do so.

#### Lead

The Flight Lead will taxi a sufficient distance down the runway to ensure his/her wingman has enough room to maneuver into position. Lead will usually take the center of his/her half of the runway, ensuring this provides a minimum of 10 feet wingtip separation. To prevent the wingman from encountering wake turbulence on takeoff, runway lineup is normally determined by the direction of the wind, with the Flight Lead positioning him/herself on the downwind side.

However, if the crosswinds are insignificant (less than five

knots of crosswind or reported calm), lead may place the wingman on the inside of the turn out of traffic or as desired for sun angle, etc.

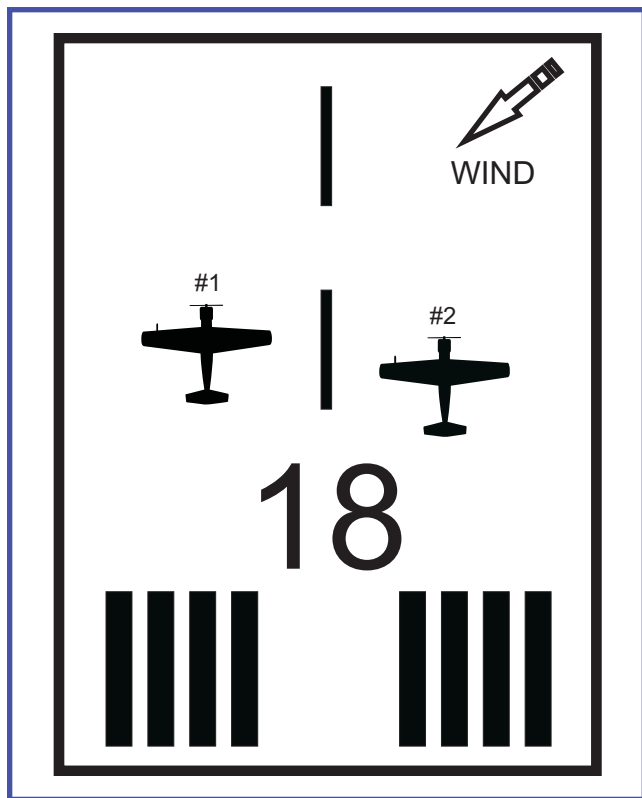

**Figure 2.8 Runway Lineup**

### Wingman

The wingman lines up in the center of his/her side of the runway, forward of the normal bearing line position with a minimum of 10 feet of lateral wingtip clearance (20 feet recommended during initial training). Once in position with brakes set and all checklists complete, the wingman will nod his/her head indicating ready for engine run/spool up. See figure. 2.8.

#### CAUTION

Most RPA aircraft are not equipped with nose wheel steering. It's important to line up parallel with lead with your nose wheel straight. Visually inspect the nose wheel of lead's aircraft as well. If required, coordinate with lead to roll straight ahead to align the nose wheel.

### 2.7.3 Interval Takeoff

Interval takeoffs are an efficient formation departure procedure and should be performed when pilot qualification, airport restrictions, winds or runway width prevent an element takeoff. The Flight Lead has the option of using staggered or centerline interval takeoff procedures based on runway width, winds and pilot capability as covered below.

#### 2.7.3.1 Staggered Interval Takeoffs

Staggered interval takeoffs require each aircraft to maintain his/her side of the runway from brake release through rotation. If the runway is wide enough to provide for both aircraft with a minimum of ten feet wingtip clearance, nose-wheel aircraft may use a timed interval between formation departures (as briefed by the flight lead). Otherwise, in all cases, wingman should not release brakes until the preceding aircraft has rotated for takeoff and lift off is assured.

While lead should brief the desired interval between aircraft, never use less than 6 seconds. This will provide approximately 300 - 500 feet of initial separation between aircraft, expanding continuously throughout the takeoff roll.

#### WARNING

Timed interval procedures are not recommended for tail wheel or widely dissimilar aircraft formations. See chapter one, section 1.2 for additional information.

If conducting timed interval takeoffs behind a low-climb capable aircraft such as the stock CJ-6A, visual with the preceding aircraft may be lost momentarily as the wingman's angle of attack is increased during initial rotation and liftoff, possibly through gear retraction. Range is generally in excess of 500 feet and continues to increase during this time. Visual should be regained immediately as the trailing aircraft angle of attack is reduced during the acceleration to climb speed and the preceding aircraft gains altitude.

#### WARNING

If visual is not regained, announce "Raven 2 is blind on Raven 1" while continuing to climb. A slight offset may be used to help acquire the preceding aircraft. Do not retard the climb, as the preceding aircraft may have experienced an engine failure or power problem and leveled off, decelerated or initiated a decent. Use altitude and flight path separation as required.

Larger aircraft, such as the L-39, should give consideration to dissimilar fuel loads/gross weights when executing timed interval takeoffs due to the disparity in acceleration rates and required takeoff roll.

If the runway does not provide the width required to accommodate both aircraft with a minimum wingtip separation of ten feet, wingmen will not release brakes until the preceding aircraft has rotated for takeoff. This is required as the runway width may not afford two clear lanes for both aircraft aborting/passing one another without an increased risk of runway collision or forced departure from the prepared surface.

However, based on runway width, an element lineup may still be accomplished with each aircraft steering to the cen-

terline of the runway after brake release as required.

### 2.7.3.2 Centerline Interval Takeoff

For narrow runways or when full width is desired, all aircraft will steer toward the centerline after brake release, or use a “feed-on” method by taking the runway individually. In all cases, with narrow runways wingmen will hold position until the preceding aircraft has rotated for takeoff and lift off is assured.



**Image 2.2 “Lift Off” Interval On Narrow Runways**

For Interval Takeoff Abort procedures, see chapter six, *Abnormal operations*.

### 2.7.3.3. General Interval Departure Procedures

#### Lead

Position both aircraft on the runway prior to initiating engine run-up and brake release unless runway width or other restrictions require a feed-on takeoff. With the wingman in position, inspect his/her aircraft for proper configuration and look for a head nod indicating he/she is ready for takeoff.

If using timed interval procedures, use all normal element takeoff procedures and signals. The wingman will simply hack the clock/begin the count instead of releasing brakes. To insure equal acceleration, both aircraft should set the briefed intermediate power setting prior to releasing brakes. Once brakes are released, each aircraft will select max/takeoff power at that time.

If using liftoff as the interval, no hand signals are required after the wingman indicates he/she is in position, as the trailing aircraft will set power at his or her discretion.

Execute a normal takeoff maintaining your side of the runway (staggered) or steer to the centerline as required. To help expedite the rejoin, climb at a reduced power setting after gear retraction or when safe to do so. Clear and monitor for your wingman during join-up.

#### Wingman

When in position and ready for takeoff, provide a head nod to the Leader after inspecting his/her aircraft for proper configuration. If using timed interval departure procedures, insure you do not shorten the interval; an on-runway mishap

is not worth a few seconds, *so always fly the briefed plan*.

If “lift off” is the briefed/required interval, delay brake release until the preceding aircraft has rotated and lift off can be assured.

Once airborne, join on the left wing for straight-ahead rejoins, or on the inside of the turn for turning rejoins. If the mission or flight requirements dictate other than above, the flight lead will pre-brief or call (while airborne) and state the desired formation position.

### 2.7.2 Element Takeoff

For most aircraft in the RPA, element takeoffs require a minimum 100 foot wide runway. Review chapter one, section 1.2.3.2, formation takeoff and landing guidance for further discussion as required.

#### Lead

Give the run-up signal when the wingman is in proper position, is looking at you in anticipation of run-up, and has given you a head nod. Set power to the briefed setting and cross-check instruments one last time. Look at the Wingman to see if he/she is ready for brake release, as indicated by a head nod.



**Image 2.3 Element Takeoff**

The execution command to release brakes is a forward deliberate head nod. As your chin hits your chest, simultaneously release brakes and, if required, smoothly advance power to the briefed takeoff power setting. Once the power is set, do not adjust the throttles unless the wingman requests it. As with a single-ship takeoff, use differential braking/nose-wheel steering until the rudder becomes effective. Perform the takeoff, concentrating on tracking straight ahead while monitoring the wingman with your peripheral vision.

To give your wingman an airspeed safety margin, you will rotate and lift off at a slightly higher airspeed than you would if you were flying single-ship (approximately five knots).

Do not retract the gear and flaps until you confirm the wingman is safely airborne, clear of obstacles, in position, and

stable. Use the standard or briefed gear retract signal.

### Wingman

When you have stopped in the proper position and are ready for run-up, look at Lead and nod your head. Acknowledge Lead's run-up signal with a head nod. During the engine run up, continue to primarily focus your attention outside the aircraft with only short glances inside the cockpit. Complete all checks. When ready for brake release, signal Lead with a head nod.

Monitor Lead for the preparatory and execution signals. Release the brakes and smoothly advance the throttle when Lead's chin hits his/her chest. In the low-speed range, tap brakes or make slight throttle adjustments as required to maintain fore and aft position. As with a single-ship takeoff, use slight differential braking/nose-wheel steering as necessary to maintain directional control until the rudder becomes effective.

Many RPA aircraft are equipped with a hand-brake system that also provides nose-wheel steering based on rudder deflection. This system may cause inadvertent steering if the rudder pedals are displaced beyond a given amount when brake pressure is applied. For this reason, avoid the excessive use of brakes during the takeoff roll.

Strive to maintain the line-up position as the aircraft accelerate for takeoff, being vigilant in maintaining your lane and not "drifting" toward Lead's aircraft. With the throttle set for takeoff, if a power/acceleration advantage or disadvantage is apparent, request one additional increase or decrease in power (e.g., "Raven 1, give me one" or "push it up").

Normally, the first indication of Lead's rotation will be the movement of the elevator/stabilator or the extension of the nose gear strut. Rotate with Lead's aircraft and concentrate on maintaining proper position while duplicating Lead's pitch attitude for lift off. A late rotation could result in overrunning Lead; an early rotation could result in falling behind.

When both aircraft are airborne, maintain a stacked-level, acute position until the gear and flaps are retracted, then move into fingertip. In the stacked-level position, the picture is the same as when lined up on the runway. Confirm the gear and flaps are retracted. If Lead lifts off before you do, do not retract the gear and flaps until you are safely airborne.

#### 2.7.2.1 Wingman Overrunning Lead

##### Lead

If the wingman moves ahead of you during the takeoff roll, insure your power is set properly and engine is operating nominally. Unless aborting the takeoff, transmit "Raven 2, you have the lead on the right/left," select takeoff power and perform an individual takeoff. Maintain aircraft separation

and direct appropriate measures to regain flight integrity.

### Wingman

With power set as briefed, if overtaking the Leader request a power increase, "Raven 1 push it up". If you still cannot prevent overrunning Lead, maintain the appropriate side of the runway, advance throttles to maximum power, and make an individual takeoff. Do not attempt to fly or maintain the wingman's position after passing Lead. Concentrate on making a single-ship takeoff. When safely airborne, retract the gear and flaps and fly the briefed departure until instructed otherwise by the flight lead.

#### 2.7.2.2 Wingman Falling Behind Lead

##### Lead

With power set, do not retard the throttles unless requested by the wingman. Be sure not to retard the throttle too far when your wingman requests "give me one". If the wingman cannot stay in position after this call, he/she will make a separate takeoff. Limit maneuvering until after you have rejoined the flight and the wingman is stabilized in position.

### Wingman

If you are behind Lead and unable to regain position, call for a power reduction (e.g., "Raven 1, give me one"). If you continue to fall farther behind following the radio call, check the throttle at maximum, ensure proper engine operation, maintain your half of the runway, and make a separate takeoff. Rejoin on Lead after becoming safely airborne and retracting the gear and flaps.

#### WARNING

For Element Takeoff Abort procedures, See Chapter Six; *Abnormal Operating Procedures*.

## 2.8 Basic Formations and Maneuvers

All two ship parade formation maneuvers required in the FAST Wingman Practical Test Guide will be covered here. Additional items requiring three and four ship formation will be covered in chapter five.

### 2.8.1 Fingertip Exercise ("Wingman Work")

Having reviewed the fingertip position and station-keeping procedures, the only thing left to do is practice. "Wingman Work" are fluid turns and lazy eight maneuvers to allow you to perfect the art of station keeping in formation. For the basic FAST Wingman qualification, wing work will include turns up to 45 degrees angle of bank (AOB) in combination with pitch changes of +/- 20 degrees.

#### Lead

Maintain a stable platform for the wingman by using smooth and consistent roll rates and avoiding sudden changes in back pressure. As an exercise fly a series of modified lazy-eight type maneuvers, increasing the angle of bank as the Wingman's proficiency improves.

### Wingman

Use all of Lead's aircraft as a reference; avoid fixating on any one spot. Use trim, small throttle and stick movements to maintain position.

Be aware of collision potential at all times. In turbulence, while flying maximum performance maneuvers or maneuvers which are not frequently flown, the collision potential increases. Under these conditions, avoid wingtip vortices because a rapid roll into the leader may develop. Should a breakout become necessary, use rudder, aileron, power, and speed brake as the situation dictates. Break out in the direction that will ensure immediate separation and follow applicable procedures contained in chapter one.

### 2.8.2 Route

Route is an extension of fingertip. In route, the flight loosens up to a minimum of two to four ship-widths out to a maximum of 500 feet from Lead. Fly no farther forward than line-abreast and no farther aft than the bearing line. Route allows the wingman to check aircraft systems and personal equipment, look around, or simply relax. It also enhances the wingman's ability to provide visual lookout for the flight.

Use two to four ship-width spacing for all frequency changes, in-flight checks, or position changes. The greater spacing allowed by route formation is used to relax, as on a cross-country flight, or to allow the wingmans to look around and help clear for traffic.

### Lead

Use a radio call or rudder walk/tail wag to send the wingman to route. With route formation, Lead should restrict maneuvering to moderate turns and pitch changes. Maximum bank angle in route is approximately 60°. Restrict all maneuvering while wingmans are conducting in-flight checks, frequency changes and other cockpit tasks.

### Wingman

Go to standard route (2-4 ship-widths) when Lead directs or gives the loosen formation signal. If lead directs/briefs route formation for an extended cross country leg, the wingman may move out the bearing line no further than 500 feet if appropriate. Avoid pulling power and sliding aft (sucked) in route, as this will require more power and time to regain the parade position when directed. Move no farther forward than line-abreast, and maintain vertical stack.

On the inside of the turn, descend only as necessary to keep Lead in sight and stay below Lead's plane of motion. When on the outside of the turn, maintain the same vertical references used in echelon. During turns, you may need to maneuver behind the bearing line to maintain spacing and keep sight of Lead. Do not cross to the opposite side unless directed by lead. Route cross-unders may be directed with a radio call or, if briefed, using a wing dip by lead.

### 2.8.3 Echelon

Echelon is a configuration where all the wing aircraft are either to the right (echelon right) or to the left (echelon left) of Lead. Due to this configuration, all planned maneuvering (turns) are away from the wingmen during echelon. Echelon provides the wingman a better power advantage to stay with Lead by remaining in the same plane during maneuvering. For the basic FAST Wingman qualification, echelon will include level turns at 45 degrees AOB.

### Lead

Indicate the use of echelon with a radio call or visual signal in accordance with appendix A. Roll smoothly in to a level turn, striving to maintain a constant load factor (G) on the airplane as required for level flight. Do not unload (reduce G abruptly) during an echelon turn. As mentioned, all planned turns are away from the wingman. If a turn must be made into the flight after signaling an echelon turn in two ship, expect the wingman to transition to standard fingertip procedures. Roll out with a smooth rate and reduce back stick pressure as the bank angle decreases.

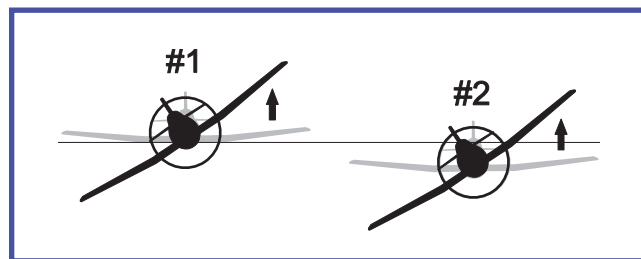

Figure 2.8 The Echelon Turn

### Wingman

All planned echelon turns will be away from the wingman. Echelon turns are accomplished differently than in fingertip. In echelon, the wingman will maintain the same lateral spacing, however they *do not* move up vertically to stay on the same lateral plane with Lead as in fingertip turns. Instead, all aircraft will roll in the same *horizontal* plane with Lead (see figure 2.8). There is a slight amount of stack-down in echelon formation, just as in straight and level parade.



Image 2.4 Echelon In The L-39

As Lead rolls into the turn, match bank angles and attempt to split the lead aircraft with the horizon line. Specific aircraft references will be demonstrated to you by your instructor. Since you are on the outside of the turn, you will be traveling a longer distance than Lead. Use power to make corrections fore and aft, back pressure to maintain horizontal spacing and bank to make corrections up or down. When Lead starts to roll out, start a power reduction as you smoothly roll back out with Lead.

If the situation requires lead to turn *in to you* after calling for/signaling an echelon turn in two ship, simply use standard fingertip turn procedures as depicted in figure 2.4.

### 2.8.4 Cross-Under

The purpose of performing a cross-under is to efficiently and safely move from one wing position to the opposite wing position. A cross-under may be accomplished from either close or route formation positions. Lead may direct a cross-under using a radio call, hand signal or aircraft signal. See below and Appendix A for further guidance on hand/aircraft signals.

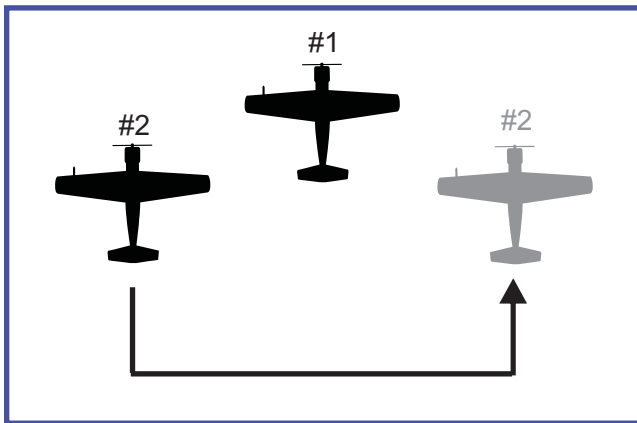

Figure 2.9 Cross-Under

#### 2.8.4.1 Cross Under Hand Signal

The Leader's hand signal for the cross-under is the forearm held vertical with a clenched fist until acknowledged by the Wingman. Hand signals are considered standard operating procedure for the RPA and will be used at all times unless briefed otherwise. See Appendix A.

#### 2.8.4.2 Cross Under Aircraft Signal

The Flight Lead may brief the use of the "Wingman Dip" for signaling a cross-under. The wing dip consists of a rapid deflection of the ailerons in the direction the Leader wishes the wingman to cross-under to. With the wingman on the left, as depicted in figure 2.9, a wing dip to the right will initiate a cross-under to the opposite side.

While the wing dip may be more recognizable while in route formation, it has been shown to cause some concern for light aircraft, having been confused with normal disturbances caused by minor turbulence/wing upset. The wing dip will

be further covered in chapter 5, four ship formation.

#### 2.8.4.1 Cross Under Execution

##### Lead

Use the cross under to place your wingman out of the line of sight of the sun, to configure for the overhead pattern and other uses as desired. Do not cross-under student pilots while maneuvering.

##### Wingman

Acknowledge the signal with a prominent head nod. Initially, perform a cross-under in three definite moves. As you gain experience with this maneuver, these steps will blend in to one fluid movement.

##### Step One: Back and Down

Reduce power slightly and, as airspeed is reduced, move a few feet lower than normal position. Move aft to obtain nose-tail clearance; then increase power slightly to maintain this spacing. (Anticipate the power increase to prevent falling too far behind.)

##### Step Two: Move Across

Bank slightly toward the new position to change the aircraft heading by a few degrees. Roll wings level, and fly to the opposite side. A heading change of only 1° or 2° will cause the aircraft to fly smoothly from one side of Lead to the other. Keep proper nose-tail clearance with power; a power increase is necessary to maintain this clearance. Do not cross directly under any part of Lead's aircraft!

##### Step 3: Move Forward and Up

When you have wingtip clearance, return to Lead's heading. Add power, and move forward and up to attain proper pitch references. As you approach the fingertip position, reduce power to stop in position.

As your skill increases, you may round out under the cross-under to execute it as one smooth maneuver. Regardless of your technique, never pass under Lead.

To fly good cross-under, you must anticipate each power change and make the smallest possible changes in pitch and bank. Once you become proficient, cross-under may be completed during turns, climbs and descents.

### 2.8.5 Close Trail

Close trail maneuvering consists of turns, climbs, descents, and modified lazy eights. Proper spacing is one aircraft ship-length, nose-to-tail, behind Lead and just below Lead's prop/jet wash (Figure 2.8). For the basic Wingman qualification, proficiency will be demonstrated up to 45 degrees AOB.

Lead signals for close trail by holding up a clenched fist, thumb extended aft, motioning aft. Alternatively, Lead can also porpoise his/her aircraft or make a radio call. Close trail

maneuvering will be terminated by either reforming to fingertip with a radio call or visual signal, or moving to extended trail (radio call only). If reforming to fingertip, Lead must avoid any significant power changes until the wingman is in fingertip. If moving to extended trail, Lead will follow extended trail entry procedures.

### Lead

Wait for the wingman to call in before maneuvering. Be smooth, predictable and maintain positive G-force at all times. Avoid sudden releases of back pressure and rapid turn reversals. In training, limit maneuvering bank angle to 45 degrees and pitch changes to +/- 20 degrees.

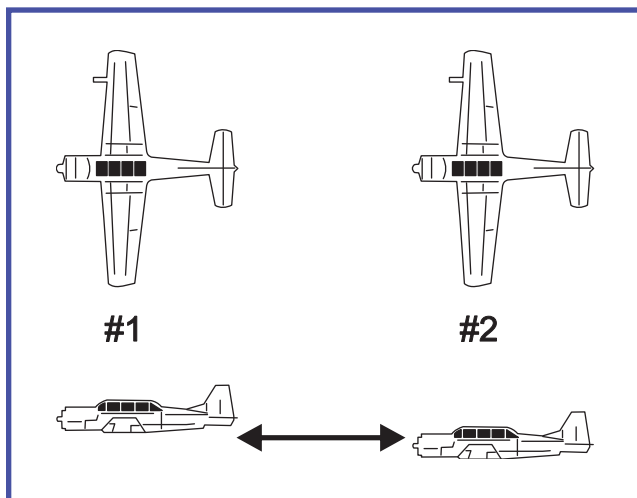

**Figure 2.10 Close Trail - One Ship length Spacing.**

### Wingman

Acknowledge the call with a head nod or radio call. Maneuver to the close trail position, and call when in position. It is critical in close trail to maintain nose to tail separation and below Lead's prop/jet wash at all times.



**Image 2.5 Close Trail In The Yak 52 TW**

Maintain position primarily through the use of power. However, when flying directly behind Lead, closure rates become difficult to determine. If excessive spacing exists and lead is maneuvering (i.e turning), do not attempt to move forward

with power alone. Use a combination of power and small amounts of lead pursuit (cut off) while in the turn. If wings-level, you may move off to one side slightly to obtain a better perspective of Lead while learning to gage pure pursuit closure.

### 2.8.6 Lead Changes

Lead will initiate a lead change with a visual signal or radio call. The "stable platform" concept is very important when executing this maneuver—the pilot giving up the lead position will remain wings level and stable while the pilot assuming lead maneuvers into position.

### Lead

Move the wingman out to route position. If using hand signals, point to the wingman and then point forward repeatedly to indicate you are transferring lead. If you are using the radio, transmit "Raven 2, you have the lead on the right/left." Maintain straight-and-level flight with a constant power setting.

### Wingman

When Lead gives you the lead-change hand signal, acknowledge with a head nod and move to route, if not already there, and then move forward towards line abreast. At line abreast, signal the surrendering lead pilot by tapping your head/helmet and pointing forward, indicating that you now have the lead.

Increase power slowly and advance forward to assume the lead position. As you move forward, the surrendering lead will pick up the normal route fingertip references and maintain station-keeping.

If a radio call is used: "Raven 2, you have the lead on the right/left," respond with full call sign ("Raven 2") and move to line abreast, route position. Once stabilized, call "Raven 2 has the lead on the left/right," increase power slowly and move forward. The new wingman will maintain route until directed by the new lead.

Once the flight is stabilized in the new configuration, the new Lead will check the flight in on the radio: "Raven, check. Raven 1". The new Wingman will respond: "Raven 2."



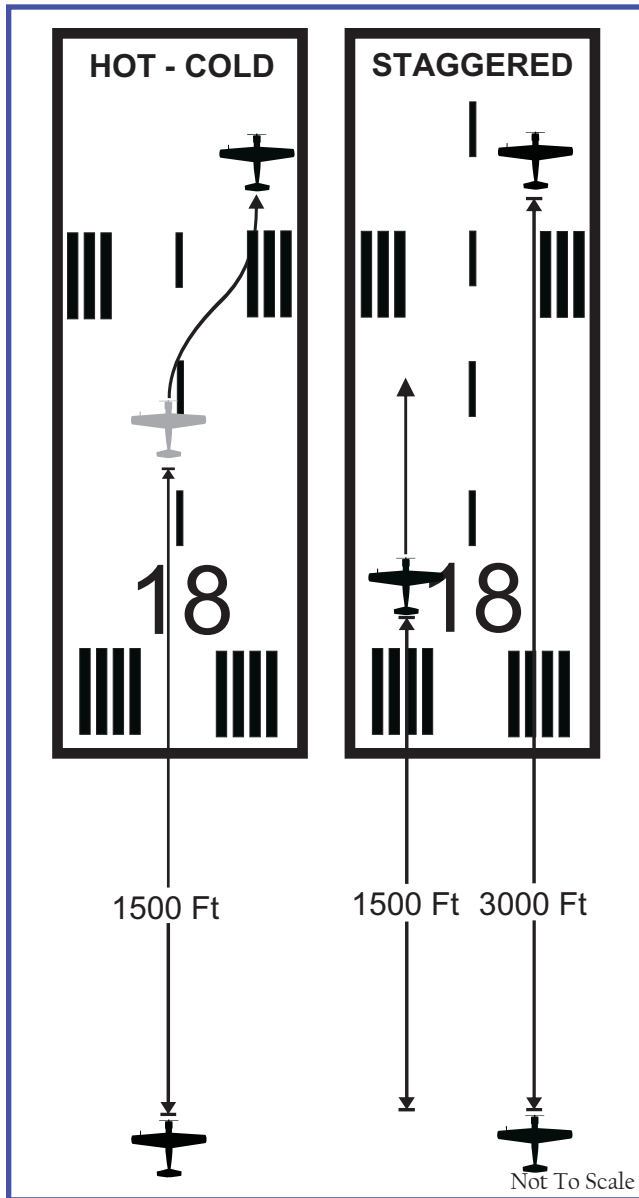

Figure 2.11 Hot-Cold and Staggered Landings: Prop

### 2.9 Formation Recovery and Landings

There are three basic options for recovering your formation; the VFR rectangular pattern, the overhead pattern and the straight in. Each will be covered in this section. Formation instrument approach procedures are beyond the scope of this manual.

**WARNING**

All pilots should be familiar with chapter one, section 1.2 “Recommended Operational Manuever Limits and Restrictions” pertaining to formation landing procedures.

The two basic types of formation recoveries we will address are the element (formation) landing and Interval landing. Just as in the takeoff, during element landings, the wingman maintains a modified parade formation position with Lead

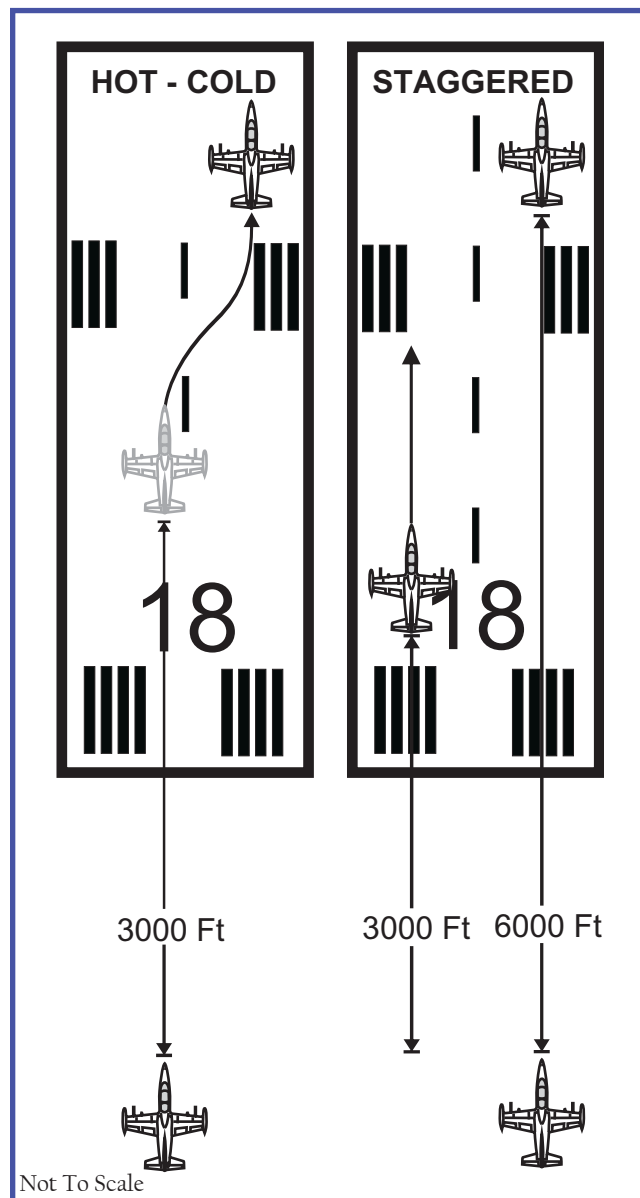

Figure 2.12 Hot-Cold and Staggered Landings: Jet

throughout the approach and touchdown. The element landing is generally executed from a straight in approach.

Interval landings on the other hand, are executed single ship, after the formation aircraft take spacing using the overhead or standard “rectangular” VFR pattern. This does not mean the aircraft are no longer flying in formation – they are very much still a flight and must remain visual, respect minimum distance criteria, and coordinate approach speeds to insure the recovery is efficient and safely executed.

#### 2.9.1 Interval Landing Options

The flight will use one of two interval landing options on runways adequately wide enough for formation recoveries; staggered or hot-cold (see figure 2.11 and 2.12). Both procedures require a runway wide enough to provide a comfortable margin for two aircraft to pass one another in the event of a brake failure or other aircraft malfunction.

### ● Staggered Landing Procedures

Using staggered landing procedures, the flight lead will land on the side of the runway that corresponds with the parking ramp exit, now termed the “cold” side. Number 2 will land on the opposite side and will transition to the cold side of the runway when braking action is confirmed, and safe closure/range to preceding/lead aircraft is assured.

When staggered landings are conducted in more than two ship formation, wingmen will land on alternate sides of the runway and those landing on the opposite of the parking ramp, now termed the “hot” side, will cross only when cleared to do so by the succeeding wingmen. This call should come automatically from the trailing aircraft when he/she has insured proper braking/deceleration. There is no requirement to *request* clearance to cross, unless the trailing aircraft fails to provide that clearance.

If performed in a timely manner with adequate interval between aircraft, this procedure should insure each aircraft has the required runway for deceleration. Used with improper interval, the staggered landing procedure may create a hazard due to inadequate runway for aircraft experiencing loss of brakes or other malfunctions.

#### WARNING

During Hot-Cold or Staggered landings, maintain minimum recommended landing interval to prevent an on-runway collision.

### ● Hot-Cold Landing Procedures

The standard multi-ship recovery procedure used by military Air Forces around the world, the flight lead will land on the side of the runway of intended exit to the parking ramp, thus again designating the “cold” side. All Wingmen however, will then land favoring the hot side of centerline and move to the cold side as soon as practical. Used with the recommended landing intervals in figure 2.11/12, this procedure should provide a clear lane for each arriving aircraft using the “hot” side for emergency roll out, low approach or go-around. During four ship, hot-cold landing procedures eliminate the need for wingmen to cross in front of landing aircraft or pre coordinate such actions over the radio.

Flight leads should clarify the desired procedure during the mission briefing. Regardless of procedure used, if landing interval is too short, such that both lanes of the runway are occupied with decelerating aircraft that could pose a potential collision hazard with loss of brakes or other malfunc-

tion — go around.

## 2.9.1 Traffic Pattern Recoveries

There are two types of formation traffic pattern recovery procedures available to the leader; the standard “rectangular” pattern or the “overhead” pattern. Due to the unfamiliarity with formation operations by the general aviation community, it is important to use disciplined radio and traffic pattern procedures in accordance with the Aeronautical Information Manual (AIM) or host nation equivalent when operating in and around towered or non towered airports.

### Lead

Before approaching the field, ensure you have the current Airport Terminal Information Service (ATIS) information provided at most towered airports or available equivalent (AWOS/ASOS) provided at many non-towered airports.

To enhance visual scanning while descending and approaching the pattern/airfield, it is advisable to move the wingman to route formation. Return to fingertip as required to execute the landing procedure desired (overhead, element landing, etc.)

If your destination is a tower controlled facility, contact the tower when approximately 15 miles out if able and request your desired formation recovery procedure. U.S. tower controllers are familiar with the overhead procedure, but you must be prepared to conform to a standard rectangular pattern if the maneuver can not be approved. For non-towered airports, make your initial position report with landing intentions approximately 10 miles from the field.

### Wingman

Regardless of the recovery option used, the wingman should try to remain aware of his/her position in relation to the airfield during the recovery. This will help anticipate Lead’s actions. When directed to switch to arrival frequency, move to route formation if not already directed by the Flight Lead. Once established in the pattern, all turns away from the wingman will be flown in echelon (reference section 2.8.3).

#### 2.9.1.1 The VFR Rectangular Pattern

If recovering to a standard VFR pattern, the formation should strive to use proper radio position calls in accordance with the Aeronautical Information Manual (AIM) or host country equivalent.

For non towered airports, make applicable position calls entering downwind, base and final. Make a final call when the last aircraft is leaving the runway.

##### 2.9.1.1.1 Take Spacing in the VFR Pattern

If landing single-ship, the Flight Lead may direct the flight to take spacing before entering the pattern, or by having the wingman delay the base turn to establish the desired spacing for landing, see figure 2.13. With this option, the Flight

Lead may call/signal for configuration in fingertip while on downwind using standard radio procedures or visual signals in accordance with Appendix A.

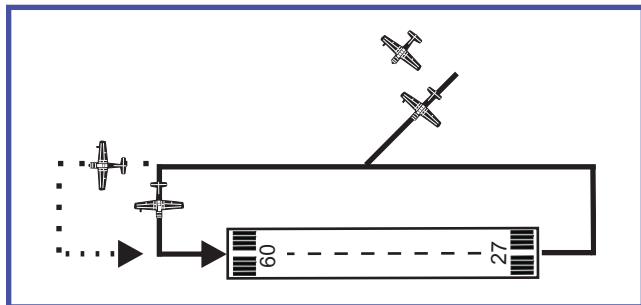

**Figure 2.13 VFR Pattern and Sequential Base Turn**

To communicate the desired base turn interval, Lead should provide the pitchout signal and indicate the number of seconds between aircraft. The wingman will then delay their base turn as directed. Recall minimum landing interval is based on runway width and interval landing procedure used. All overhead interval *landing considerations* in section 2.9.1.2 apply equally to the rectangular pattern.

At tower controlled airports, if desiring to land sequentially from the VFR pattern in which multiple flight aircraft will be on the runway simultaneously, lead should clarify his/her flight intentions with tower to preclude the wingman from being directed to go around under normal ATC procedures.

### 2.9.1.2 The Overhead Pattern

The 360° overhead pattern is an efficient way to rapidly recover the formation. The overhead pattern involves flying an upwind leg aligned with the landing runway at pattern altitude called “initial”, followed by a steep-bank “break” turn when over the runway. After a short downwind to allow for aircraft configuration, the aircraft reach the “perch” and commence the descending base turn to final, rolling out approximately 1/4 mile on final on a normal glide path for landing. This pattern allows you to bleed off airspeed in the turn to downwind for gear extension, and rapidly recovers all formation aircraft, see figure 2.14.

#### Lead

During the recovery to the initial point, see figure 2.14, place the wingman on the side opposite the direction of the break turn. If recovering to an uncontrolled field, listen for general aviation traffic reports to determine their effect on your recovery and adjust accordingly. Pay attention to forecasted/reported crosswinds and their effect on the overhead pattern; an undershooting wind at the break (turning in to the wind) will tighten your turn radius, which will be followed by an overshooting wind during the base turn. This combination, left uncorrected, can lead to excessively tight patterns from which a safe approach and landing may be impossible.

During the initial leg at pattern altitude, as you approach

#### WARNING

Failure to analyze crosswind effect on the overhead pattern, particularly overshooting winds during the base turn, may result in excessively tight patterns from which a safe approach and landing may be impossible.

the field, you will lose sight of the runway under the nose. Choose a drift-killed landmark on the horizon to maintain your desired track along the extension of runway centerline. The break point, often at the approach end of the runway, will likewise be invisible to you at altitude - use a lateral visual reference coinciding with the desired turn point. Before reaching the runway environment, provide the wingman the hand signal for the pitch-out. The default interval is 5 seconds between aircraft, which will provide the recommended minimum landing interval for staggered or hot cold procedures (1500 feet). If an alternate pitchout interval is desired, provide this information to the wingman by holding up the number of fingers corresponding to the seconds desired.

#### INSTRUCTORS' NOTE

During initial student training, use a 5 second pitchout interval. This will provide approximately the minimum recommended interval for landing with a common perch point

Over the approach end of the runway, or as required by the tower, traffic or wind conditions, initiate the break to downwind. Do not reduce power until after beginning the pitchout turn. Fly a level turn, using up to 60 degrees of bank to downwind, while slowing to the briefed traffic pattern airspeed. Your earlier wind analysis now comes in to play; if there is a significant crosswind being reported, adjust the pitchout accordingly. An undershooting wind at the break coupled with an aggressive pitchout may lead to an excessively tight pattern. Remember; you may be leading a less experienced formation student through the overhead pattern.

When rolling wings level, check for proper runway displacement and lower the landing gear and flaps as required by your aircraft's Pilot Operating Handbook (POH). Hold briefed approach speed to ensure formation interval is maintained. If the downwind leg is extended for any reason, such as a traffic conflict, pick up a drift killed landmark ahead to maintain desired track. Complete the before landing checklist.

The perch position is the point on downwind, at traffic pattern altitude, where lead begins the descending, base turn to landing. The perch is generally located abeam the approach end of the runway, and may be adjusted for winds or traffic conflicts. At the perch position, initiate a descending

base turn to land. Transmit “gear down” in accordance with section 2.9.1.2.3. Again, analyze the winds (undershoot/overshoot) and adjust bank angle accordingly to roll out on short final. Use a normal to slightly long aimpoint; avoid dragged-in (low) finals, as this will then be mirrored by your wingmen.

If at any time your aircraft experiences a directional control issue (blown tire, locked brake, brake fade/failure), immediately inform your flight over the radio to provide ample time for them to initiate a go-around.

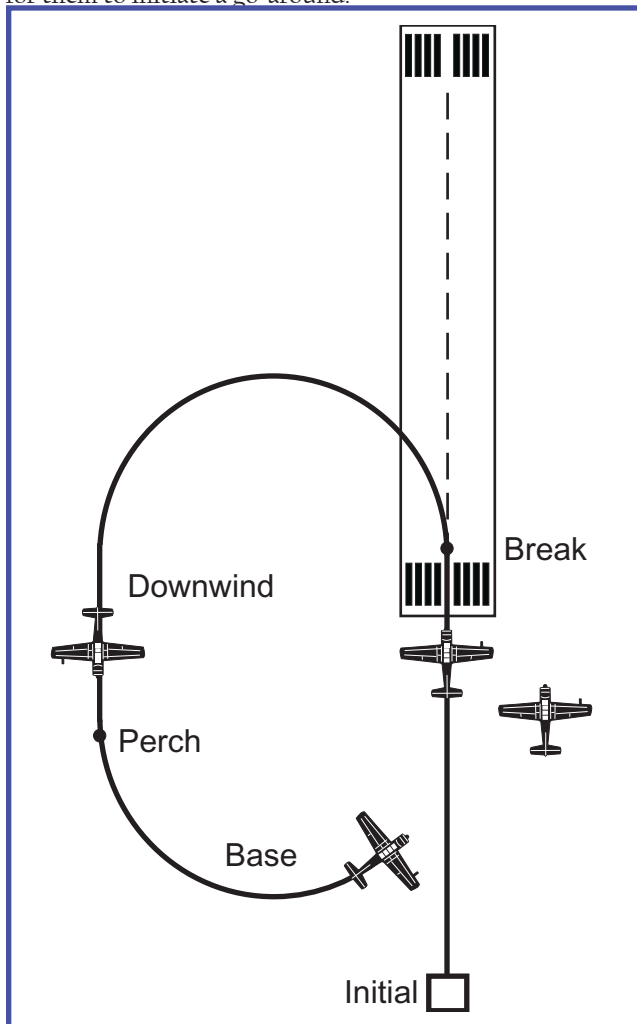

**Figure 2.14 Overhead Pattern**

### Wingman

After Lead breaks, delay for the briefed or signaled interval before initiating the break. Use 5 seconds if no guidance is provided, as this will insure you have the minimum spacing required for landing. Reduce power *after* the initial bank angle is set in the turn to downwind, and slow to the briefed traffic pattern speed while holding altitude level. Trim the aircraft as needed and keep up a rapid crosscheck to prevent getting slow. Roll out on the downwind behind Lead, slightly adjusting your flight path laterally or vertically to remain out of the preceding aircraft's wake turbulence.

Approaching the perch point, lower the landing gear and flaps, complete the before landing checklist, and cross-check the runway and lead to ensure proper spacing from both. When an expanded interval on number 1 is required (i.e. narrow runways requiring centerline roll out), delay the base turn accordingly. Never begin the base turn unless Lead is in sight.

After initiating the turn, fly your normal pattern at the briefed approach speed. Transmit a “gear down” with call sign and position number in accordance with 2.9.1.2.3. Maintain visual on Lead for proper spacing while cross-checking your altitude and airspeed during the near-continuous descending turn to final.

If landing on a 100 foot wide runway or greater, the use of staggered or hot-cold procedures should be used (see figure 2.11 and 2.12). For propeller aircraft with approach speeds under 100 knots such as the Yak 52 and Nanchang CJ-6, insure *no less than* 1500 feet (2000 feet desired) separation from the preceding aircraft crossing the threshold. This equates to no less than a 10 second interval between aircraft.

For jet aircraft such as the L-29 and L-39, with approach speeds in excess of 100 knots, use 3000 feet when landing staggered.

For all aircraft, if the runway width does not provide for two clear lanes with a minimum of ten feet of wingtip clearance, double the landing interval and use the full width (centerline) for landing and roll out as required.

If you have inadequate spacing on lead/preceding aircraft, or the runway becomes unsafe, simply execute a go-around. Clear to the left or right of landing aircraft, and when able fly a closed pattern or re-enter the VFR pattern as required. Never sacrifice the safety of you or your flight mates by reducing recommended safety parameters.



**Image 2.6 Landing From The Overhead In the CJ-6**

If landing staggered and lead/preceding aircraft has to cross to your side in order to clear the runway (crossing to the cold side), wait until you are assured your aircraft is under control before clearing the aircraft to cross.

“Raven 1 is cleared to cross”

If using centerline landing procedures on a runway wide enough for a hot/cold lane, when able and after confirming positive braking, all aircraft will move to the cold side as soon as it is safe to do so.

### WARNING

Always visually clear the lane if able before moving over, whether using staggered or hot-cold procedures.

Monitor lead/preceding aircraft to insure adequate spacing and closure during deceleration. This procedure will be critical when operating in larger formations as the “hot” side of the runway will be needed for aircraft experiencing brake failure, fade or other deceleration/emergency issues.

Regardless of the landing procedure used, taxi to Lead’s exit point. Do not change configuration (flaps) until clear of the runway.

#### 2.9.1.2.1 Tail Wheel Considerations

Tailwheel pilots must consider the restrictions to forward visibility when planning landing interval. Insure a free lane is available to decelerate with all wheels on the ground and adjust landing interval accordingly.

#### 2.9.1.2.2 Variations of the Common Overhead

Two common variations of the overhead are the pitchup break and fan break. Neither maneuver is an evaluated FAST item and should not be introduced to students unless under the supervision of a formation instructor.

- **Pitchup Break**

For the pitch-up break, lead will bring the aircraft up initial at less than pattern altitude (500 feet works well) and fly a climbing break, rolling out on downwind at pattern altitude. All other procedures remain the same.

- **Fan Break**

The fan break is performed solely for its visual appeal to onlookers/airshow attendees. Number one will execute a roll to 45 or 60 degrees for the break, insuring not to reduce power until after rolling, while using increasing positive G. Each aircraft will follow this roll near simultaneously in echelon but use sequentially less G to open up the interval between the preceding aircraft. This will result in the entire formation “fanning out” during the 180 turn to downwind.

#### 2.9.1.2.3 The Gear Down Call

All aircraft conducting formation flight training at RPA clinics should transmit a gear down call before crossing the landing threshold after positively checking their landing gear is down and locked, and brake pressure is nominal (pneumatic or hydraulic pressure). All formation flight members should transmit the following position and status call in sequence at towered and non-towered fields:

“Raven 1, Left Base, Gear Down, Full Stop”

“Raven 2, Left Base, Gear Down, Full Stop”

Because the gear down call is not required or expected at non-military airfields, insure the calls contain identical verbiage by all flight members. Although flight members transmit this call for mutual support and safety, identical radio calls reflect the professionalism of the flight to the general aviation community. Avoid the use of slang or individual verbiage during this call. Wingmen may be in a position to check the preceding aircraft’s gear as they initiate the base turn, but do not jeopardize aircraft control or flight path to do so.

### 2.9.2 Element Approach and Landing

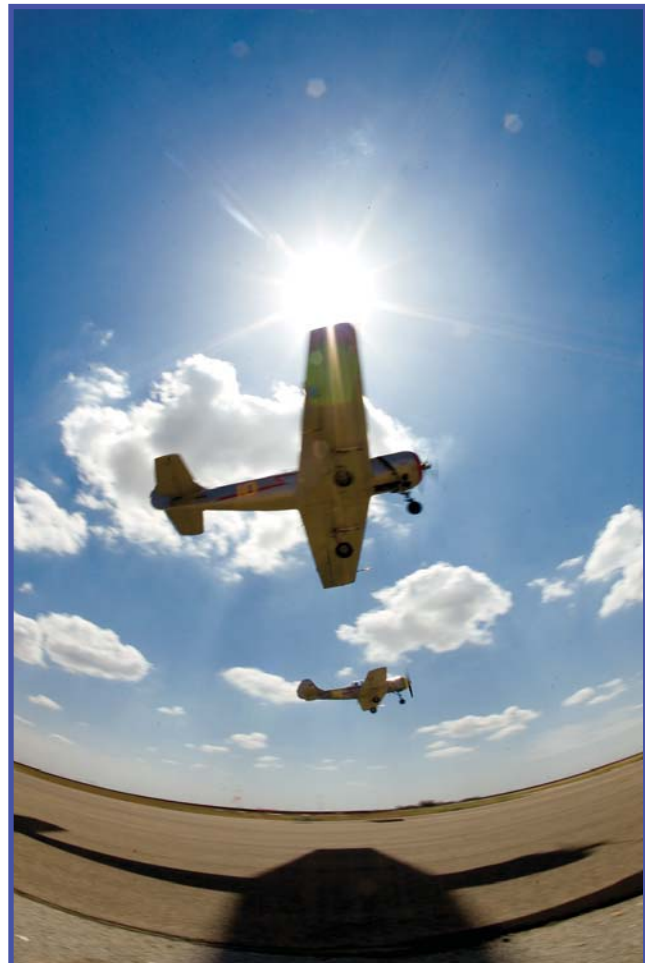

**Image 2.7 Element Landing In The Yak 52**

The element (formation) landing allows the efficient re-

covery of two aircraft simultaneously. Minimum runway width recommended for most RPA aircraft is 100 feet. At all airports, plan at least a 3 mile straight in approach when conducting formation landings for training, using a normal 3 degree glide path.

### Lead

At tower controlled airports, coordinate for a 3 to 5 mile straight in as desired and, if intending to practice an element go-around for training or evaluation, include the request for a “low approach” or “Option” in accordance with the AIM or host nation equivalent.

Slow to gear/flap extension speed and use a radio call or visual signals to configure the element for landing at or before initiating final descent. This will help insure a stabilized approach for your Wingman.

When flying a formation approach with some aircraft, you have the option of initially configuring the formation with partial or full flaps. If planning a formation landing and configured with partial flaps, lower full flaps upon intercepting the visual glide path. To avoid any confusion, brief the desired initial configuration during the preflight briefing.

Line up on the center of the appropriate side of the runway and establish an aim point that will allow a touchdown approximately 500 to 1,000 feet beyond the threshold. Plan to position the wingman to land on the upwind side of the runway when crosswinds are a factor, (e.g., greater than five-knot crosswind).

In the flare, make a smooth, slow power reduction to just above idle power. Use normal braking techniques and avoid early brake applications during element landings.

### WARNING

Element landings are not recommended when operating tailwheel aircraft. Use interval landing procedures to recover tailwheel aircraft in formation.

### Wingman

Strive to maintain situational awareness as the Flight Lead maneuvers to a 3 to 5 mile straight in. If using visual signals for configuration, when lead provides the preparatory signal for landing gear, insure any gear handle locks are removed and, if safe to do so, place your throttle hand on the gear handle in anticipation of the execution command (head nod). Repeat this procedure for lowering the flaps. This will help mitigate any sequential delays between aircraft and resultant drag changes.

Maintain the normal fingertip position until configured and approaching the normal descent point, then move up to stack level with Lead (Lead’s head superimposed on the

horizon) insuring a minimum of 10 feet of wingtip lateral spacing. This position approximates that used for formation takeoffs and is slightly acute of your normal bearing line position.

During the approach, the wingman should begin to acquire the runway with peripheral vision. Plan to land in approximately the center of your half of the runway with no less than 10 feet of wingtip clearance. Lateral spacing for the landing should allow adequate room if a problem occurs during touchdown or landing roll, but this spacing must not place you on/near the runway edge.

Lead is the primary reference for the wing landing. Cross-check the runway on short final to ensure proper alignment, then fly the proper position off Lead throughout the flare and touchdown. You should touch down slightly before or at the same time as Lead. After touchdown, maintain relative position on your side of the runway and use a normal braking technique, regardless of Lead’s deceleration rate. You should pass Lead rather than over-brake to maintain position.

If you touch down after Lead, it is likely that you will move ahead of Lead on the runway. If you overrun Lead, accept the overrun and maintain the appropriate side of the runway and aircraft control; do not engage hard braking to decelerate back in to position! This could result in a blown tire and directional control problems. The most important consideration is wingtip clearance.

If the element Lead must cross the runway center line to exit, you must ensure that you have safe spacing, safe speed and are under control before clearing Lead to cross in front of you.

## 2.10 The Go Around

During training, if the flight is planning to go-around or low approach from a formation recovery at towered airports, the Flight Lead should pre-coordinate this action by requesting a “low approach” or “option” as desired (AIM).

### 2.10.1 Go Around From The Overhead Pattern

There will be occasions when one or more members of a flight will have to go around after the pitch-out from the overhead pattern. Once the go around is executed, all go-around aircraft are considered single-ship, independent of the formation. The go-around aircraft will normally reenter the VFR traffic pattern. It is advisable to displace left or right from the runway to avoid overflying all landing aircraft ahead of you.

Insure proper radio procedures are used in accordance with the Aeronautical Information Manual (AIM) or host nation equivalent to avoid traffic conflicts/confusion with general aviation aircraft established or entering the pattern.

### 2.10.2 Go Around from the Element Approach

In the final stage of an element landing both aircraft are at low altitude, low airspeed, relatively high angle of attack and drag. Because of these factors, formation go arounds must be executed carefully and deliberately. Although element integrity is important, it is secondary to maintaining obstacle/ground clearance and safety of flight.

#### Lead

When confronted with a potential go around situation, the earlier the decision is made to execute the go around the easier it will be for the element to make the transition to stabilized, clean-configured flight.

When the decision has been made, announce your actions over the radio;

“Raven Flight is going around”

Simultaneously advance the throttle(s) smoothly to a suitable go-around power setting. Make allowances for a spare margin of power for your wingman. Do not attempt hand signals until the power is set and the flight is smoothly transitioned for a climb. When the flight is no longer descending, at a safe airspeed, call or signal for flaps up and raise the flaps. Once you have established a positive rate of climb for the flight, call or signal for gear up and raise the gear. Continue to climb and accelerate until you have achieved the desired altitude and airspeed.

#### WARNING

The element go-around is not a airshow maneuver - do not compromise aircraft control or delay critical steps to provide hand signals. Configure as needed in such cases. The wingman will configure based on your actions when safe to do so.

If instructed/required to displace to the left or right of the runway, confirm the position of your wingman. If your wingman cannot maintain formation position (slow/late power application, etc.) and slides aft, do not reduce power with the desire of aiding the wingman; he/she will fly a single-ship go around, configuring his/her aircraft visually with yours or as required for safety. Configure your aircraft as required. Once established at the desired altitude and airspeed, attempt to rejoin the flight or direct your wingman to continue single-ship.

#### WARNING

Do not initiate significant turns or call for the wingman to cross under below 400 feet unless absolutely required for safety. Improperly executed low altitude maneuvering may result in ground impact.

#### Wingman

When you hear Lead make the go-around call, anticipate a power increase to maintain your position in fingertip; the acute, stacked level position on approach is no longer required during the go around, but avoid any vertical maneuvering if the go around is initiated at low altitude.

If adequately climbing away and the flight lead uses radio calls or hand signals directing you to clean up the airplane—execute promptly on Lead’s command of execution to prevent falling out of formation position. However, in an actual go-around situation, lead may elect to fore-go visual signals for clean up (flaps and gear); be prepared to reconfigure visually with lead, *but only when safe to do so*. Always consider your airspeed, altitude and climb rate before changing configuration.

If you fall well behind or out of position during the transition to the climb profile, establish a slight “offset” trail position so as to avoid prop/jet wash and wing vortices while advancing throttles as needed to execute a safe go around. Maintain the offset trail position while keeping Lead in sight. If able, approach no closer than route formation until directed otherwise.

### 2.11 Taxi In and Shutdown

Once clear of the runway, Lead assembles the flight for taxi to the ramp. Flaps will be retracted on Lead’s signal or as briefed.

If parking together, the flight can shut down together. If conditions permit (i.e. no aircraft, people, or obstructions behind the formation), Lead will signal to perform the pre-shutdown run-up as required for your type of aircraft. Reduce power to idle and shut down on Lead’s signal.

### 2.12 Debrief and Summary

After everyone has a chance to secure his/her aircraft, the flight members assemble for the debrief. The goal of the debrief is to improve safety, performance, communication, and understanding. See Appendix C of this manual for guidelines on executing an efficient debrief! Two ship formation encompasses the majority of all formation maneuvers. We now move on to chapter three and the formation rejoin.

## CHAPTER THREE

### Two Ship Rejoins



**Image 3.1 A Yak 52 Comes Aboard**

### 3.1 Introduction

One of the most critical skills of every formation pilot is the execution of a safe and expeditious rejoin. Whether assembling after individual departures, or reforming on lead after an inadvertent breakout, sound rejoin skills will serve you well during every formation mission.

Unless otherwise noted, all concepts presented here are equally applicable to propeller and turbine powered aircraft. However, some supporting images may not reflect accurate visual references for your aircraft. Consult an experienced RPA Formation Instructor or Flight lead for further guidance.

#### INSTRUCTOR NOTE

When teaching formation rejoins, consult the Fluid Maneuvering Exercises contained in chapter four. The use of in-flight training exercises such as Offset Trail may assist your student's mastery of the concepts presented here.

### 3.2 Concepts and Terminology

The following are several concepts and terms that are critical to understanding the formation rejoin.

#### 3.2.1 Three-Nine Line (3/9 Line)

An extension of the aircraft's lateral axis. The wingman must remain aft of lead's 3/9 line during all formation flying unless specifically assigned the lead or number 1 position. (figure 3.1)

#### 3.2.2 Aspect Angle (AA)

Angle between lead's longitudinal axis and the line-of-sight to the wingman. The angle is measured from lead's six o'clock to the Wing's position. The wingman's heading is irrelevant. Aspect angle values range from 0° to 180°. A wingman at lead's six o'clock position would be at 0° AA, at lead's three or nine o'clock the wingman would be at 90° AA, and if the wingman is directly off lead's nose, the AA would be 180°. (figure 3.3)

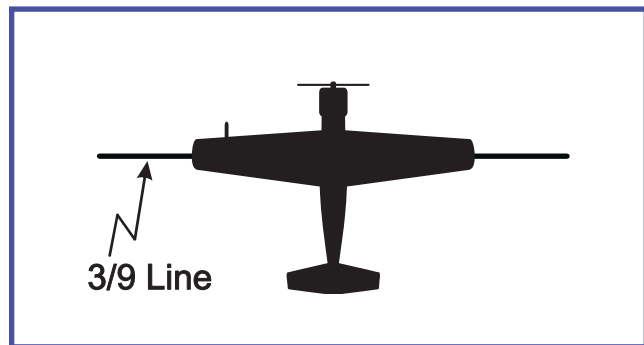

**Figure 3.1 The 3/9 Line**

#### 3.2.3 Heading Crossing Angle/Angle Off

Heading Crossing Angle (HCA) is the relative nose position of two aircraft. The angular distance between the longitudinal axis of the wingman and the longitudinal axis of the leader. This concept is dependant on the aircraft's heading. HCA is also known as *Angle Off*. (figure 3.3)

#### 3.2.4 Turn Circle

The circular flight path created by a maneuvering aircraft. The size of the Turn Circle is often measured in reference to the aircraft's turn radius, which will change with veloc-



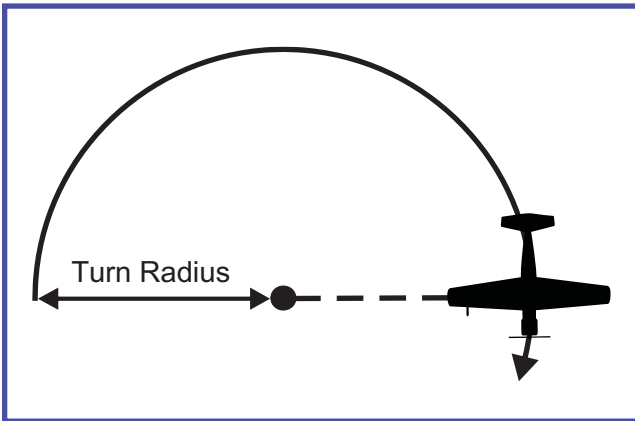

**Figure 3.2 Aircraft Turn Circle and Turn Radius**

ity, bank angle and/or load factor. To rejoin successfully, the wingman must be capable of maneuvering inside lead's turn circle. (figure 3.2)

**3.2.5 Turn Radius (Tr)**

The distance between an aircraft's flight path and the center of the turn circle. An aircraft traveling at 110 KTAS using 30 degrees of bank and 1.2 Gs, will produce a turn radius of approximately 1850 feet. (figure 3.2)

**3.2.6 Turn Rate**

Rate of change in heading, normally expressed in degrees per second. As the rate of turn is increased through an increase in angle of bank and/or load factor (G), the turn radius, and thus the aircraft's turn circle, decrease.

**3.2.7 Plane of Motion (POM)**

An imaginary plane defined by an aircraft's *actual* flight path through the sky. Based on bank angle and load factor (G), an aircraft's POM may be horizontal, vertical or any degree in-between. Reference figure 3.5 for an aircraft at 60 degrees of bank and 2.0 G, resulting in a level POM. Figure 3.4

**3.2.8 In-Plane**

When a wingman orients his/her turn circle in the same

plane of motion as lead, he/she is in-plane. Recall echelon turns from chapter two as a familiar example of two aircraft maneuvering in the same plane or, "in-plane". If the wing-

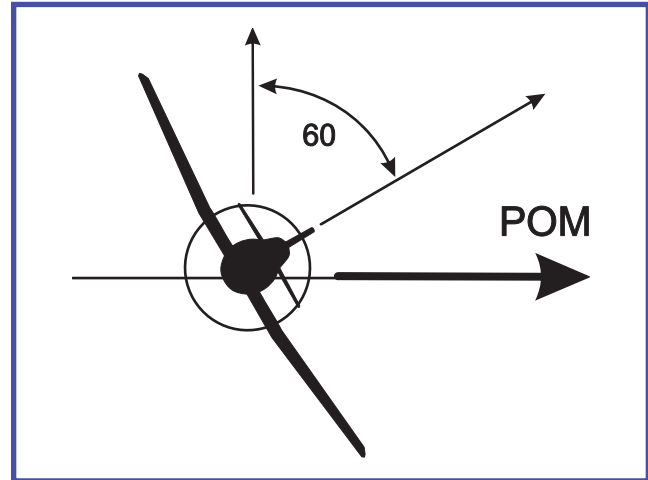

**Figure 3.4 Plane Of Motion (POM)**

man is not maneuvering in the same plane as lead, the pilot is "out-of-plane." All basic formation rejoins are performed level and in-plane (i.e no vertical maneuvering required).

**3.2.9 Line of Sight (LOS)**

A line from the pilot's eye to the object the pilot is viewing, such as the other aircraft in formation.

**3.2.10 Line of Sight (LOS) Rate**

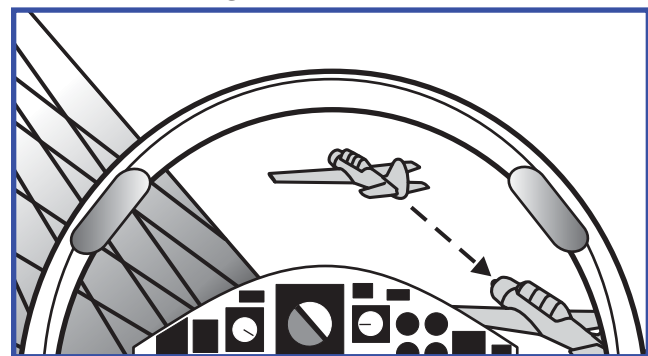

**Figure 3.5 Positive Closure Creates Aft Los Rate**

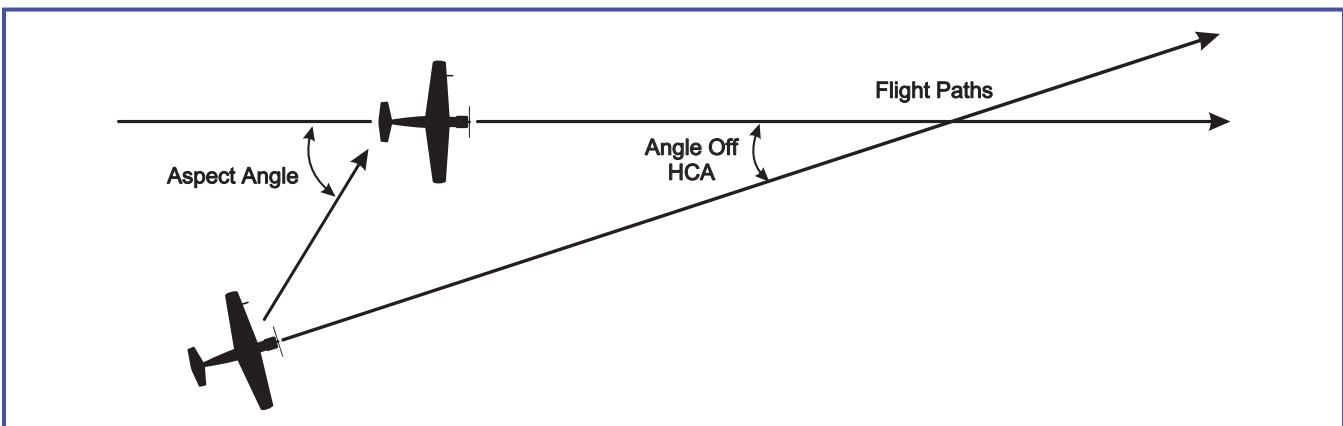

**Figure 3.3 Aspect Angle and Angle Off**

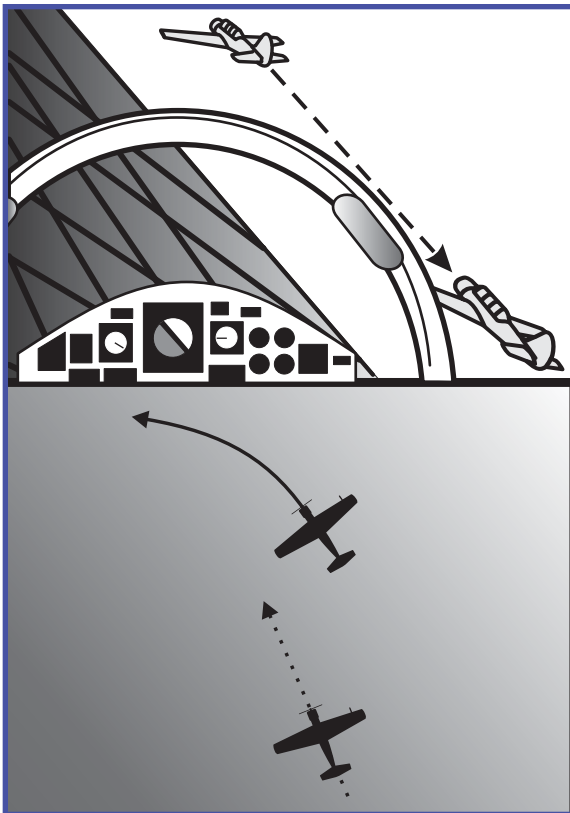

Figure 3.6 Lead Pursuit and Aft LOS Rate

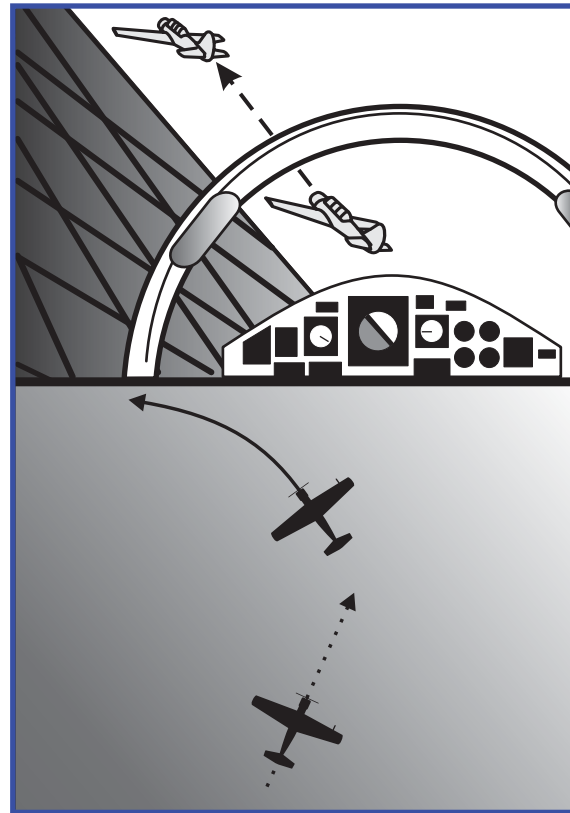

Figure 3.8 Lag Pursuit and Forward LOS Rate

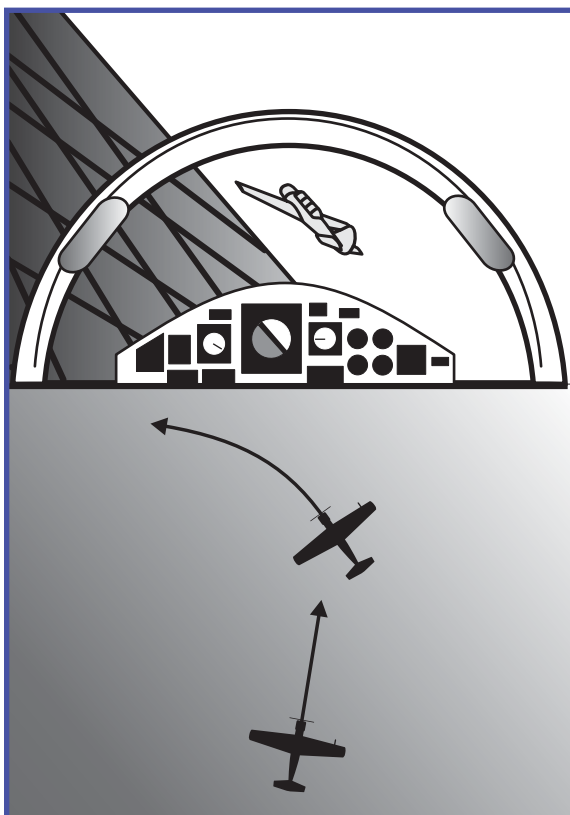

Figure 3.7 Pure Pursuit Picture

The rate of movement of an object, such as another aircraft, across the canopy. When overtaking another aircraft through lead pursuit and/or airspeed advantage, an aft LOS rate will be observed. Likewise, if falling behind due to lag pursuit or airspeed disadvantage, a forward LOS rate will be observed. The LOS rate provides a valuable clue to the wingman in recognizing and controlling closure during the rejoin (figure 3.5, 3.6, 3.7, 3.8).

### 3.2.11 Pure Pursuit

The path a wingman's aircraft will follow if he/she flies directly at the lead aircraft. Lead's aircraft will remain stationary in your canopy (no LOS rate). Note that in pure pursuit, heading crossing angle equals aspect angle. (figure 3.7)

### 3.2.12 Lead Pursuit

The flight path a wingman's aircraft will follow if he/she flies toward an imaginary point in front of the lead aircraft. This results in a situation where the wingman is "cutting off" lead. Uncorrected, lead pursuit will result in the wingman moving in front of the lead aircraft. During maneuvering (turning), pulling lead pursuit results in the wingman flying a smaller turn circle than lead, and thereby closing the interval, or creating closure, with lead. You can modulate the effect of your lead pursuit by choosing an aim point nearer or farther away from lead's nose—nearer resulting in a less aggressive cut off. When you initiate a lead pursuit curve there will be distinct visual cues to include an aft LOS rate and increasing aspect angle. (figure 3.6)

### 3.2.13 Lag Pursuit

The path a wingman’s aircraft will follow if he/she flies toward an imaginary point aft of the lead aircraft. Left uncorrected, lag pursuit will result in the wingman flying aft of the lead aircraft. During maneuvering flight, lag pursuit is achieved when the wingman’s nose position and flight path are on an arc outside of the curve flown by lead. This results in a situation where the wingman is flying a larger circle than lead and is thereby increasing the interval with lead. In lag pursuit the visual cues will be forward LOS rate, decreasing aspect angle and increasing heading crossing angle. Lag can also be modulated—an aim point farther aft of lead’s tail will result in more accelerated separation. (figure 3.7)

### 3.2.14 Closure ( $V_c$ )

The rate of change in the range between two aircraft.  $V_c$  (pronounced V sub c) can be either positive or negative. Positive closure will occur if the wingman has excessive speed or is flying lead pursuit, and is magnified if he/she is doing both. Negative closure will occur if the wingman has lesser airspeed or is flying lag pursuit, and is also magnified if he/she is doing both. The term “overtake” is used in this manual to reflect closure based on an airspeed advantage between the lead or wingman.

Pursuit Curve	Aspect Angle:	HCA:	Closure:	LOS Rate:
Lead:	Increasing	Decreasing	Increasing	Aft
Lag:	Decreasing	Increasing	Decreasing	Forward
Pure:	N/A	N/A	Increasing	N/A

**Table 3.1 Pursuit Curve Relationship Chart**

## 3.3 Formation Rejoins

Using the concepts presented in section 3.2, the proficient wingman is capable of safely and expeditiously closing with another aircraft to regain the parade formation position. The rejoin is the mark of an accomplished formation pilot. A rejoin is performed as either a turning (sect. 3.3.3) or straight ahead maneuver (sect. 3.3.4).

Basic rejoin training will be conducted from a trail position using either the pitchout or take spacing maneuver (covered below).

### 3.3.1 Pitchout

The pitchout, introduced in chapter 2 in the overhead recovery, is also used to create in-trail spacing for fluid maneuvering exercises (chapter 4) and rejoin training (figure 3.9).

#### Lead

Signal number 2 for the pitchout using an index finger pointing skyward, in a rotating motion. Unless the interval has been previously briefed, immediately hold up the number of fingers to indicate the desired interval between aircraft in seconds, generally 3 to 7 seconds (for a more thorough discussion on selecting rejoin interval, see “Turn Circle Geom-

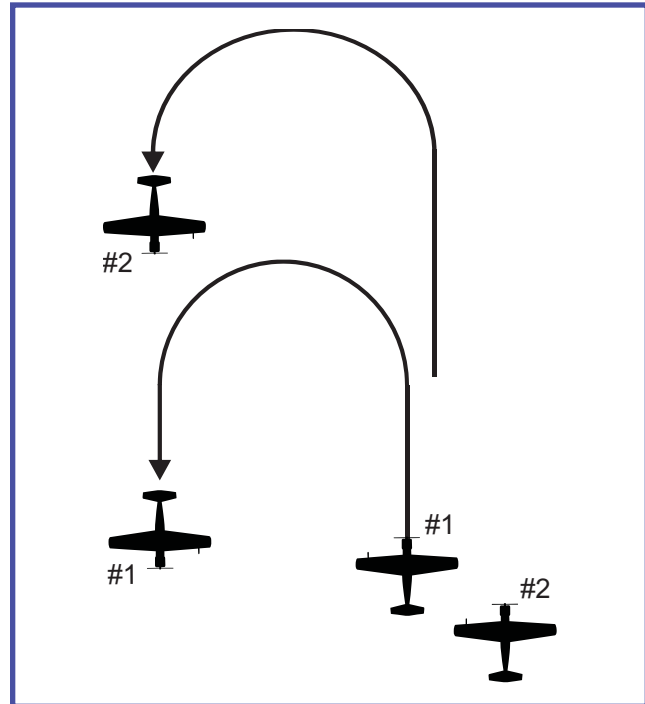

**Figure 3.9 The Pitchout to Trail**

etry”, Section 3.7). With acknowledgment from the wingman, clear carefully in the desired direction and begin a turn away from number 2, using 45° to 60° of bank and sufficient G to establish/maintain the desired airspeed. Fly a level turn unless slight climbs or descents are needed for energy. Roll out after approximately 180 degrees of turn or as needed for airspace orientation. Insure power is set to maintain briefed rejoin airspeed as required.

#### Wingman

Acknowledge the pitchout signal with a head nod. As soon as lead turns away, clear ahead, then in the direction of turn. With the preceding aircraft in sight, wait the specified interval, and make a matching turn, clearing carefully for traffic. After initiating the pitchout, set power to achieve and maintain briefed rejoin airspeed as needed.

Approaching the rollout, modulate bank and back pressure to fall directly behind lead with lead on the horizon. This is an excellent opportunity to make a quick scan of the instruments and fuel to ensure all is well. Call in when level and stabilized behind lead, “Raven 2’s in”.

### 3.3.2 Take Spacing Maneuver

The take spacing maneuver is an *alternate* method used to put number two in trail when a pitchout is not practical or desired. While the pitchout is universally applicable to both two ship and four ship training, the following maneuver is limited to two ship only. There are no hand or aircraft signals for initiating the take spacing maneuver.

#### Lead

Direct number 2 to take spacing with a radio call, “Raven 2,

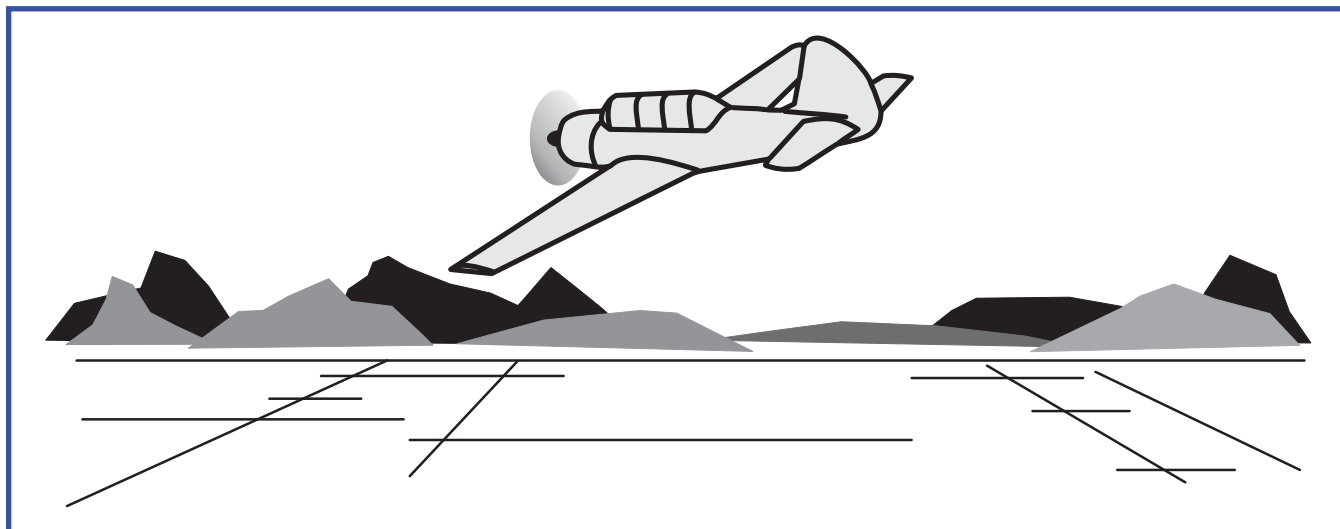

**Figure 3.10 Rejoin Sight Picture**

take spacing”. After the wingman acknowledges with call sign, lead may accelerate, if able, to expedite the maneuver. If an interval and airspeed were not briefed for the maneuver to follow, or a specific interval is desired, provide this information in the initial radio call. When number 2 calls in position, reset power and commence maneuvering.

#### **Wingman**

Acknowledge lead’s instruction to take spacing with full call sign, reduce power and/or use speed brakes to move aft. Once clear of lead, you may use s-turns behind and below lead’s prop/jet wash to expedite the maneuver, using caution to keep lead in sight. When approaching the pre-briefed in-trail interval, set power to avoid sliding farther aft and call “Raven 2’s in.”

#### **INSTRUCTOR NOTE**

During training, both student and instructor in the wingman’s aircraft must be capable of maintaining visual with lead’s aircraft at all times.

### **3.3.3 Turning Rejoin**

Turning rejoins may be required due to breakouts, practice lost wingman, lost sight situations, interval departures (chapter two) and to rejoin the flight after terminating Fluid Maneuvering Exercises (chapter four). During two ship formation, number 2 always rejoins to the inside of the turn

unless briefed or cleared by the flight lead.

#### **Lead**

With the pitchout complete and the wingman having called in position, initiate the rejoin with a wing rock in the desired turn direction using up to 60° of bank. Then establish a level, 30° bank turn for training. If rejoin airspeed has not been briefed, or if you are not within 10 knots (10% for high-performance props and jets) of the briefed rejoin airspeed, make a radio call announcing the airspeed. Hold speed, altitude and bank angle constant throughout the rejoin.

Monitor the rejoin, dividing your attention between clearing for the flight, maintaining a stable platform, and analyzing the wingman’s altitude, aspect, and closure. If you perceive an unsafe situation developing at anytime, take positive action immediately to prevent a midair collision.

#### **Wingman**

When lead enters his/her rejoin turn, begin a turn in the same direction, pulling lead pursuit to intercept a moderate aspect angle as depicted in figure 3.11. Use power to gain an airspeed/closure advantage. Normally 10% above briefed rejoin airspeed is adequate.

Set approximately 10-20 feet of vertical step down. As a technique, keep lead’s lower wingtip on or near the horizon (for most low wing aircraft).

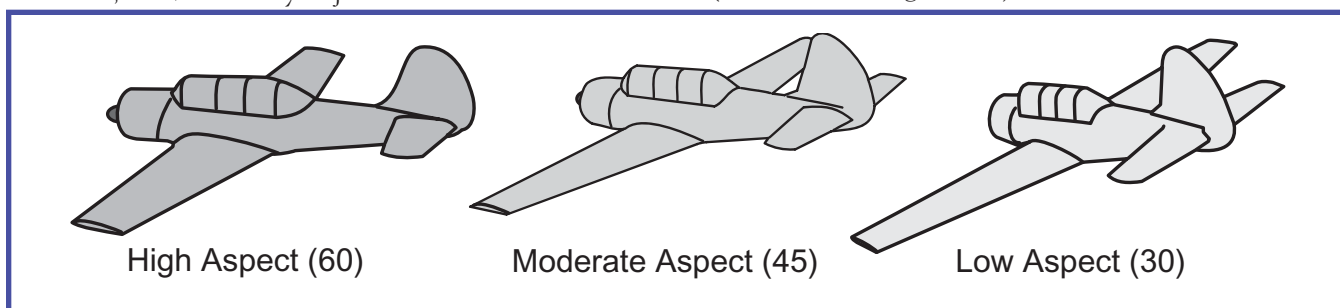

**Figure 3.11 Visual Recognition of Changing Aspect**

Referencing Figure 3.11, notice how the relationship of the vertical stabilizer and the outboard wing changes in the three depictions between high aspect, moderate (desired), and low aspect. These visual references approximate 60°, 45° and 30° AA respectively.

If lead's vertical stabilizer moves toward the wing root during the rejoin, aspect angle is decreasing and closure decreases, thus slowing the rejoin process. Alternatively, if the vertical stabilizer moves aft of the outboard wing tip, aspect angle is increasing and closure is increasing. Excessive closure will complicate the rejoin process and possibly lead to an overshoot (covered later).

Aspect angle is controlled by changing your pursuit curve (lead/lag) in relation to lead. Vary your pursuit curve with bank angle. Shallow your bank (less lead pursuit) to decrease aspect angle and increase the bank angle (more lead pursuit) to increase aspect angle.

#### CAUTION

Avoid too much lead pursuit early in the rejoin (excessive aspect) because the correction for excessive aspect is often an equally large correction to lag pursuit. Performed too late, this correction will result in excessive heading crossing angle in close proximity to lead and a possible overshoot or breakout situation.

During the initial turn to establish lead pursuit, as lead's vertical stab approaches the wingtip (moderate aspect), reduce bank to capture this visual reference, and then employ small adjustments to bank angle to maintain this as you close on lead. In a proper rejoin, HCA/Angle Off is low and there is no LOS rate as range decreases between wingman and lead. Lead should appear slightly above the horizon throughout the rejoin. Avoid the common tendency to descend during the rejoin. This will complicate your approach and slow the rejoin.

The critical stage of the rejoin begins approximately at 500

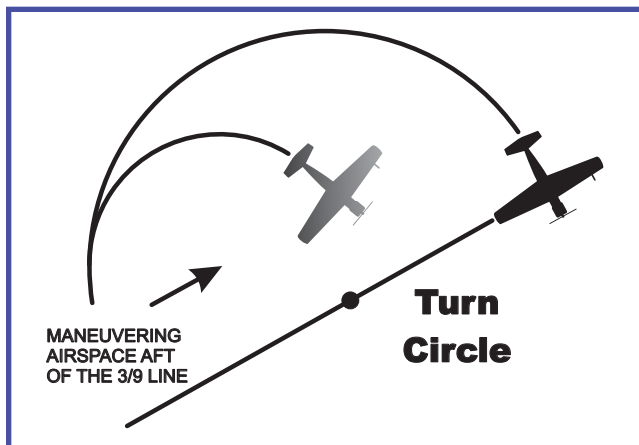

Figure 3.12 Maneuvering Airspace During Rejoins

feet from Number 1. Inside 300-500 feet, the normal fingertip references will become visible. Begin decreasing closure with a power reduction and/or speed brake, as necessary. As range decreases inside approximately 100-200 feet (route spacing), the vertical stabilizer will appear to move aft of the outside wingtip as the aircraft grows in your canopy. With nearly co-air speed and aligned fuselages (no angle off), there should be no LOS rate in your canopy.

Monitor bank and overtake closely during the last few hundred feet to ensure aspect and closure are under control. Plan to stabilize in route (2-4 ship widths) with slight positive closure, but approximately co-air speed with number 1 and then move into fingertip at a controlled rate.

Approaching route interval, the following are some indicators of a successful, and safe, rejoin:

- Your fuselage and bank angle are nearly aligned with lead's and the LOS rate is near zero (no fore/aft movement on the canopy).
- You are slightly below lead with moderate aspect.
- Your closure is slightly positive with airspeed matching lead's.
- Your closure is such that you could stop the rejoin in route, as required.
- For turning rejoins from 5 seconds in trail, the goal is for number 2 to be joined up within 180° of turn.

If rejoining to the outside of the turn, pass below and at least one ship-length behind lead. Maintain enough positive closure (about 10-15 knots) to facilitate this move to the outside. Stabilize in route echelon on the outside and then move into close (fingertip) at a controlled rate - rejoin complete!

#### CAUTION

For turbine powered aircraft equipped with speed brakes, to control closure with power, use the speed brake after the power has been reduced (generally to no less than 80-85% rpm). This results in less spool up time required, critical with aircraft that experience excessive lag between increased power selection and actual power delivery.

#### 3.3.4.1 Turn Radius Charts

The following turn radius charts are no wind approximations for aircraft operating at typical airspeeds and altitudes for both radial and turbine aircraft. They provide a perspective of the size of the turn circle in relation to pitchout interval. As mentioned, the size of the turn circle is based on bank angle, load factor and true airspeed. To calculate your

Figure 3.13 Misaligned Turn Circles Geometry Exercise

**INSTRUCTOR NOTE**  
Reference chapter four, Fluid Maneuvering, for additional in-flight exercises.

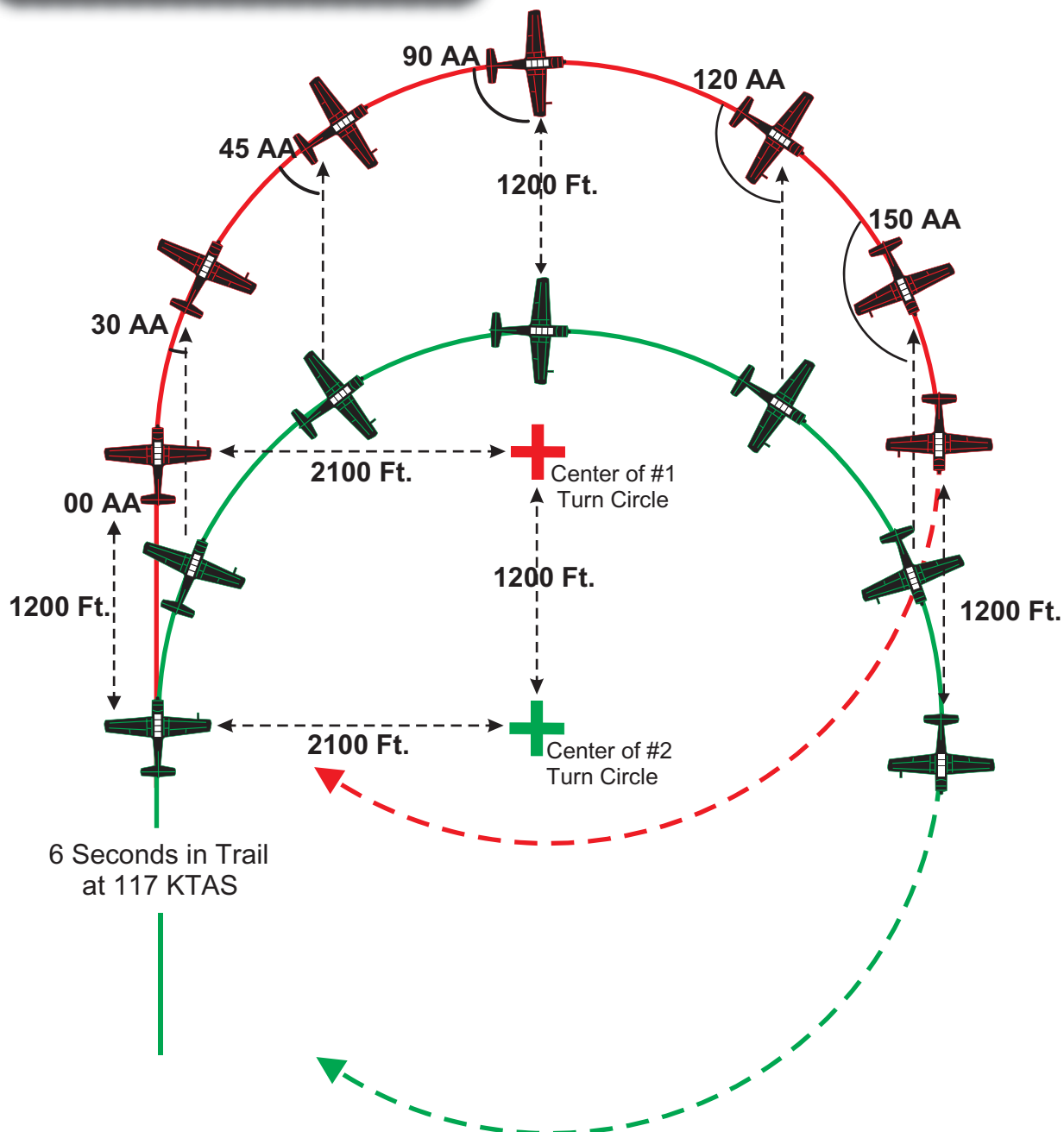

In this example, trailing 6 seconds at 110 KIAS/117 KTAS at 3000 feet msl, number 2 will be approximately 1200 feet in trail with number 1 and within lead's turn radius. Both aircraft should simultaneously establish a 30° bank turn in the specified direction, each generating turn circles with a turn radius ( $T_r$ ) of just over 2100 feet. Pilots in both aircraft should note how closure, range, and angle off/HCA remain constant, while the wingman will observe an aft LOS rate as his/her nose continues to generate more lead pursuit and increasing aspect purely through the geometry of misaligned turn circles. To correct aspect, number two will have to reduce bank angle (lag) as required to prevent a 3-9 overshoot as depicted in figure 3.17.

approximate true airspeed for any altitude, use an average increase of 2% of indicated airspeed per thousand feet of altitude; although not exact, it will be close enough for planning purposes.

Speed: 110 KIAS / 117 KTAS Altitude: 3000 MSL TR: 2100 feet	
Pitchout Interval:	In-Trail Distance At Roll Out:
3 Seconds	1200 Feet
5 Seconds	1950 Feet
7 Seconds	3300 Feet
Turn Radius Calculated at 30 Degrees AOB and 1.2 G	

**Table 3.2 Interval vs. Turn Radius at 110 KIAS**

Speed: 220 KIAS / 264 KTAS Altitude: 10000 MSL TR: 7500 feet	
Pitchout Interval:	In-Trail Distance At Roll Out:
3 Seconds	2600 Feet
5 Seconds	4400 Feet
7 Seconds	6200 Feet
Turn Radius Calculated at 30 Degrees AOB and 1.2 G	

**Table 3.3 Interval vs. Turn Radius at 220 KIAS**

Due to the geometry of the 180 degree turn, a 5 second pitchout will result in approximately a 10 second in-trail interval. In other words, pitchout interval nearly doubles the resultant in-trail interval. As demonstrated in Table 3.2 above, for the typical operating regime of the Yakovlev and Nanchang aircraft, a 5 second pitchout interval would place the wingman at/near lead's turn circle (approximately within lead's turn radius, see figure 3.14). This is not the case for the higher airspeeds and altitudes commonly utilized by turbine aircraft in the RPA, as reflected in Table 3.3. There is no requirement for a set in-trail interval when practicing turning rejoins, this information is provided for reference only!

**3.3.4 Mastering Turn Circle Geometry**

To successfully rejoin, you must position your aircraft inside lead's turn circle and aft of his/her 3/9 line (see figure 3.12). Because of this, one of the first things the wingman must determine at the start of a rejoin is his/her position relative to lead's turn circle. This analysis will be critical as you progress to rejoining from the number 4 flight position where intervals between wingman and lead can be significant.

As you can see, there are two turn circles to consider in a turning rejoin—the lead pilot's and the wingman's (see figure 3.14 or 3.15). While the lead's turn circle will be near static as he/she strives to maintain a constant airspeed, bank angle and load factor during the rejoin, the wingman has total control over both the size and location of theirs.

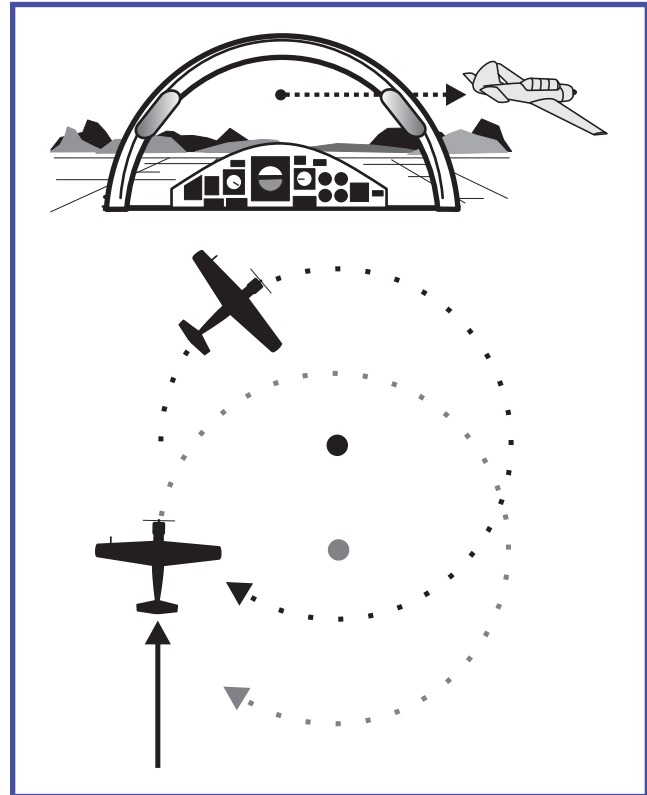

**Figure 3.14 LOS Rate Inside Lead's Turn Circle**

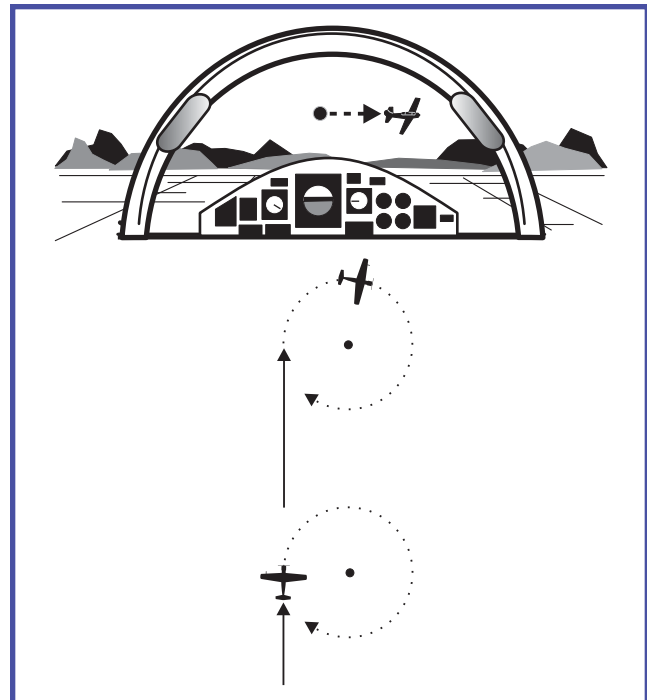
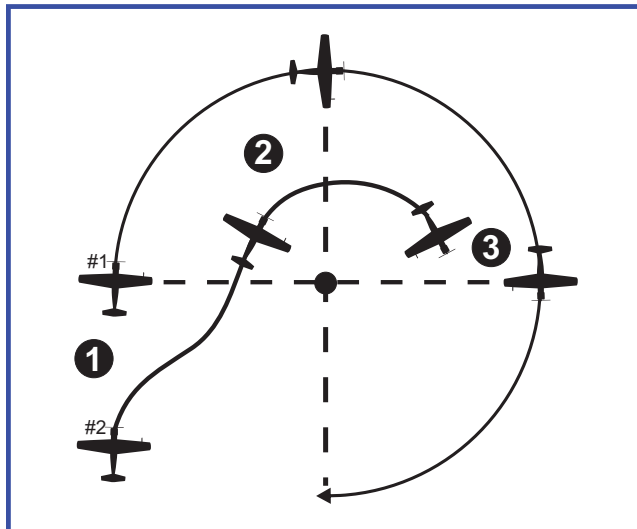

**Figure 3.15 LOS Rate Outside Lead's Turn Circle**

The size is determined by aircraft velocity, bank angle, and load factor, while the location is established at the initiation of the wingman's turn.

**3.3.4.2 Estimating Range to Lead's Turn Circle**

There are distinct visual references the wingman can use to assist in judging relative position to lead's turn circle.



**Figure 3.16 Lagging in to the Turn Circle**

In general, when inside of lead's turn circle, lead's rejoin turn results in a relatively moderate increasing aspect angle change, but a rapidly increasing LOS rate moving across your canopy. Reference figure 3.14. This phenomenon is due to the close proximity and the relative motion of the two aircraft.

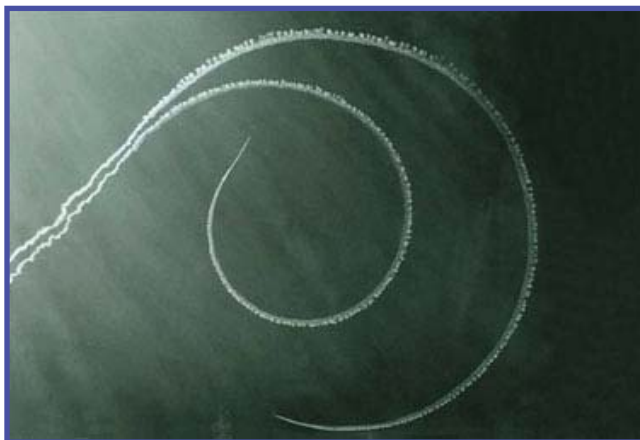

**Figure 3.17 F-16 Maneuvering Inside F-4 Turn Circle**

In comparison, if number 2 is outside lead's turn circle, he/she will see lead's aspect angle increase rapidly, but with minimal canopy LOS rate, primarily confined near the center of the windscreen as depicted in figure 3.15. The degree of this visual reference is based largely on your distance from the lead aircraft; farther away and the effect of rapidly changing aspect and minimal LOS rate is amplified.

If outside lead's turn circle, the wingman should continue straight ahead and accelerate as required. As number 2 closes on lead's turn circle, he/she will see the increase in lead's aspect angle begin to stabilize and the LOS rate begin to rapidly increase. At that point, the wingman is in position to maneuver for the proper aspect angle/visual reference for the rejoin. Often, as depicted in figure 3.17 above, this initial lead turn will follow with a moderate lag maneuver to enter the turn circle, aft of lead's 3-9 line.

In summary, to rejoin on another aircraft, you must maneuver within their turn circle and aft of the 3/9 line. As a visual reference, if lead's turn results in an increasing aspect angle and a relatively slow LOS rate confined near the center of the windscreen, the wingman knows the range may be outside of lead's turn circle and an immediate lead turn would result in excessive aspect and possible 3/9 line overshoot. However, if lead's turn results in a relatively moderate aspect angle change and a rapidly increasing aft LOS rate across the canopy, the wingman knows he/she is on or inside lead's turn circle. Use varying degrees of lead and lag to position your aircraft at the desired aspect angle.

### 3.3.5 Turning Rejoin Overshoot

The purpose of an overshoot is to safely correct overtake due to excessive airspeed, aspect and/or angle off. If the situation warrants, there is nothing wrong with overshooting and you should not delay or hesitate, reference figure 3.18.

#### Lead

During an overshoot, provide a stable platform for the wingman. However, if safety is a factor, take positive action to prevent a midair collision.

#### Wingman

An overshoot may be caused by excessive closure, excessive aspect angle, large heading crossing angle, or a combination of these factors. The overshoot is not uncommon in training and should not come as a surprise at the end of the rejoin, but should be a planned event based on timely recognition of excessive closure. There are several definitive clues leading up to an overshoot situation:

- Rapid closure, unaffected by idle power and/or speed brakes.
- Excessive HCA/Angle Off in close proximity to lead.
- Recognition for the need to significantly increase bank angle and/or "G" in close proximity to lead to salvage the rejoin. Termed "going belly up".
- Recognition of an uncomfortably rate of closure; an exponentially growing feeling of panic.
- lead directs an overshoot.

If you experience any of the above conditions, you will have to execute an overshoot. Take the following action:

- Abandon the rejoin no later than route position. (the rejoin must be stabilized by route position)
- Call the overshoot on the radio.
- Level the wings while keeping lead in sight—pass below and behind lead with at least two ship-lengths nose-to-tail separation.
- Continue to the outside of lead's turn circle but remain behind the 3/9 line and no higher than the echelon position.
- Move back inside of lead's turn, being careful not



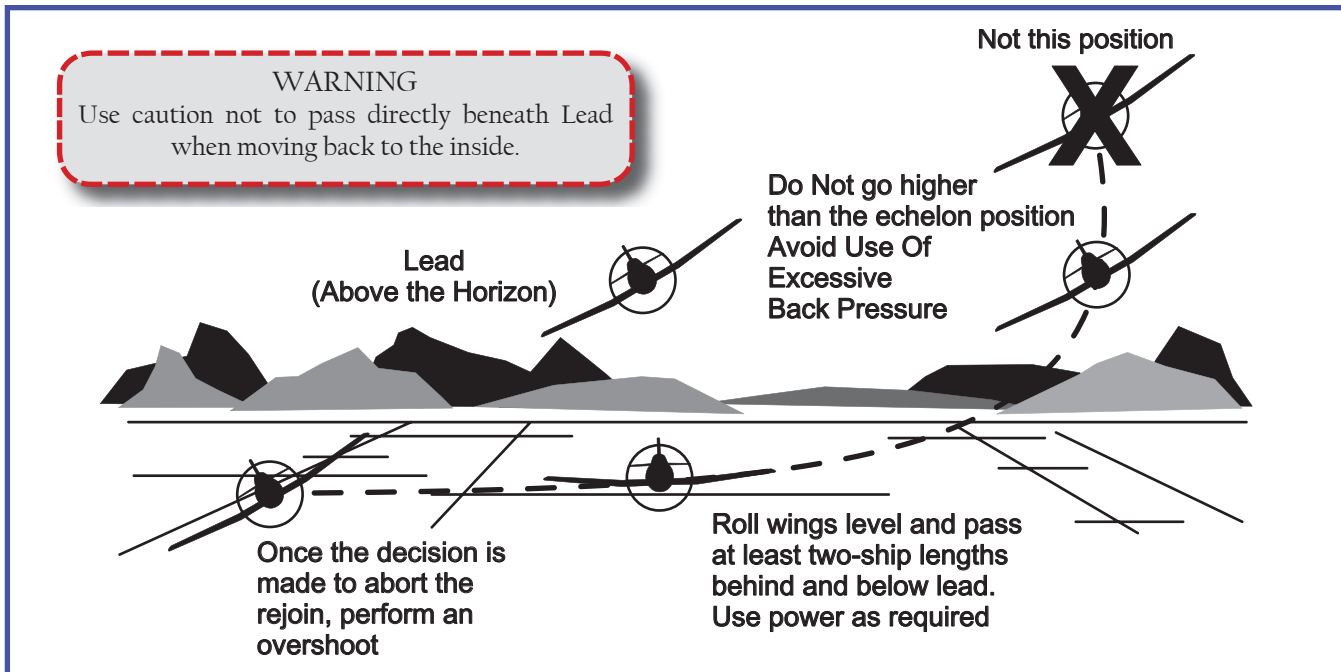

**Figure 3.18 Overshoot**

to pass under lead during the execution of this maneuver.

The greater your overtake (excessive airspeed) when executing the overshoot, the wider to the outside you must go to prevent moving forward of lead's 3/9 line. If you are outside lead, in route position, you can complete the rejoin by executing a normal cross-under. If you are outside and well aft of lead, you should cross back to the inside of the turn, reacquire the normal turning rejoin references, and complete the rejoin. Your instructor will demo the overshoot and allow you to practice this critical maneuver (figure 3.18).

### 3.3.6 Straight-Ahead Rejoins

#### Lead

Make a radio call or rock your wings to initiate a straight-ahead rejoin. Set power to maintain the briefed rejoin airspeed or call the rejoin airspeed on the radio if not within 10 knots of the briefed speed.

Monitor the rejoin, dividing your attention between clearing for the flight, maintaining a stable platform, and analyzing the wingman's altitude, aspect, and closure. If you must turn after initiating the straight-ahead rejoin, announce this to number 2 and be alert for an overshoot situation.

#### Wingman

Rejoin to the left side unless briefed otherwise. Set the power to establish the same minimum closure as in a turning rejoin (recommend 10% above briefed rejoin airspeed). When initiating the rejoin from beyond 500 feet aft, establish pure pursuit at lead's low, six o'clock position. Remain slightly below lead (lead on or just above the horizon) at all times to avoid lead's wake turbulence.

When you have closed to approximately 500 feet, aircraft details will become visible—bank slightly away from lead to establish an offset, two to four ship-widths out from lead's wingtip (the route position). This offset will give you an oblique view of lead, making depth perception and closure easier to judge. Decrease overtake with a power reduction and/or speed brakes and plan to arrive in route position at the same airspeed as lead. If your rejoin is stabilized, move into the fingertip position.

As a technique to avoid large and excessive throttle movements as you close in during the rejoin, reduce power in proportion to lead's LOS rate such that a slow LOS rate will result in a gradual power reduction while a fast LOS rate will result in a rapid power reduction. It will take some practice to learn your aircraft's deceleration rate.

If your closure rate is excessive during a straight-ahead rejoin, reduce power to idle and use speed brakes as necessary to slow your overtake. Avoid relying on slips or skids to control closure - always strive to fly coordinated in close proximity to another aircraft in formation!

If lead must initiate a turn during a straight-ahead rejoin, transition to a turning rejoin and be alert for an overshoot situation, as you may suddenly have excessive closure because of angle (aspect) and airspeed differences.

### 3.3.7 Straight-Ahead Overshoots

#### Lead

Provide a stable platform for the wingman throughout the rejoin. During straight-ahead rejoins, 3/9 line overshoots are not uncommon and must be anticipated. If the overshoot is minor, within one plane length, and under control, the

rejoin may continue. However, do not delay directing the wingman to break out or take other positive action if safety is compromised. If a break out occurs due to an excessive 3/9 line overshoot, the wingman will likely lose sight of you. In this situation, you must be directive in safely reforming the flight (request the wingman roll out on a desired heading, etc.)

### Wingman

A straight-ahead rejoin with excessive closure results in a pure airspeed overshoot. Use idle power and speed brakes as necessary, as soon as excessive overtake is recognized. A small (within one ship-width), controllable, 3/9 line overshoot with a parallel or divergent vector is easily manageable and can still allow an effective rejoin if:

- Visual contact is maintained.
- Flight paths are not convergent
- Number 2 remains in route interval with the overshoot arrested (no aft LOS rate).

If these criteria are not met, regardless of the degree of overshoot, a break-out is mandatory.

If breaking out from a straight-ahead rejoin, maintain adequate lateral separation by turning slightly away from lead and announcing the break out (“Raven 2 breaking out”). Call blind in accordance with Chapter 1 of this manual if visual is lost. Lead may assign a heading to fly or request you roll out to expedite reforming the flight. With lead’s permission, resume the rejoin when lead begins to move forward of your aircraft.

If continuing the rejoin, as lead begins to move forward in your canopy, anticipate the need to increase power and/or retract the speed brakes to achieve co-air speed (no LOS rate) and prevent excessive aft movement.

#### WARNING

When overshooting straight ahead, there is a tendency to move the control stick in the direction you are looking; that is, toward lead. If uncorrected, this action may cause your aircraft to “drift” toward Lead, creating a dangerous situation and requiring a break out.

### 3.4 Summary

Having a solid understanding of how to control closure though management of aspect angle and airspeed are the keys to the rejoin. The concepts covered in this chapter are critical to your success as a safe formation pilot and should be mastered to a safe level before moving on to four ship formation. Instructor’s may utilize exercises such as Offset Trail, presented in the next chapter, to help students quickly master this vital skill.

## CHAPTER FOUR

### Extended Trail



#### 4.1 Introduction to Fluid Maneuvering

Unlike parade formation, fluid maneuvering exercises such as Extended Trail tests your ability to maneuver *relative* to your leader's aircraft. While four ship Extended Trail requirements for a FAST Wingman or Flight Lead rating are limited to non-aerobatic flight, the exercise is designed to encompass a host of aerobatic maneuvers when performed in two ship. This chapter will assist students in mastering closure control, range estimation and aspect awareness relative to a maneuvering aircraft in all dimensions.

Non-aerobatic four ship Extended Trail will be evaluated during the Wingman and Flight Leader RPA practical test at the check pilots discretion using a bank angle limit of 90 degrees. Aerobatic flight demonstration is not required for a FAST Wingman or Flight Lead formation qualification.

#### 4.2 Concepts and Terminology

From chapter three, you should familiar with the following concepts and terms:

- Aspect Angle (AA)
- Heading Crossing Angle (HCA)
- 3/9 Line
- Pure/Lag/Lead Pursuit

- Line Of Site (LOS)
- LOS Rate
- Turn Circle (Tc)
- Closure (Vc)
- Plane Of Motion (POM)

In addition to these, we will now add a few more that will be needed flying the FM exercises presented here.

##### 4.2.1 Turning Room

The airspace between the wingman and leader that can be used to turn and maneuver. See Out Of Plane Maneuvering for additional information.

##### 4.2.2 Out Of Plane Maneuvering (OOP)

Maneuvering out of the lead's Plane Of Motion (POM). When there is insufficient turning room between the wingman and lead's aircraft for in-plane turns, the wingman may choose to maneuver out of plane. Out of plane maneuvers often result in a longer flight path to the desired position, thus controlling closure. See High and Low Yo Yo's.

##### 4.2.3 Lift Vector (LV)

A line perpendicular to the longitudinal and lateral axes,

extending vertically through the top of the aircraft (90 degrees to the wings). The lift vector may approximate the POM of the aircraft with sufficiently applied load factor (G), see figure 4.2.

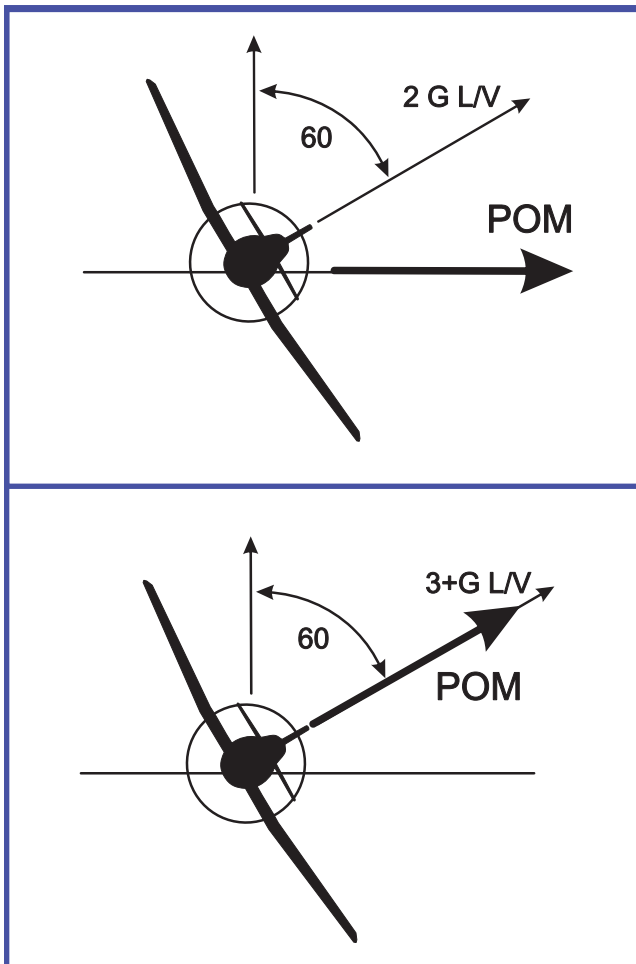

Figure 4.2 Lift Vector (L/V) and Plane of Motion

#### 4.2.4 Hard Deck

An imaginary terrain floor or minimum altitude for maneuvering. The hard deck altitude, in MSL, should be presented in the mission briefing. The hard deck is determined by the highest derived altitude above terrain and/or obstacles in the working, and the minimum altitude needed for recovery from an unusual attitude and/or bailout/ejection requirements. Any pilot detecting a flight member has or will penetrate the hard deck while maneuvering should call KIO.

#### 4.2.5 Corner Velocity

The minimum speed at which an aircraft can obtain maximum allowable G. Corner velocity provides minimum turn radius and maximum turn rate, and is different for each aircraft model/type.

#### 4.2.6 Perch

Often used to set up an FME exercise, the perch is a position left or right of lead, generally at a 30 or 45 degree aspect with

range and vertical displacement as briefed by lead for that particular exercise. (see Offset Trail Exercise, chapter 3)

#### 4.2.7 High Yo Yo

An out of plane maneuver to control excessive closure and/or aspect, using a combination of power, G and lag pursuit. The High Yo Yo is so named because the maneuver is executed above lead's POM. See section 4.5.1

#### 4.2.8 Low Yo Yo

An out of plane maneuver to reduce excessive range and/or increase aspect, using a combination of power, G and lead pursuit. The Low Yo Yo is so named because the maneuver is generally executed below lead's POM. See section 4.5.2.

#### 4.2.9 QuarterPlane

An out of plane maneuver to prevent a 3/9 line or flight path overshoot at close ranges and high line of sight (LOS) rates. A quarterplane is similar to a high yo-yo, but more aggressive. See section 4.5.3.

#### 4.2.10 Energy (E)

Energy is the potential to maneuver, which equates to the capability to climb, increase turn rate and decrease turn radius. It is the sum total of an aircraft's potential and kinetic energy. Potential energy is derived from altitude, while kinetic energy is a function of velocity. The importance of E in flying either the Lead or Wing position during FM is the awareness of the energy state of your aircraft, and how, and when, to transfer potential for kinetic and visa versa. Flying too fast will cause excessive closure resulting in reliance on out of plane maneuvering and/or a flight path overshoot. Additionally, flying low and with inadequate speed may leave you incapable of maneuvering in FM and result in a termination call to regain position, energy or both.

#### 4.2.11 Asymmetrical or Rolling G

The G limitations for most aircraft are specified in the flight manual/POH for the symmetrical case, that is, where both wings are producing an equal amount of lift. Rolling motion is normally imparted by increasing the lift on one wing relative to the other. This asymmetrical lift results in an asymmetrical G loading which is termed 'rolling G'. The effect of rolling G is cumulative with the normal G forces and if rapid rolling motion is imparted during a maneuver already involving a high load factor, then aircraft structural limitations could be exceeded. Caution needs to be exercised in rolling maneuvers because the accelerometer does not indicate rolling G. If a rolling G limitation is not given, a good rule of thumb is to use 2/3 of the symmetrical G limitation as the limit for rolling maneuvers.

### 4.3 Extended Trail

Extended Trail will require mastery of range estimation, aspect management and closure control.

#### 4.3.1 Range and Aspect Exercise:

Accurately estimating range and aspect is fundamental to safely flying formation. This is a simple exercise that should be performed with new formation pilots in preparation for Fluid Maneuvering and Rejoin training. Because the RPA fly's a multitude of aircraft types, the purpose of this exercise is to provide an initial picture for accurate range and aspect angle assessment, and to standardize pilot visual references used to estimate range (see table 4.1). Figure 4.3 provides a graphical depiction of the exercise.

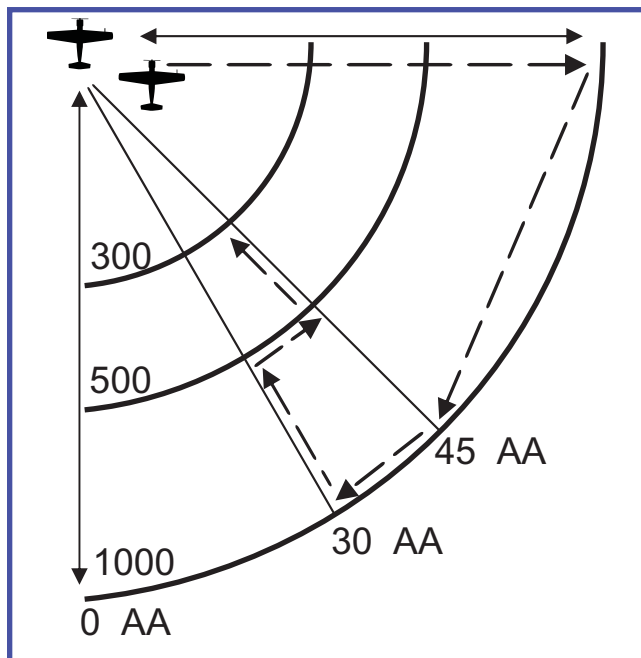

Figure 4.3 Range and Aspect Exercise

4.3.1.1 Set Up and Execution

Number 1 prepares the formation for the exercise with a preparatory radio call, “Raven 2, standby range/aspect exercise.”. Number 2 will acknowledge with full call sign.

Number 1 then gives a command of execution, “Raven 2 cleared to maneuver”. Lead should provide the wingman with a power/airspeed advantage to facilitate maneuvering.

**INSTRUCTORS’ NOTE**

Instructor’s may find this exercise runs more efficiently if they initially fly and demonstrate all range and aspect points to the student, as well as handle all communications required to coordinate the effort. Allowing the student to remain focused on visual references for range and aspect.

The range and aspect set may be conducted on either the left or right side of Number 1. After acknowledging lead’s clearance to maneuver, number 2 moves out to 200 feet line abreast position and momentarily stabilizes. Number 2 calls “Raven 2, 300 feet, 90 aspect” on interplane frequency, and pauses momentarily before continuing out to 500 and 1000 feet line abreast, repeating the call.

Number 2 will then maintain this spacing and move aft, stabilizing momentarily at 45 degrees aspect angle (AA). Number 2 should then continue to 30 degrees AA. Once stabilized at 1000 feet number 2 will close to 500 feet while maintaining 30 degrees aspect. Next, number 2 will maneuver to 45 AA at 500 feet and move to 300 feet, stabilize in position, and request terminate. The momentary pauses allow Number 1 to verbally validate Number 2’s range estimation and AA position.

**INSTRUCTORS’ NOTE**

Judging pure pursuit range is a critical skill for pilots participating in mass formations. Instructor’s may find this exercise useful in teaching proper in-trail ranging at typical intervals (100, 200, 500 ft.). Use of canopy marks to judge relative aircraft size may be helpful in this process (see table 4.1).

If the student can accurately estimate the approximate range and aspect between aircraft, the desired learning objectives have been met. The Flight Lead will then direct a rejoin or proceed with the next FME exercise or profile event.

Range:	Size:	Visual References:
300 Feet	2.1 Inches	Detail visible (canopy details, pilots). Tail star easily recognizable.
500 Feet	1.2 Inches	Canopy detail discernible. Star visible, but not clear.
1000 feet	.06 Inches <small>(20 Inches From Eye)</small>	Aircraft detail lost, tail star not discernable.

Table 4.1 Ranging For Typical 30X30’ RPA Aircraft

4.3.2 Extended Trail

The objective of this fluid maneuvering exercise is to develop the skills to recognize and solve range, closure, aspect, angle off and turning room problems in *all dimensions* to regain and/or maintain a position of mutual support. More advanced Extended Trail involves out of plane maneuvering; thus, students should first demonstrate their mastery of in-

**INSTRUCTORS’ NOTE**

The basic FAST wingman and flight lead ratings are non aerobic formation qualifications. Therefore, the minimum demonstrated proficiency required in extended trail will include non-aerobic maneuvers (turns, steep turns and lazy eights), up to 90 degrees of bank. Aerobic maneuvers such as the wingover, barrell roll and others are not evaluated for the basic wingman or flight lead qualifications.

plane closure control before moving on to more aggressive maneuvering (see level two extended trail).

Both aircraft will initially use a fixed power setting and this will generally remain constant throughout the exercise. This forces the wingman to use the concepts of lead, lag and pure pursuit to maintain the extended trail parameters.

However, during out of plane maneuvering or anytime safety demands, power, may be used as required. The wingman has principal responsibility for collision avoidance while conducting extended trail.

#### 4.3.2.1 Extended Trail Parameters

This exercise is comprised of a cone, aft of lead's extended six o'clock position. For both props and jets, the cone limits are bounded by 30° aspect on the inside and 45° on the outside. The suggested in-trail distances for most propeller aircraft with maneuvering speeds below 150 knots is 200 to 500 feet. For turbine powered or faster propeller aircraft (maneuvering speeds above 150 knots), use 500 to 1500 feet. The minimum distances are provided for reaction time and safety of flight.

In all cases, the inner range limit should be considered as a bubble from the lead aircraft in all dimensions. ***This bubble is a safety-of-flight limit.*** If a wingman penetrates the minimum range bubble, a KIO call is required.

#### WARNING

Because of its dynamic nature, flying Extended Trail requires uncompromising flight discipline. Any pilot in either aircraft will call "knock it off" if safety is ever in question.

#### 4.3.2.2 Momentary Blind In Extended Trail

Unlike parade formation, when range or closure does not pose an immediate collision hazard, momentarily losing sight of Lead during maneuvering may not require an immediate blind call or break out - if Lead reappears immediately as predicted. However, even if range is not an issue, if the other aircraft does not reappear where anticipated, the pilot flying the aircraft that loses sight will call "blind" and the altitude. The visual aircraft will assume formation deconfliction and execute the following:

- If the lead aircraft is blind, transmit "Raven 1 is blind, X,XXX feet" and maintain a predictable flight path. The wingman will either call "continue" and state his or her position relative to Lead, or call "knock-it-off", indicating both aircraft are blind and establish a minimum of 500 feet of altitude separation.
- If the wingman is blind, he/she will transmit "Raven 2 is blind, X,XXX feet" and maneuver away from lead's last known position. If Lead is visual, he/she

will respond with "continue" and provide his/her clock position relative to the wingman, or call "KIO" and execute deconfliction procedures to insure at least 500 feet minimum altitude separation.

#### 4.3.2.3 Extended Trail Entry and set up

Enter Extended Trail from fingertip, route or close trail; direct the entry using a radio call.

"Raven 2, go extended trail"

The Wingman will acknowledge with full call sign and position number. There is no visual signal for extended trail. Lead will then turn away from the flight using up to 60 degrees of bank. The wingman will maintain straight and level just long enough to achieve the desired interval, then turn to maneuver into position on Lead with the designated parameters for his/her aircraft. The turn away by Lead to set range and aspect need not be level—if beginning the exercise below desired maneuvering airspeed, you can use a slightly oblique, descending turn to gain speed.

Based on the level of maneuver, if the wingman finds the initial delay has caused excessive range, he/she should enter the exercise with a low yo yo as required (see section 4.4).

Both aircraft will set the briefed power and maintain it throughout the exercise except as required for safety. Wait for the Wingman to call in position before initiating maneuvering.

#### 4.3.2.4 Flight Lead Maneuver Guidelines

The following guidelines should be considered when leading Extended Trail;

- At all times, you are providing a training platform for the wingman—it is incumbent upon you to maneuver commensurate with the level briefed. To prevent exceeding the wingman's capabilities, consider the skill level of the wing man while maneuvering.
- Use predictable roll rates while presenting reasonable problems to solve in range, aspect and heading crossing angle. Do not execute unpredictable roll reversals that may force the wingman in to a 3-9 line overshoot.
- To aid the wingman in maneuvering, limit straight and level flight while leading extended trail. Vary the attitudes and airspeeds using climbing and descending turns and modified lazy eight/wing-over maneuvers as applicable to the briefed level.
- Be constantly aware of your energy state (altitude, airspeed and G), for the wingman is often exceeding one or more of these parameters to regain or maintain

position. If you are pulling 3 Gs, your wingman may likely be pulling 4 or more to stay in position.

- Brief and remain aware of the hard deck (min maneuvering altitude) at all times; again, the wingman may be lower than your altitude during maneuvering.
- You MUST monitor your wingman's performance. Look over your shoulder to assess where the wingman is positioned. If range or aspect is approaching the limits without apparent correction, back off the aggressiveness of the maneuvering.
- Don't rely on wingman to call out of position; they may not recognize when limits are exceeded or be unwilling to call it because of misplaced pride. Conversely, if the wingman is meeting all the objectives of your current maneuver level, you have the option of calling "terminate" and briefing a higher level of maneuvering.

#### WARNING

Be cognizant of the hard deck—your wing pilot may have very little hard deck awareness. Also, the wing pilot may be lower than your altitude during fluid maneuvering. Call KIO if you perceive either aircraft is or will be below the hard deck.

#### 4.3.2.5 Wingman Maneuver Guidelines

When Lead makes the directive call to go to Extended Trail, acknowledge with your full call sign: "Raven 2." Lead will begin a turn away to allow you to maneuver in to position. Delay for an appropriate interval and then turn to establish your aircraft within the range and aspect parameters required of your aircraft (radial/turbine). When in position with power set, notify Lead with the radio call: "Raven 2's in."

As Lead maneuvers, you will be constantly adjusting your nose position and lift vector orientation to modify your turn circle and plane-of-motion relative to Lead. Recall from chapter three the basic inter-relationship between pursuit curves, range, and aspect angle.

The following guidelines should be followed during Extended Trail:

- Lead's six o'clock position - inside 30 degrees aspect - is a transition area only. Lead can not see you in this position; always strive to remain at 30-45 AA. Fly in a donut around Lead's six o'clock position as depicted in figure 4.1.
- Try to position yourself so you can always see Lead's head/helmet through the side of his/her canopy. This reference will help place you in the 30° to

45° aspect parameters. This oblique view of Lead will also make it easier to judge closure.

- Avoid the high and low six o'clock position as able. If you must cross the upper (Lead's six o'clock high) portion of the cone, do so expeditiously because you and the instructor may momentarily lose sight of Lead.
- Always cross above or below Lead's prop/jet wash and relax back pressure if encountering wash to prevent an over-G. Based on the level of maneuvering, use caution during ET so as to not exceed your aircraft's normal or asymmetrical G limits.
- Since you are not directly in trail with Lead's turn circle/flight path, as long as Lead is turning you will not be able to maintain a fixed position within the extended trail parameters. Do not attempt to stabilize at minimum range, but explore the entire envelope.
- Be cognizant of the briefed hard deck (minimum altitude for maneuvering). Lead is tasked with monitoring your progress and may accidentally

Level	Maneuvers	Bank	G Loading	Restriction
I	Turns, Lazy Eights:	Up to 90°	Up to 2.5G	2 - 4 ship
II	Wingovers, Barrell rolls	unrestricted	Up to 3.0G	2 - 4 ship
III	Loops, Half Cuban Eight, Cloverleaf	unrestricted	Up to 4.0G	2 ship only

**Table 4.2 Extended Trail Maneuvering Levels**

penetrate the minimum altitude. Should you recognize this situation, call KIO immediately.

#### 4.3.2.6 Extended Trail Maneuvering Levels

Extended Trail is divided into multiple levels of maneuvering (Table 4.2). This allows the exercise to be tailored to the student's level of experience, instructor's objectives and/or aircraft limitations.

For example, if the instructor is attempting to demonstrate or critique the students ability to employ the high and low yo yo, level I may be called for to insure the flight lead provides the student with a constant plane of motion to maneuver in reference to. Lead will brief the level of maneuvering and announce the level when sending the flight to Extended Trail. Lead will not transition to a different level of maneuvering without informing the wingman.

##### 4.3.2.6.1 Level One Extended Trial

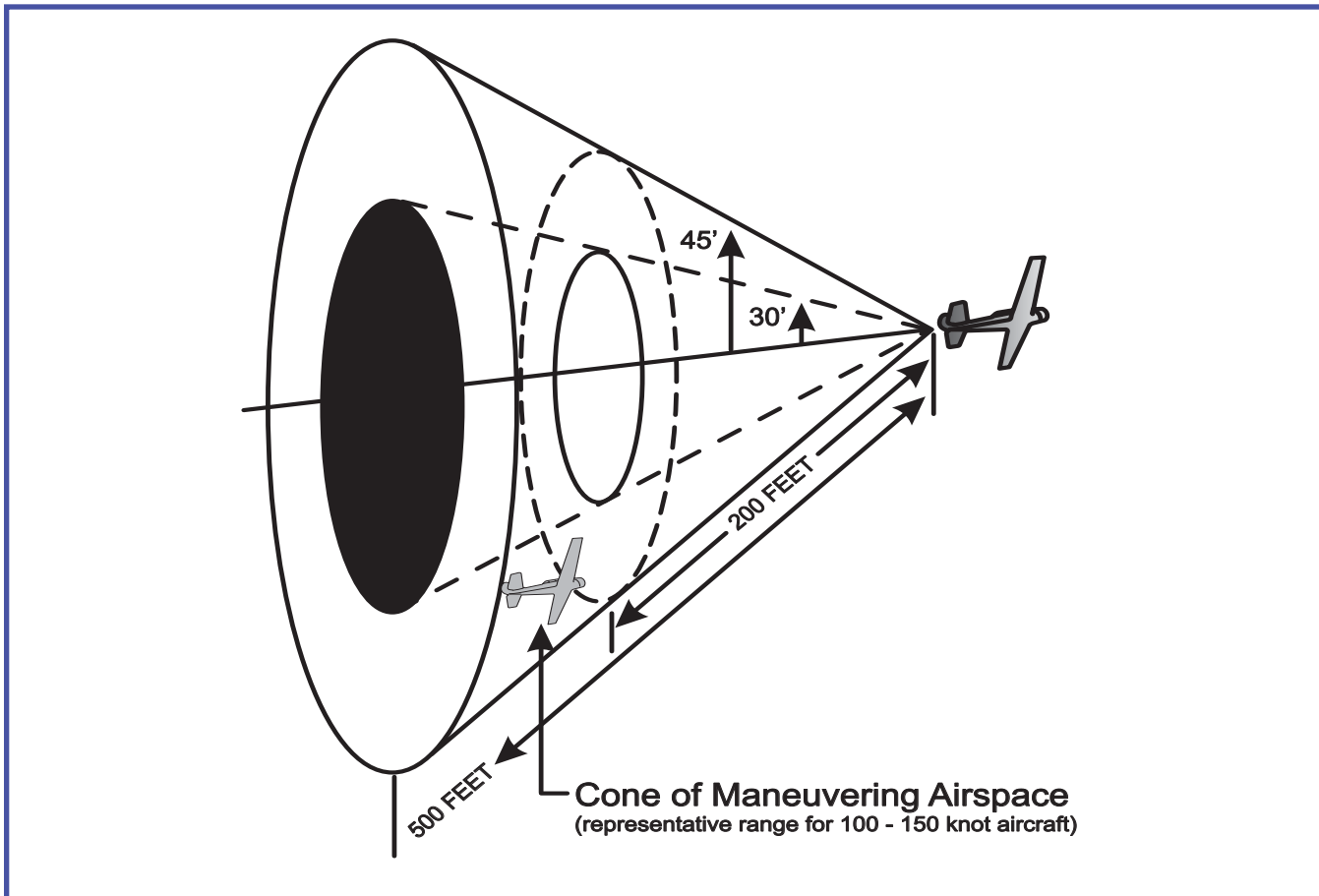

**Figure 4.1 Extended Trail**

Level one Extended Trail is appropriate for demonstrating the use and control of lead, lag and pure pursuit in controlling closure. Level one is flown non-aerobically and will be demonstrated during most basic FAST evaluations for the Wingman qualification. Instructor pilots should provide new students with a demonstration of minimum and maximum range and aspect for their aircraft (jet or prop) before beginning Extended Trail (see ranging exercise, section 4.3.1).

#### **Lead**

Fly level or moderately climbing/descending turns in both directions using a briefed, fixed power setting. Use from 45 to 90 degrees of bank as required. Monitor the wingman's ability to manage range, aspect and closure through timely use of pursuit curves. Use oblique turns if needed to preserve energy. Do not maneuver below the briefed hard deck.

#### **Wing**

With power set as briefed, use pursuit curves to explore the entire range and aspect of the Extended Trail cone. Notice how difficult it is to stay in a fixed position within parameters without maneuvering. Pay close attention to the inter-relationship of lag pursuit and the rapid development of heading crossing angle. Use of moderate high and low yo-yos may help manage closure and range problems in some situations.

If you exceed max range and cannot regain position expeditiously using the low yo-yo, request "Raven 2, request terminate for position". Lead will cease fluid maneuvering and establish a constant rate turn to allow you to regain position. When ready to resume Extended Trail, call "Raven 2 is in". If you exceed the minimum range bubble, call "KIO," and maneuver away from Lead. If necessary, break out.

#### **4.3.2.6.2 Level Two Extended Trail**

Level two is appropriate for student pilots who have demonstrated their ability to accurately estimate and control aspect, range and closure in-plane, and are fully aerobically capable. Level two consists of modified lazy eights (also termed "wingovers") and barrel rolls. If the pilot or aircraft are not capable of aerobically flight restrict all maneuvering beyond 90 degrees of bank (level one).

#### **Lead**

Monitor the wingman's performance, especially during out-of-plane maneuvering; the potential for collision is much higher in level II.

Monitor the hard deck at all times; you must be cognizant of your altitude and your wingman's position in the cone as you maneuver in the vertical. If you find yourself with excessive airspeed and having to pull 4-5 G's to recover from your vertical maneuver/wingover to avoid penetrating the hard-



eck, your wingman may be lower, flying faster, and pulling harder to stay with you.

When performing modified lazy-eights/wingovers, allow the nose to fall to achieve your entry speed, then begin a wings-level pull until the nose passes the horizon. Set the bank angle at 30° to 60° and pull the nose up (as appropriate for your aircraft, normally not to exceed 40° in pitch). As the airspeed decreases, expeditiously roll to 120° of bank and pull the nose down to no lower than 40° nose low. Monitor your airspeed and altitude throughout the maneuver. Roll to reset the bank to 30° to 60° and as the airspeed increases, level the wings, as needed, and begin another pull to continue the maneuver. Alternate the direction of the wing overs as you fly the level-two profile.

When flying the barrel roll, insure adequate energy is maintained throughout the maneuver. Your aircraft should reach the inverted position *before* the nose drops below the horizon in extended trail.

### Wing

Attempt to predict Lead's flight path. Maneuver relative to Lead while maintaining the desired 30-45 degrees of aspect and min/max range for your aircraft —this requires constant analysis of Lead's plane-of-motion as well as relative range, aspect, closure, heading crossing angle, and LOS rate. Avoiding Lead's high and low six o'clock position.

As in level-one maneuvers, if you exceed max range and cannot regain position expeditiously, call "Raven 2 request terminate for position". Lead will cease fluid maneuvering to allow you to regain position. When in position and ready to resume the exercise, call "Raven 2 is in." If you exceed the minimum range bubble, call "KIO," maneuver away from Lead. If necessary, break out.

#### 4.3.2.6.3 Level Three Extended Trail

Level three extended trail will be reserved for advanced formation pilots with full aerobatics qualifications and currency. Maneuvers may include loops, cloverleaves, half cubans as well as the maneuvers already described.

#### WARNING

Flying level three extended trail in more than two ship during selected maneuvers such as the loop and cuban eight, may reverse the direction and energy of the flight back in to the wingmen, resulting in a mid air collision and loss of life.

#### 4.3.2.7 Terminating Extended Trail

The Flight Lead will rejoin the wingman to fingertip when training is complete with a wing rock or radio call.

### Lead

Do not signal for a rejoin while the wingman is maneuvering

significantly out of plane. Instead, establish a level turn of up to 45° bank and maintain it until you see the wingman has stabilized near in-plane. At that time, signal for the rejoin, establishing either a turning or straight ahead rejoin, and adjust power and airspeed to the briefed values. Monitor the wingman closely during the rejoin.

### Wing

When you see Lead stop maneuvering and roll into a level, steady-state turn, you can anticipate that he/she is terminating the exercise and will rejoin the flight. Use lead/lag to establish a relatively stabilized energy state. When Lead signals for rejoin, use standard procedures to rejoin to fingertip.

## 4.4 Out Of Plane Maneuvering

Out of plane maneuvers such as the High and Low Yo-Yo may be called upon during extended trail to control aspect and/or closure. All maneuvers described here utilize the vertical to create, or reduce, turning room when in-plane techniques will not suffice. Your instructor will demo all maneuvers.

Out of plane maneuvering draws on many of the concepts presented in chapter three. To help your understanding of this material, feel free to review the relationship between aspect angle, heading crossing angle, closure and pursuit curves. Many pilots find using their hands, or aircraft models, to replicate the scenarios contained under each maneuver provided below to be helpful in understanding the concepts presented.

### 4.4.1 The High Yo-Yo

The high yo-yo uses the vertical to control overtake, decrease excessive aspect and/or prevent an overshoot by building vertical turning room that would otherwise not exist if maneuvering in-plane with the lead aircraft. The high yo-yo can be a minor reposition or a quarterplane.

#### 4.4.1.1 The High Yo-Yo Scenario

In this scenario, you are inside lead's turn near the forward range limits of extended trail as he/she further increases bank angle into you. In this position, you recognize rapidly increasing aspect, while your range is decreasing and closure is increasing. Lacking adequate in-plane turning room between your aircraft and lead, you choose to employ the high yo-yo to prevent exceeding the minimum range and aspect limits.

- Roll wings level to position your lift vector out of lead's flight path and climb out of plane with lead. Normally, the lift vector is positioned up to 90 degrees to lead's flight path. This climb out of plane slows your forward velocity, controlling closure and provides turning room in the vertical. The degree of climb (vertical pull) is based on range and closure. Maneuvering airspeed must be maintained

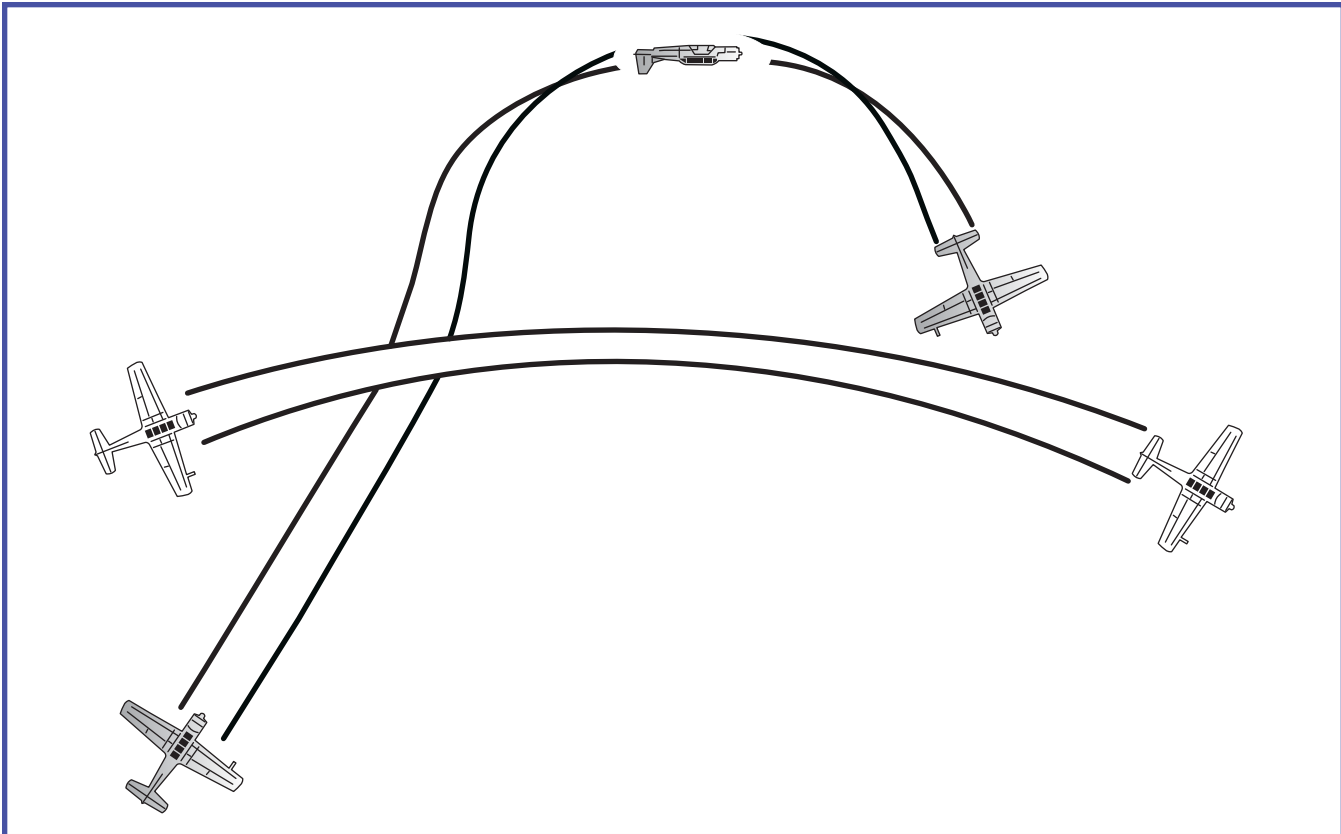

**Figure 4.5 High Yo-Yo** (note: roll to inverted by wingman may not be required in the successful execution of High Yo-Yo)

to use this turning room.

- This initial near-wings level climb out of plane is a lag maneuver, and aspect will decrease. However, as covered previously, lag pursuit results in an increase in heading crossing angle as your heading now diverges from Lead's. If your lift vector was positioned more than 90 degrees to lead's flight path, toward lag pursuit, the resulting rapidly increasing HCA must be corrected by the wingman or excessive range will develop.
- Roll in the direction of lead to maintain visual while positioning your lift vector back in the direction of lead's turn. In this step you are attempting to align fuselages and reduce your heading crossing angle that developed from the initial climb out of plane. Pull toward lead pursuit based on range and closure. During this entire maneuver, keep the lead in site.
- Analyze the effectiveness of the maneuver. If you detect closure is still not resolved, a second high yo-yo may be called for. If the range to lead has grown excessive as a result of the maneuver, a low yo-yo may be called for. If closure and aspect were adequately solved by the high yo-yo, reposition your lift vector in lead pursuit as required.

#### 4.4.1.2 High Yo Yo Common Errors:

- Late or no recognition of the need for the high yo-yo. This may lead to excessive aspect, closure and an overshoot situation.
- Allowing angle off (HCA) to become excessive. This results from pulling too far in the vertical (as a function of time) or relaxing G during the roll to align fuselages with lead. These errors generally result in excessive range developing between the wingman and leader.
- Poor airspeed awareness. This can result in low airspeed developing in the maneuver, preventing the wingman from aligning his/her fuselage or pulling lead pursuit. During out of plane maneuvering, a power increase/decrease may be called for to insure safe maneuvering airspeeds are maintained.

#### 4.4.2 The Low Yo-Yo

This maneuver is designed to reduce excessive range or negative closure using vertical turning room, below lead's plane of motion. See figure 4.6.

##### 4.4.2.1 The Low Yo-Yo Scenario

In this scenario, your range to lead is approaching the aft limit for extended trail as you find yourself outside lead's turn circle in a lag position. You must rapidly resolve this

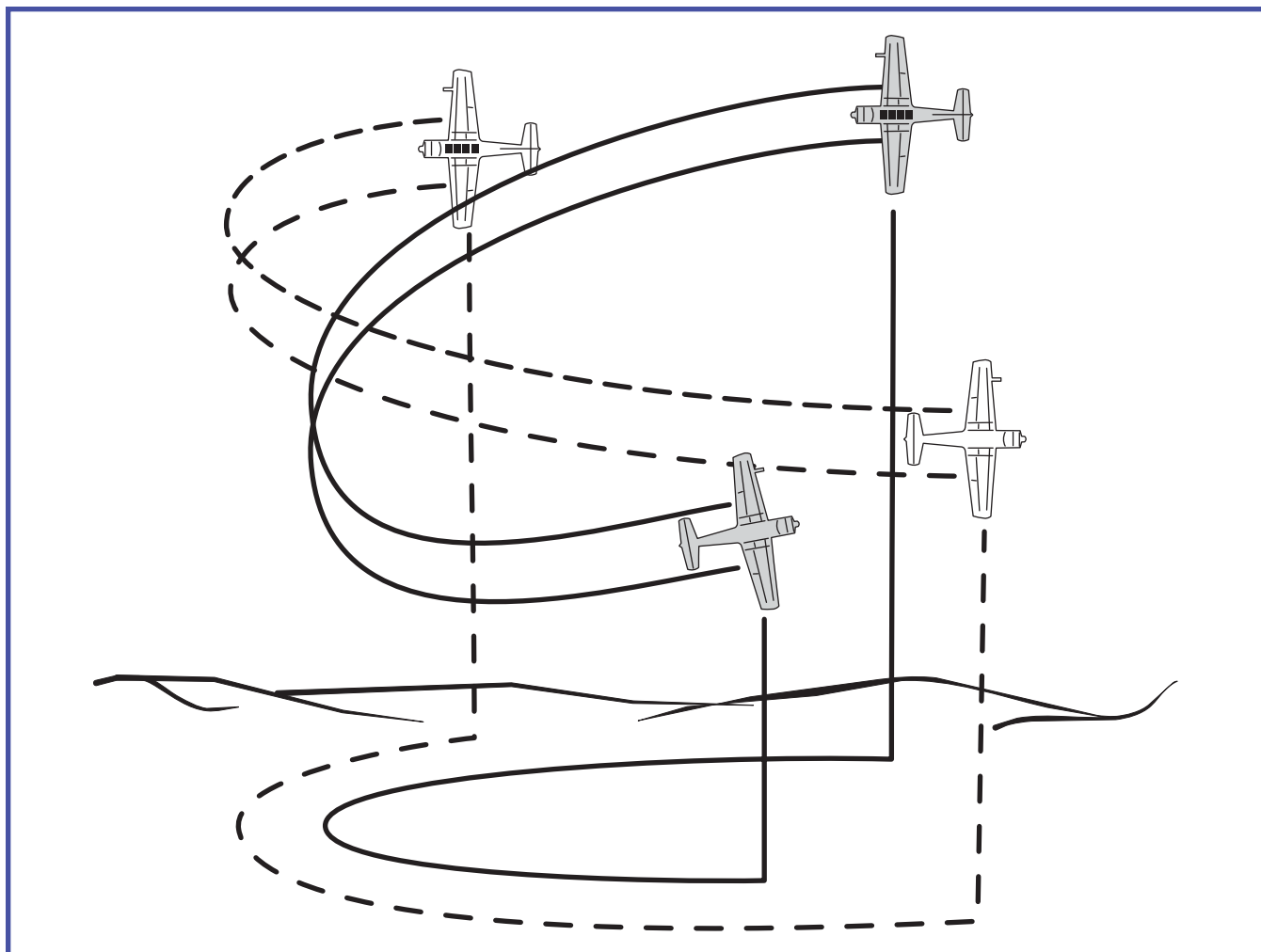

**Figure 4.6 Low Yo-Yo**

range and closure problem to prevent exceeding the extended trail range limits.

- Over bank and set your lift vector in lead pursuit, below lead's plane of motion. This maneuver utilizes turning room below lead's aircraft and preserves/increases forward velocity. In effect, you are cutting across lead's turn circle. How much lead you pull depends on range, closure and the lead's LOS rate.
- As you pull to lead pursuit, analyze lead's movement in your canopy. If the lead aircraft is tracking forward (forward LOS), you probably have to pull more lead. However, if you recognize closure and /or aspect is increasing excessively, reduce your lead pursuit, move to lag pursuit or execute a hi yo-yo as required. The picture in the low yo-yo is similar to a rejoin.
- When the desired range and closure is achieved, terminate the low yo-yo as required.
- Placing the lift vector too low/excessive dive. This can cause excessive airspeed with a resultant large turn circle and/or excessive energy bleed off when pulling your nose up.
- Not establishing sufficient lead pursuit. Failure to pull lead will result in less than desired closure rates.

#### 4.4.3 Quarter Plane

This maneuver is generally a last ditch maneuver to preserve the 3/9 line from a possible overshoot. A quarterplane is similar to a high yo-yo, but more aggressive, see figure 4.7.

##### 4.4.3.1 The Quarter Plane Scenario

In this scenario, you find yourself on the inside of lead's turn with minimal range, excessive aspect and significant aft LOS rate. Taking no action, your aircraft will exceed the 45 degree extended trail aspect limit and quite possibly experience a 3/9 line overshoot and KIO situation.

- Roll out of plane and pull to lead's high six o'clock. The roll and pull out of plane may be more than

#### 4.4.2.2 Common Errors

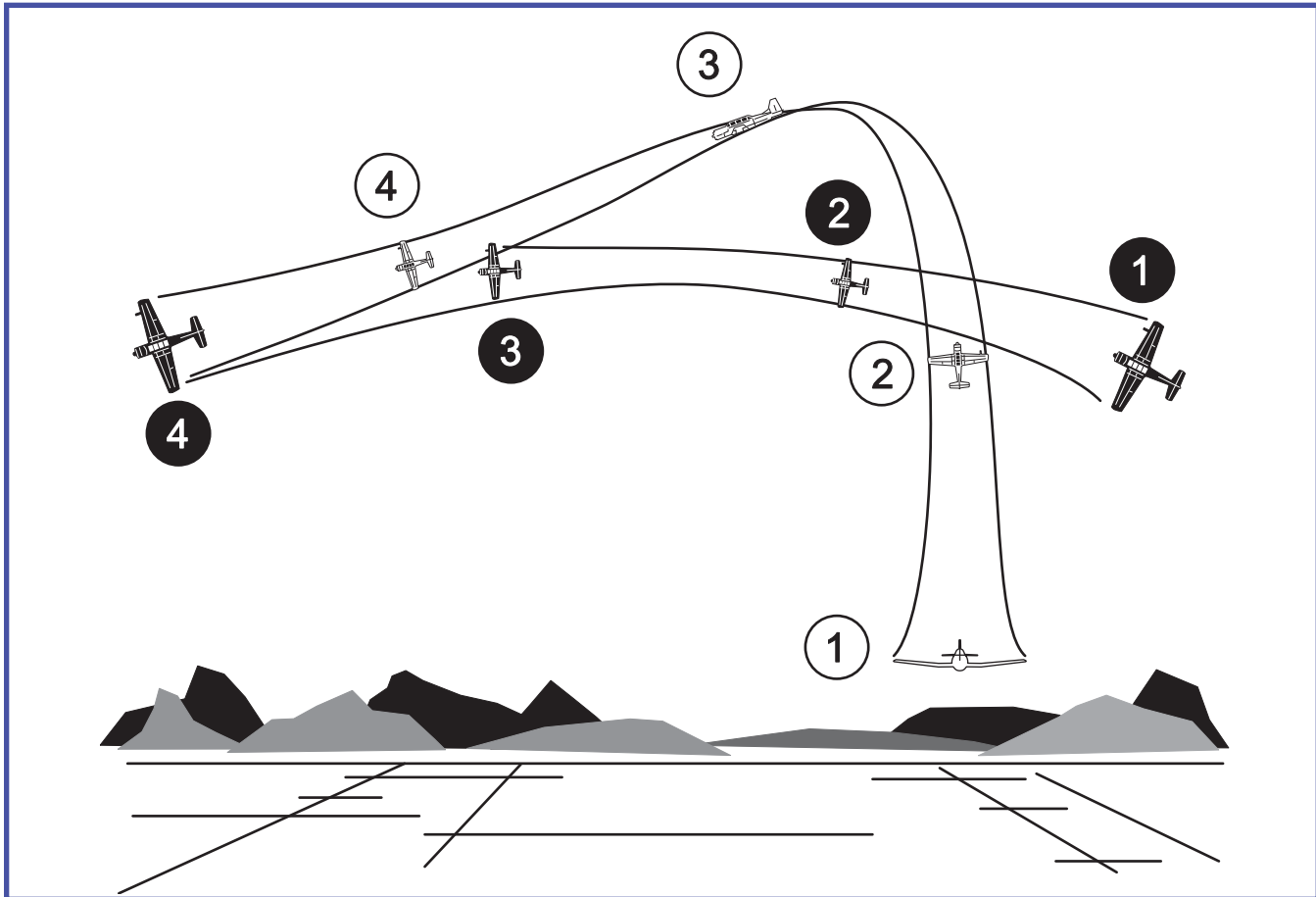

**Figure 4.7 Quarterplane**

90 degrees from lead's plane, but the amount is dependant on range, closure and aspect. This pull to the lead's high six rapidly reduces closure and aspect, preventing a 3/9 overshoot.

- Unload to near 1 G and roll in the direction of lead's turn and regain/maintain visual while analyzing lead's LOS rate on your canopy. If this LOS rate is aft, the closure problem is probably not solved and a second quarterplane or hi yo-yo may be needed.
- If closure is under control, orientate your lift vector to align fuselages as required. Often with the quarterplane, a low yo-yo is required to correct the increasing range.

#### 4.4.3.2 Common Errors:

- Executed too late or not at all. Failure to quarter plane when needed may result in a 3/9 overshoot.
- Not pulling aggressively to lead's high six. Again, an overshoot may occur.
- Late to asses the situation after executing. Excessive delay to recommit after the lag maneuver

may cause enough angle off (HCA) and range from lead to exceed extended trail parameters.

#### 4.5 Summary

Fluid maneuvering exercises are designed to help produce a safe formation pilot that can recognize, react, and control, varying situations of range, closure and aspect. While many pilots have achieved considerable skill in maintaining the close formation position, it is the pilot that can safely, and efficiently, regain a position of mutual support from any range or aspect that has truly mastered his/her art.

## CHAPTER FIVE

### Four-ship Formation



#### 5.1 Introduction to Four Ship Formation

The basic formation positions, techniques and procedures described in two-ship formation apply equally to three and four ship. Additional formations, such as finger four and diamond, will be introduced in this chapter.

##### 5.1.1 Four Ship Organization

In four-ship formation there will be two elements and therefore two element leaders. The first element Lead is designated as the over-all Flight Lead, while the second element is commanded by the Deputy Flight Lead. As you learned in chapter two, 2 ship formation, each element is assigned a Wingman; making up the number 2 and 4 slots respectively.

Elements (Lead and Wingman) maintain integrity within the four-ship. As an element Flight Lead, number 3 must give consideration for number 4 at all times.

#### WARNING:

Unless provided for during pilot training under the supervision of a backseat instructor, never place a non-formation qualified or inexperienced pilot in the position of Flight Lead.

##### 5.1.2 Formation Briefings

Three- and four-ship formation flying requires thorough attention to detail from mission planning and the preflight briefing to the debriefing at the completion of the flight. All members of the formation will be present for the briefing. See appendix C for further guidance on briefings and debriefings.

##### 5.1.3 Four-Ship Formation Communications

Follow all procedures as outlined in chapter one, Basic Formation Principals. As previously discussed, use of full word and number call sign is mandatory when responding to a directive from the Flight Lead or other formation aircraft, and when announcing self-initiated actions, such as a break out. In addition, full word and number call sign should always be used for the party you are addressing; never address a flight member over the radio by position number alone to preclude confusion.

#### CAUTION:

When passing along visual signals in four-ship in the Wingman position, do not look away from your Leader for an acknowledgment.

#### 5.2 Ground Operations

##### 5.2.1 Engine Start, Check-In and Taxi

All applicable engine start, check-in and taxi procedures as outlined in chapter two apply to four ship. All Wingmen except number four will configure with navigation lights on and beacon/strobe lights off. Number four will configure with navigation and anti-collision/strobes lights on if so equipped.

The Flight Lead must ensure his/her taxi speed allows proper flight interval. Wingmen will insure they are in proper sequential order when leaving the parking area. If a general aviation aircraft attempts to taxi between departing formation aircraft, the Wingman should request the aircraft hold position momentarily to allow the formation to maintain

integrity. Match the Flight Lead's configuration during taxi out.

### 5.2.2 End of Runway Lineup

As in two ship, the formation will position themselves, space allowing, line-abreast with no wing tip overlap. Number two should stop line-abreast with the Flight Flight Lead, and number 3 and number 4 will attempt to line up the helmets/heads of preceding aircraft. Due to limited space at most airports, the potential for collision is high.

When all aircraft are in position, brakes set and ready for run-up, number four will pass a thumbs-up to three. The signal will be relayed up the line to the Flight Lead by each aircraft in sequence. The Flight Lead will then provide the run-up signal in accordance with appendix A to start the engine power and pre-takeoff line-up checks. Use caution when applying power for the engine run up to prevent creeping or turning. When number four's run up and all checklist items are complete, he/she will again provide the thumbs up to three and all aircraft will relay the signal in turn signifying they are ready for immediate takeoff.

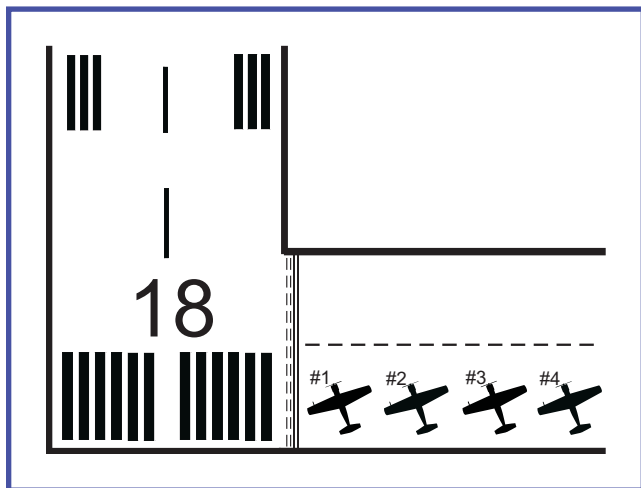

Figure 5.1 End Of Runway Lineup

As an alternative, the Flight Lead may brief for all flight members to perform "independent run-ups". This allows all aircraft to independently run power and pre-takeoff checks upon arrival to the designated run-up area. The only hand signal required is a thumbs up relayed in-sequence as above, indicating the flight members have completed all checklists and are ready for immediate takeoff.

At this time the Flight Lead will send the flight to the tower frequency as required and coordinate for take off clearance.

## 5.3 Formation Takeoff

All pilots should be familiar with section 1.2 "Recommended Operational Maneuver Limits and Restrictions" pertaining to formation takeoff procedures.

As you learned in Two Ship, there are two basic formation

takeoff procedures; Element and Interval. Section 5.3 provides several lineup options, all of which can be used for either element or interval departures with an adequately wide runway.

If the runway width is too narrow to allow two aircraft to pass one another with at least ten feet of lateral spacing, flight leads should employ "lift off" as the minimum interval between aircraft and use the centerline for departure as required. The Flight Lead should brief the appropriate procedure during the mission briefing.

### CAUTION

Provide adequate space between your aircraft and the edge of the runway. Do not position aircraft dangerously close or off the prepared surface simply to achieve the minimum lateral spacing.

### 5.3.1 Runway Lineup

Whether conducting element or interval procedures, if the runway width allows, the Flight Lead will assemble the entire flight on the runway for takeoff using one of the briefed lineup options described below. While each option requires a different minimum runway width, all element (formation) takeoffs must provide a minimum of ten feet lateral separation between leader and wingman (20 feet desired for initial training). If the runway does not comfortably provide for this, use interval departure procedures provided in this chapter.

Although the flight has more flexibility in runway width required for interval (single ship) departures, due to the possibility of brake fade, particularly after a long taxi out, it's recommended to avoid lining up with wingtip overlap in element (offset) or echelon lineup procedures unless the Flight Lead has specifically briefed to remain at idle power until brake release (no engine run up).

If runway width, airport restrictions or other reasons preclude entering the runway as a formation, use a feed-on method and rejoin after departure.

#### 5.3.1.1 Split Element Lineup (100-500 foot Spacing)

This is the preferred option for initial student training. Use this lineup if critical field length is not an issue and/or runway width precludes one of the other options. Runway width required for most RPA aircraft is 100 feet when using this option for element takeoffs.

For this lineup, the first element will position themselves approximately 100-500 feet down the runway with each aircraft taking the center of their respective side, insuring a minimum of ten feet of wingtip separation between aircraft (20 feet desired for initial training) for element departures.

The second element will lineup behind the first with ad-

equate in trail spacing to avoid prop/jet blast. Larger horsepower or turbine powered aircraft may need to offset elements to further avoid engine blast/foreign object damage as needed. See figure 5.2.

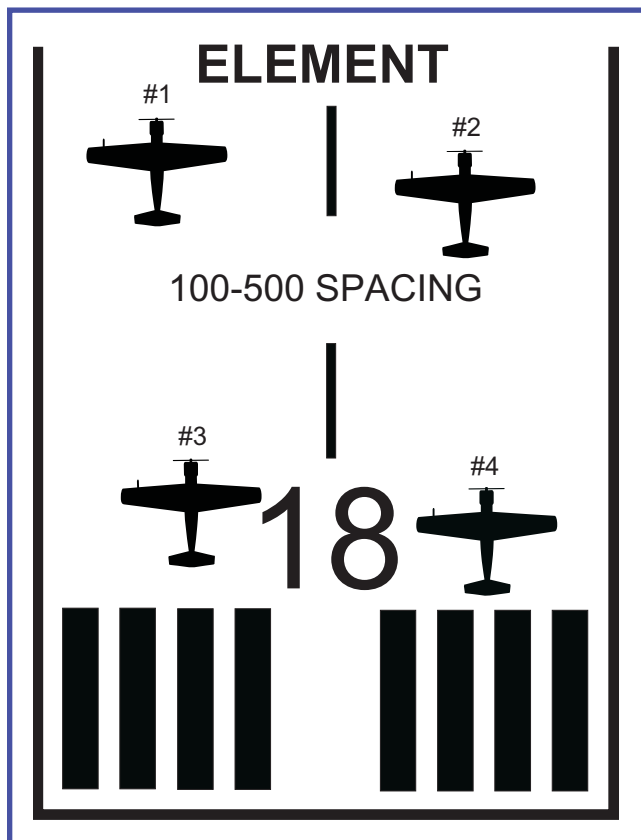

Figure 5.2 Split Element Lineup (100-500 Foot Split)

When four is in position and ready for runup, he/she will transmit “Raven four’s ready”. At that time the flight lead will proceed with briefed formation or interval takeoff procedures in accordance with this chapter.

**5.3.1.2 Offset Element Lineup**

Use this configuration if runway/critical field length is a consideration. For aircraft with wingspans under 35 feet, a 150 foot wide runway will allow lineup with little or no wingtip overlap between aircraft.

The Flight Lead will position him/herself as far to the side of the runway as practical. Two will place the wingtip closest to the Flight Lead on or near the centerline of the runway. Number three will lineup between the Flight Lead and number two, while four will lineup offset from number two’s prop/jet blast in the normal “acute” position with number three. See figure 5.3.

**5.3.1.3 Echelon Lineup**

If conducting element takeoffs, this option requires a minimum runway width of 200 feet for most RPA aircraft. If ele-

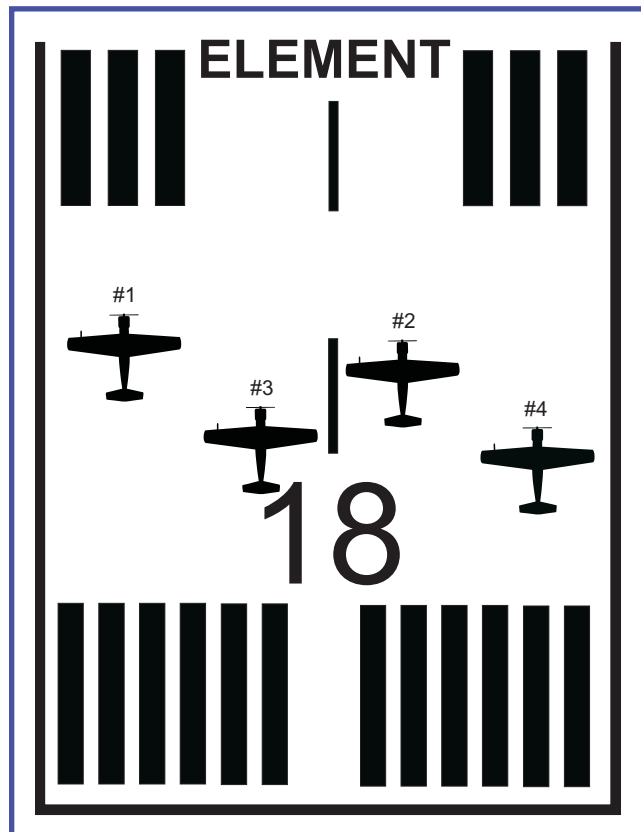

Figure 5.3 Offset Element Lineup Option

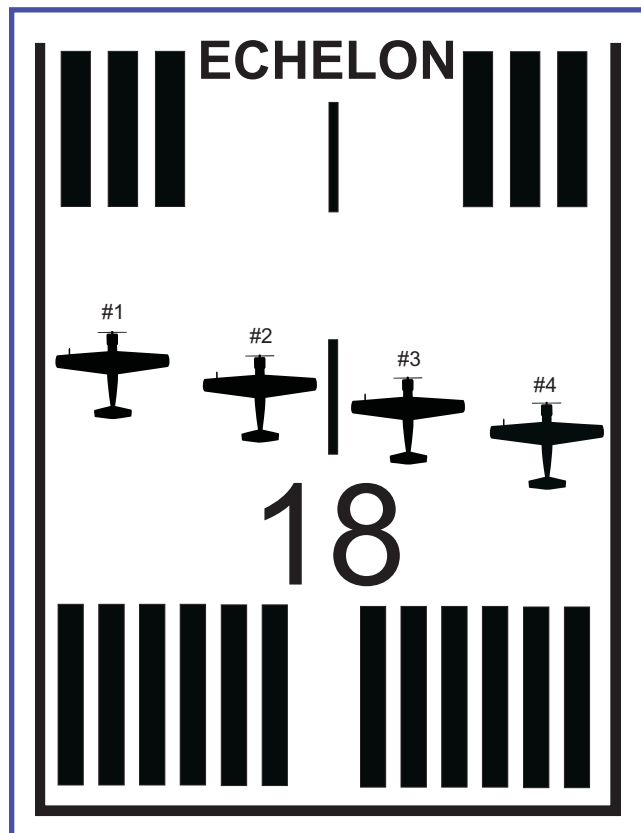

Figure 5.4 Echelon Lineup Option

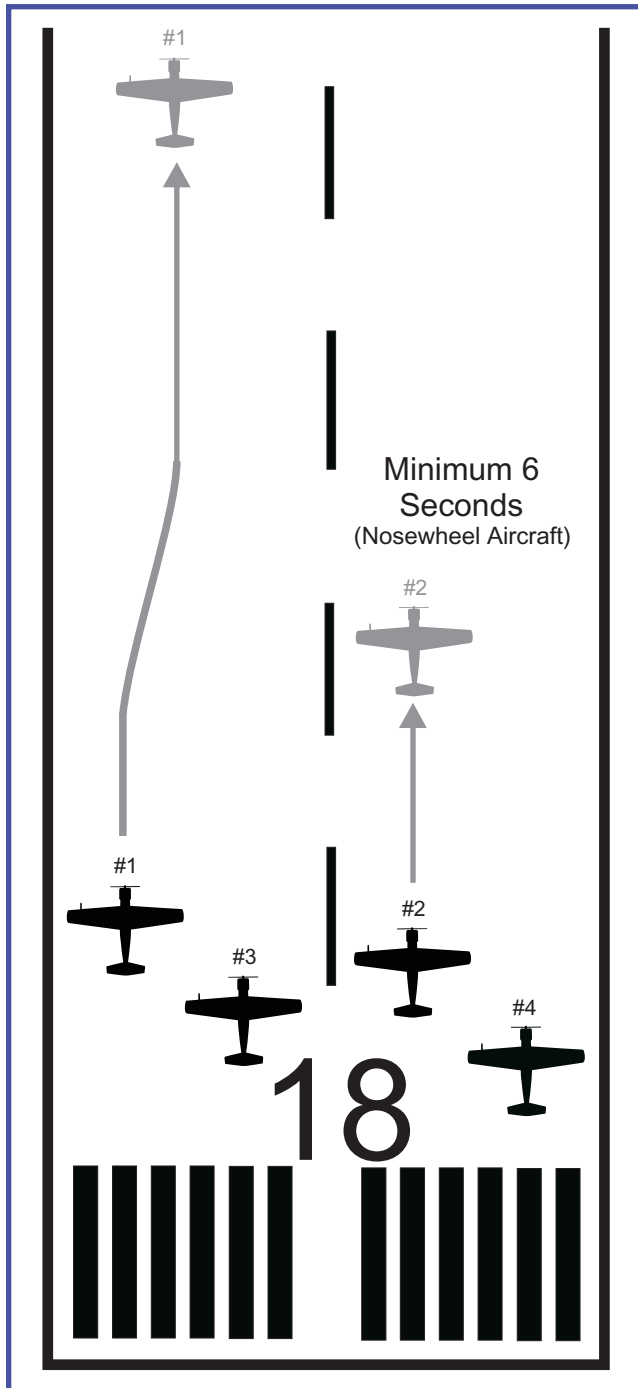

Figure 5.5 Interval Takeoff - 150 Ft. Wide runway

ment aircraft will not have a minimum of ten feet of wingtip clearance, use interval departure procedures or select another lineup option.

For echelon, one will lineup as far to the side as practical. Two lines up with a minimum ten feet wingtip clearance if conducting element takeoffs. Three will lineup on his/her side of centerline and four use the same spacing as two while aligning the helmets/heads of one, two and three.

### 5.3.2 Interval Takeoffs

Single ship interval takeoffs using the guidance in this chap-

ter offer an efficient process for launching a large number of formation aircraft safely.

When all aircraft are in position, number four will transmit “Raven four’s ready”. Alternatively, if using Element Offset or Echelon lineup procedures, normal visual signals can be used with four providing a head nod to number three when ready for takeoff. The signal will then be passed up the line to number one. The Flight Lead will then runup his/her engine to the prebriefed power setting and release brakes and set max/desired takeoff power. Numbers 2, 3, and 4 may delay their runup a few seconds.

Takeoff interval between *nosewheel* configured aircraft will be as briefed by the flight lead, but should be no less than 6 seconds. Each aircraft will maintain his/her side of the runway during the takeoff roll, all aircraft may steer toward the center of their half of the runway after brake release. See figure 5.5.

If the runway is too narrow to provide a clear lane for each accelerating aircraft, steer toward the centerline after brake release and do not release brakes until the preceding aircraft has rotated and lift off can be assured.

Formations consisting of widely dissimilar and/or tail wheel aircraft configurations should not release brakes until the preceding aircraft has rotated and lift off can be assured.

### 5.3.3 Element Takeoffs

When four is in position for takeoff, he/she will transmit “Raven four’s ready”. Alternatively, if using Element Offset or Echelon lineup procedures, normal visual signals can be used with four providing a head nod to number three when ready for runup. The signal will then be passed up the line to number one. The Flight Lead and his/her Wingman will then execute an element takeoff in accordance with the procedures contained in chapter two.



Image 5.1 Wingman View of the Element Takeoff



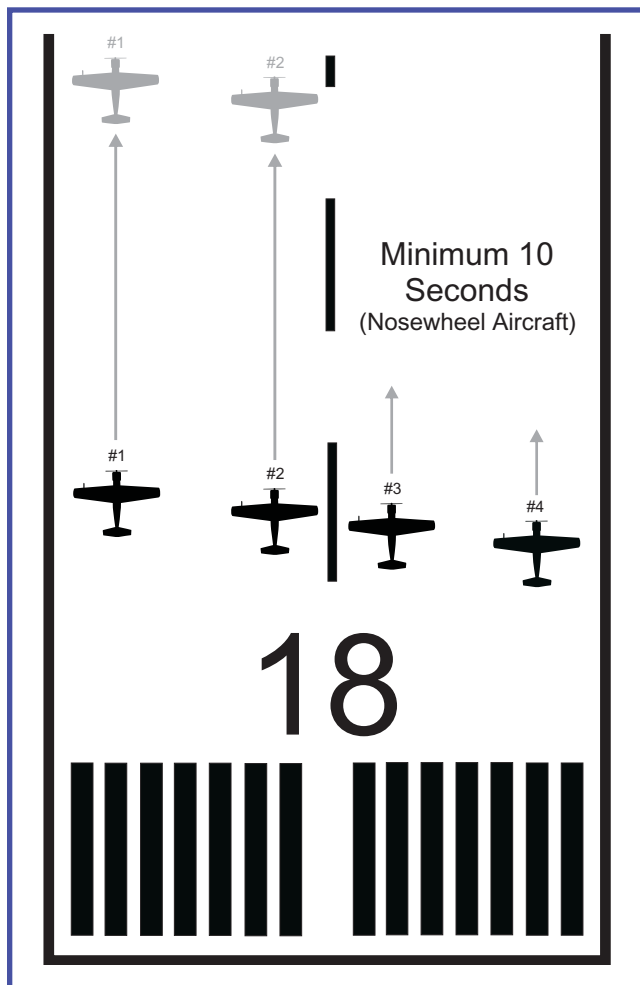

Figure 5.6 Element Takeoff - 200 Ft. Wide Runway

**INSTRUCTOR NOTE**  
 During initial student training, use “liftoff” as the minimum interval between elements.

The second element will do the same, delaying their runup a few seconds as desired. Release brakes as briefed by the flight lead, but in no case less than ten seconds after the first element begins to roll. If operating tailwheel aircraft, or widely dissimilar aircraft, delay brake release until the preceding element rotates for takeoff.

**WARNING**  
 Element and Interval takeoffs require prompt recognition and communication in the event of a takeoff abort. See chapter 6, *Abnormal Operating Procedures*, for all abort procedures.

## 5.4 Departure

### 5.4.1 Rejoining After Element Departures

The flight will rejoin to the finger four configuration (see

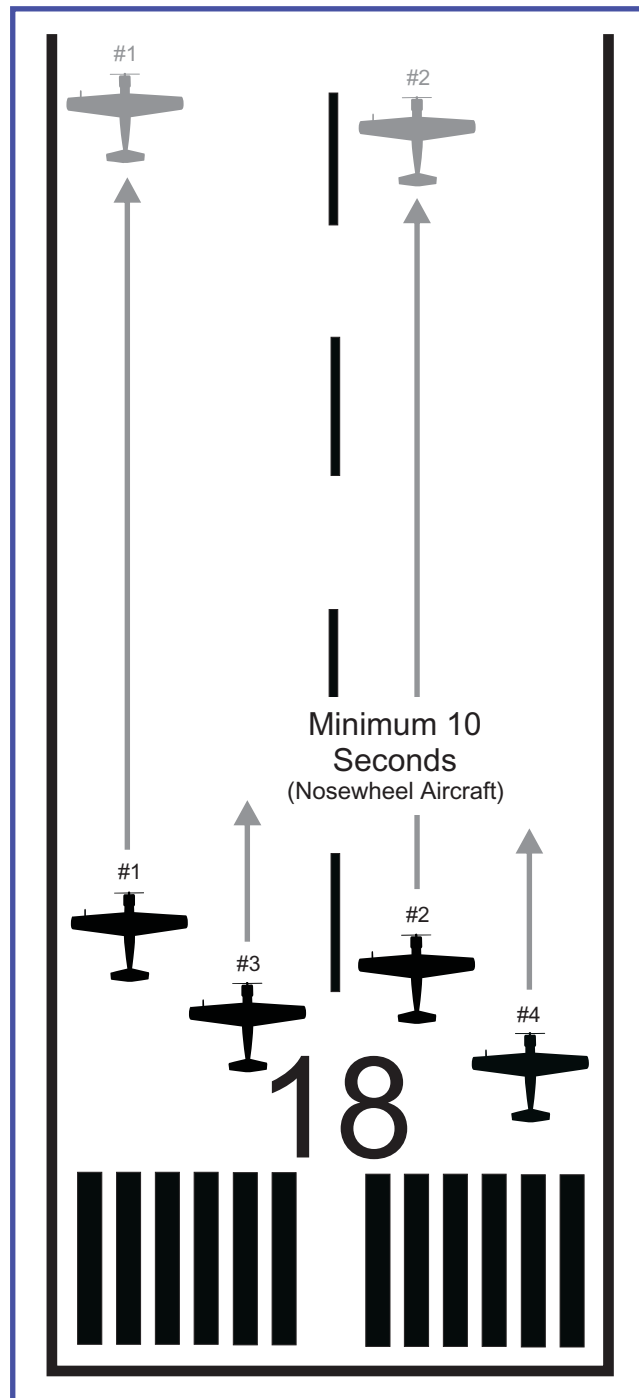

Figure 5.7 Element Takeoff - 150 Ft. Wide Runway

figure 5.8). The type of rejoin will depend on the local departure procedures. It may consist of a turning rejoin, a straight ahead, or a combination of both. During a turning rejoin, three and four will rejoin to the outside of the turn. During a straight ahead rejoin, three and four rejoin to the opposite side of number two.

### Flight Lead

The Flight Lead should maintain a stable platform for the trailing element and maintain the briefed power and airspeed until the second element is rejoined. Inform number three if any abrupt maneuvering is required prior to join up

(traffic/terrain avoidance, etc.)

### Two

If the initial turn out of traffic is away from you, expect lead to cross you over to the inside of the turn in anticipation of rejoining the second element. Do not execute a crossunder below 400 feet agl.

### Three

After airborne with gear and flaps retracted, four should be positioned to route during the element rejoin to allow greater maneuverability. As the second element, three and four will always rejoin to the outside of leads' turn, *or the opposite side of number two*. If accomplishing a turning rejoin, place number four on the inside of the turn as soon as conditions permit. During the rejoin, avoid sudden power changes or abrupt flight control inputs.

### Four

Follow all two ship takeoff procedures. When in route formation during the element rejoin, maintain approximately 100 feet separation (2-4 ship lengths) and monitor number three's rejoin while not sacrificing your formation position. Return to fingertip when number three has completed his/her rejoin.

During turning rejoins, because your element will rejoin to the outside of the turn, cross to the outside of three as three crosses the lead element. Use caution if number three

appears to have excessive closure or aspect on the lead element; do not collapse your spacing on three until you are assured his/her rejoin is stable. Trust number three, but be prepared for a break out if a conflict arises.

### 5.4.2 Rejoin After Interval Takeoff

If single ship departures were required, the flight will assemble individually to the finger four configuration. During a turning rejoin, number two rejoins to the inside of the turn and three and four to the outside. For a straight ahead rejoin, two will rejoin to the left side unless briefed otherwise, with three and four rejoining on the opposite side of two.

### Flight Lead

Maintain briefed power and airspeed settings until the rejoin is complete. If air traffic control or other circumstances require changing from a straight ahead to a turning rejoin, inform the flight if able.

### Wingmen

Use applicable guidance in chapter two on basic rejoin procedures and section 5.7.2 of this chapter for executing the four ship rejoin. Begin the turn out of traffic at or above 400 feet in accordance with the Aeronautical Information Manual (AIM) or host nation guidance and maintain at least 100 foot spacing from the preceding aircraft until that aircraft has rejoined to the proper position. If executing an overshoot, inform the flight with a radio call using full call sign, i.e. "Raven 2 is overshooting".

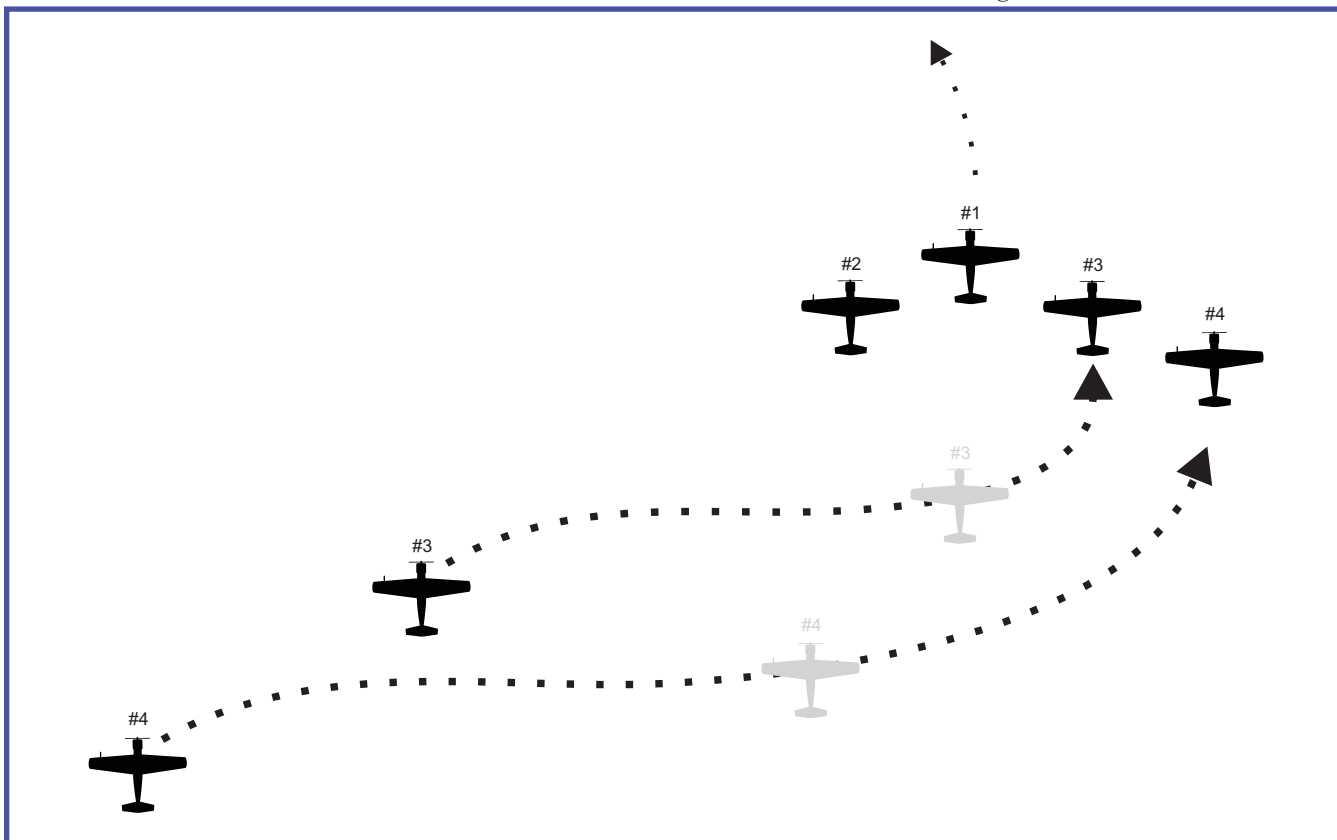

Figure 5.8 Four Ship: Second Element Turning Rejoin to the Outside

## 5.5 Formation Positions and Maneuvers

Unless specified otherwise, the number 1 and number 2 positions and procedures covered in chapter two are applicable to four ship formation.

### 5.5.1 Finger Four

Finger four is the standard close formation configuration, and is so named after the likeness to the fingertips on your hand. Finger Four can be flown strong right or strong left, as desired by the Flight Lead (Figure 5.9). The term “fingertip”, if used during four ship operations, refers to the “finger four” formation.

As four, fly the normal fingertip position off three while striving to line up the helmets/heads of one and three. If three is having difficulty in holding a smooth, consistent position, fly a stable position off one, while constantly monitoring three.

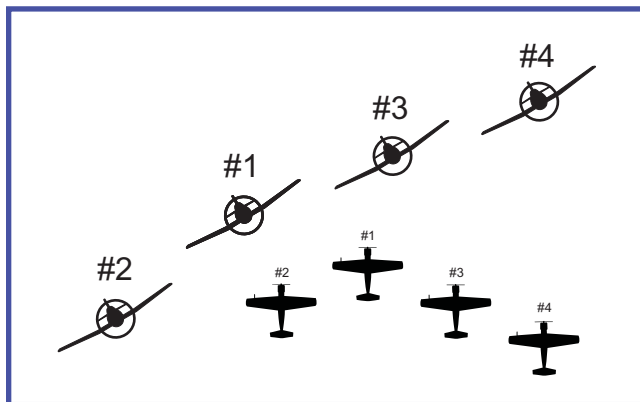

Figure 5.9 Finger Four (strong right)

### 5.5.2 Route

The purpose, parameters and signals for four ship route formation are identical to two ship. Ideally, the formation will appear as a finger four with 2-4 shipwidths of spacing between aircraft. This lateral interval may be as much as 500 feet between aircraft for enroute purposes if briefed by the Flight Lead.

Number two sets the spacing in route. Three should fly line-abreast of number two matching the lateral spacing from one. Four should line up the helmets/heads with number three and one. In addition, four will strive to match the lateral spacing that three has with number one.

As you learned in chapter two, all turns use echelon procedures for wingmen on the outside of the turn. Wingmen on the inside of the turn will descend only as required to keep the Flight Lead in sight.

### 5.5.3 Cross-Unders

Cross-unders are used in four ship to transition from fingertip strong right to strong left (vis versa), or reconfigure to and from echelon formation. The default visual signal for cross-unders in the RPA is hand signals in accordance with

Appendix A. However, aircraft signals (i.e. “wing dip”) are covered here and may be used if briefed by the Flight Lead.

Do not “mix” aircraft and hand signals for the cross-under in the same sortie; if not briefed otherwise, the use of hand signals is expected. Flight Lead’s will avoid maneuvering during cross-unders with students in training.

#### 5.5.3.1 Wingman Cross-Under

Except for additional guidance on executing element cross-unders as number four below, follow applicable procedures provided in Chapter 2 (two ship formation) in responding to a directive to cross-under. When in fingertip formation and the Flight Lead wishes to transition to echelon by moving number two over, the second element will move out to provide room for number two to take up his/her new position on the opposite side. See figure 5.10 and expanded explanations below.

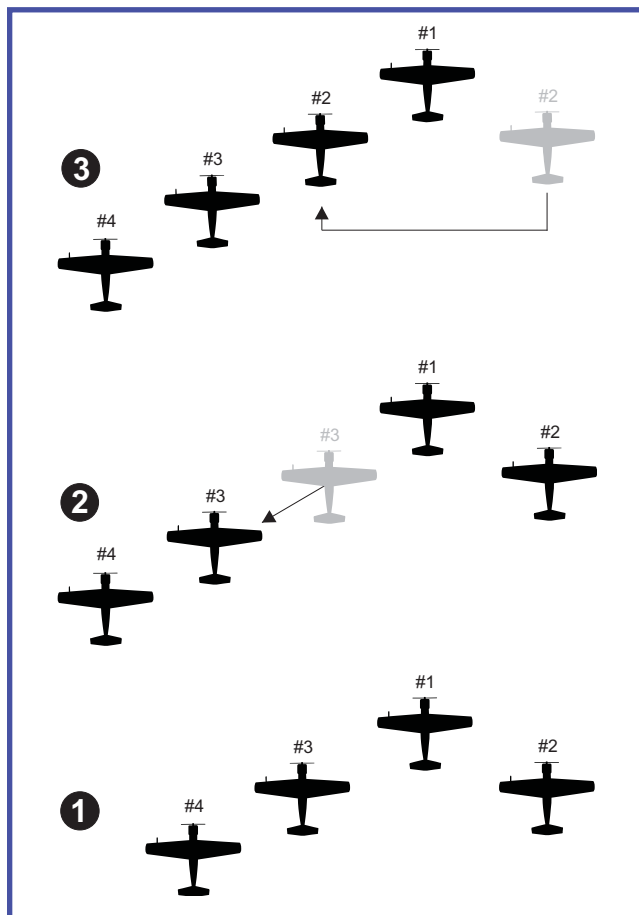

Figure 5.10 Wingman Cross-under to Echelon

#### 5.5.3.2 Element Cross-Unders

In four ship, the Flight Lead may move the second element to the opposite side at one time, together, using one visual signal or radio call. Upon acknowledgment of the Flight Lead’s directive, number 3 will cross under using the same procedures as outlined in chapter 2, while number 4 will cross-under number 3 as the element transitions to the other side of the flight. See figure 5.11.

### 5.5.3.3 Cross-Under: Using Hand Signals

#### Flight Lead

The Leaders's basic hand signal is an extended forearm held vertically with the fist clenched as detailed in Appendix A. If the fist is held stationary in the cockpit, it indicates a single-ship cross-under for number 2. If the fist is "pumped" up and down twice, it indicates an element cross-under for number 3 and 4 as covered below.

When signaling the second element to cross-under from fingertip strong left to strong right (or visa versa), the Flight Lead will provide two "hand pumps" as covered above and look for an acknowledgment from the Deputy Flight Lead (number 3). No further action is required. Monitor the second element's transition through the cross under. Number two remains in position. The flight will now be in echelon configuration; see figure 5.11.

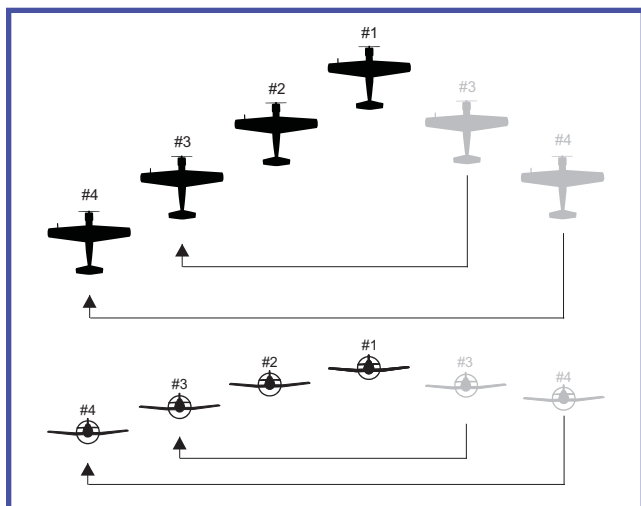

Figure 5.11 Element Cross-Under to Echelon

To move only number two from one side to the other, the stationary clenched fist is used. If moving number two to the *same side* occupied by the second element to form the flight in echelon, provide the single-ship cross-under signal to number three *first*. Once acknowledged by number three, provide the same signal to number 2, who will acknowledge and execute the cross-under in accordance with chapter two. This ensures the second element will move out to provide space for number 2 to take up the parade position (see figure 5.10)

#### Wingmen

All applicable cross-under procedures covered in two ship formation apply to four ship. If a single hand pump (stationary clenched fist) is given to number 3, he/she will acknowledge the signal and move to route and anticipate a cross-under by number 2 to take up position next to the Flight Lead - see figure 5.10.

If the Flight Lead directs an element cross-under by giving the double hand pump signal to number 3, number 4

will move with number 3 and simultaneously cross-under number 3 as he/she transitions behind the Flight Lead. In all cases, use the same basic three step process as you learned in two ship formation.

### 5.5.3.3 Cross-Under: Using Aircraft Signals

#### (Wing Dip)

The wing dip is an alternate cross-under signal that may be used if briefed beforehand by the Flight Lead.

#### Flight Lead

The wing dip should be a small, deliberate and quick displacement of the ailerons. Avoid a slow and excessive control movement that could confuse the procedure with the initiation of a turn by the Wingmen.

#### Two

As you will recall from chapter two, 2 ship formation, a wing dip away from your position is the command to cross-under. Follow applicable procedures from chapter two. If wing dip is toward you, hold position as the Flight Lead is commanding the second element (number 3 and number 4) to cross-under to echelon.

#### Three

When in finger four, if the wing dip is away from your position, execute an element cross-under. Number 4 will simultaneously cross-under number 3 as you transition behind the Flight Lead. Use the same basic three step process as you learned in two ship formation.

If the wing dip is toward you while in fingertip, the Flight Lead has commanded number two to cross-under to your side. You should expeditiously move out to provide adequate space for number 2 to take up position between yourself and the Flight Lead

#### Four

A wing dip away from the second element (i.e away from number 3 and number 4) signifies an element cross-under. As number three executes a normal cross-under, you will simultaneously cross-under number 3 as the element transitions behind the Flight Lead. Use the same basic three step process as you learned in two ship formation.

### 5.5.4 Echelon Formation

Four ship Echelon procedures and maneuvers are conducted the same as in two ship with all aircraft on one side of Flight Lead. In this configuration, all turns away from the formation will be conducted using the in-plane echelon turn as described in chapter two. For initial FAST qualification, use up to 45 degrees of bank.

#### Flight Lead

To re-configure the flight to echelon use the single or element cross-under procedures as covered above using a radio call, hand signal, or aircraft signal (wing dip) as briefed. If



**Image 5.2 Echelon Formation**

using the radio, transmit, “Raven Flight, Echelon Right/left”. As in two ship echelon, except for very small turns in to the Wingmen, all maneuvering will be away from the flight. Smoothly roll to the desired angle of bank and avoid fluctuations in G (load factor).

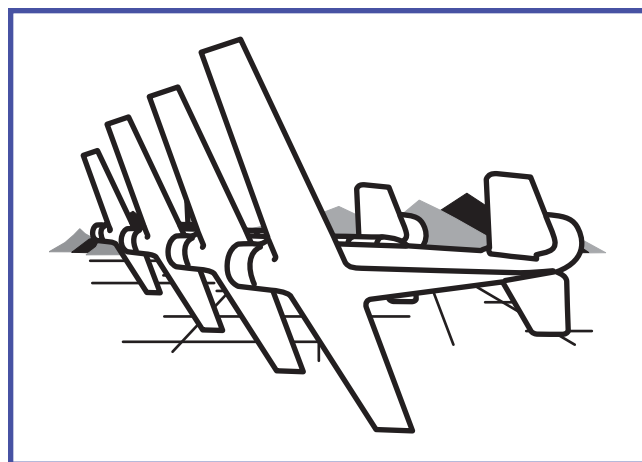

**Figure 5.12 Echelon**

When reconfiguring from echelon to finger four, move number two over using hand or aircraft signals as covered in section 5.5.3.

**CAUTION**

During training, when reconfiguring from echelon to finger four, move number two over using hand or aircraft signals. Avoid attempting to cross-under the second element using hand signals relayed by number two.

**Wingmen**

All flight members will match Flight Lead’s roll rate and limit fluctuations in G. During four ship echelon turns, three flies off of two and four flies off of three.

**5.5.5 Close Trail**

Four-ship close trail procedures and parameters are the same as two-ship with each aircraft flying reference off the preceding aircraft, with adequate stack down and approxi

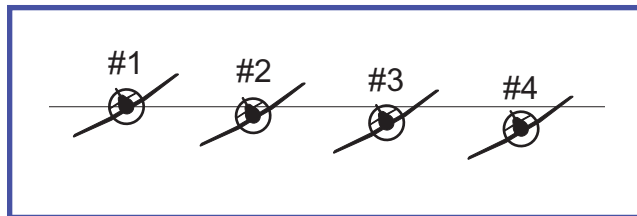

**Figure 5.13 Echelon**

mately one ship length nose to tail separation.

The Flight Lead will configure the flight in to close trail using a radio call or hand signal in accordance with appendix A. An alternate aircraft signal (porpoise of the nose) may be used if briefed before flight. For initial FAST qualification, use up to 45 degrees of bank and 20 degrees of pitch while maneuvering in close trail.

**Flight Lead**

Configure the flight to close trail from fingertip. If using a radio call, transmit, “Raven flight, go close trail”. If using hand signals in accordance with appendix A, provide the signal first to number two, and then to number three (reference figure 5.14). Begin maneuvering when number four reports in position.

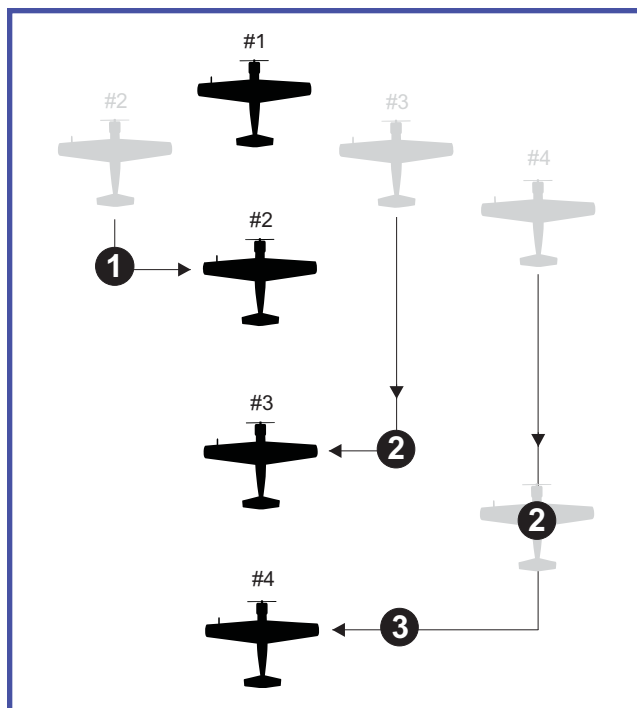

**Figure 5.14 Finger Four to Close Trail**

**Wingmen**

Acknowledge Flight Lead’s directive to close trail (radio call or head nod). Unless briefed otherwise, only number four must report in position with full call sign (“Raven four is in”). Follow all applicable procedures as covered in two ship formation. When Flight Lead directs the flight back in to fingertip with a wing rock, take up your former finger



**Image 5.3 Close Trail Formation**

four position.

### 5.5.6 Diamond

The diamond formation is a common element of our mass formations and a very maneuverable configuration. The Flight Lead will configure the formation in diamond using a radio call or hand signal in accordance with appendix A. For initial FAST qualification, use up to 45 degrees of bank while maneuvering in diamond.

The Flight Lead will signal for a return to fingertip configuration with a wing rock; at that time move back to your finger four position.

#### Flight Lead

Configure the flight for diamond from fingertip. If using a radio call, transmit “Raven flight go diamond”. If using hand signals, pass the signal to number three, who will in turn pass it to number four. Once number four has reported in position, smoothly begin maneuvering as required.



**Image 5.4 Diamond Formation**

#### Two

In diamond, strictly maintain fingertip position and sightlines at all times. Avoid flying low and/or sucked as you may encroach on number fours position in the slot.

#### Three

When given the signal for diamond, pass it to number four, but do not look at your Wingman for acknowledgment. Strictly maintain fingertip position and sightlines at all

times. Avoid flying low and/or sucked as you may encroach on number fours position in the slot.

#### Four

When three passes you the hand signal for diamond, move to the close trail position, approximately one ship length aft and slightly below the flight leader, and call in position with full call sign. Follow basic two ship close trail position keeping procedures and remain aware of number two and three at all times. Do not hesitate to move aft if your position is being encroached upon by either Wingman.

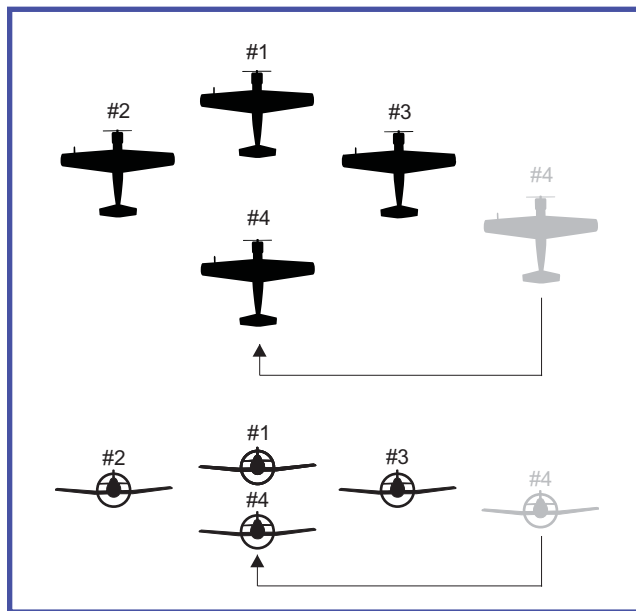

**Figure 5.15 Finger Four to Diamond**

### 5.5.7 Fingertip Formation Exercise: Wing Work

It is particularly important for Flight Lead to be aware of the necessity of smooth, coordinated aircraft control because, in a four-ship formation, Flight Lead’s flight control inputs, and resultant Wingman corrections, are generally magnified for number 4, and can result in a “crack-the-whip” effect. The Flight Lead will strive to maintain a constant power setting and plan maneuvers to maintain energy and maneuvering airspeed at all times.

#### Flight Lead

Monitor the Wingmen to make sure they are in a position to execute before you initiate a maneuver. Start with a “warm-up exercise” using shallow angles of bank before increasing bank angle and G-loads. Continue the exercise using modified lazy-eight maneuvers to vary airspeed, attitude, and G-load. Proficient FAST Wingmen will be able to maintain station-keeping throughout 45° of bank in either direction combined with ±20° of pitch change.

#### Wingmen

Refer to chapter two for basic guidance for maneuvering in fingertip. If unable to maintain position call Terminate, KIO or break out as the situation warrants.

## 5.6 Three-Ship Formations

There are two basic configurations for flying three-ship formation—the “Phantom Four” and the “Phantom Two.” The term “phantom” is used to signify that the flight will mimic procedures, parameters and/or maneuvers as if their were an aircraft in those positions.

The flight Flight Lead will determine which configuration is suitable to the mission or training objectives and brief the flight accordingly. While the Phantom Four is commonly used for airshows, the Phantom Two formation is effective for providing Wingman training in the number 4 position when the flight is limited to three aircraft.

### 5.6.1 Phantom Four

Phantom Four, commonly known as “Vic Formation” is a standard demonstration and enroute formation. The Vic is so named because it resembles the inverted letter V. Flight Lead is flanked on either side by number 2 and number 3. No special procedures are involved with Phantom Four except for the use of hand signals; the Flight Lead will treat number three as a complete element for signaling cross-unders.

### 5.6.2 Phantom Two

The Phantom Two formation is flown as if number 2 were present in the flight. Number 3 and number 4 will be positioned as an element on Flight Lead’s right or left wing. See figure 5.15.

The Phantom Two formation is useful for training purposes as it allows the wing pilot to practice second element departures, rejoins, cross-unders and wing work in the number 4 position with only three aircraft. (Figure 5.16).

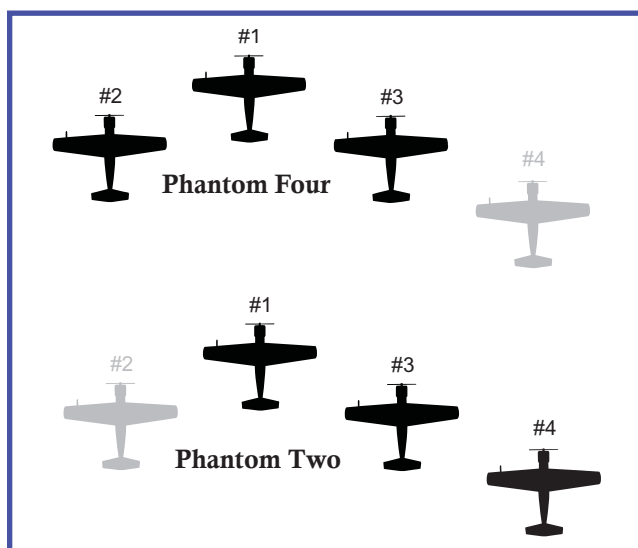

Figure 5.16 Phantom Four (vic) & Phantom Two

## 5.7 Formation Rejoins

This section will cover all four and three ship rejoins, turning and straight ahead, as well as overshoots.

### 5.7.1 Four Ship Turning Rejoins

During three and four-ship turning rejoins, Wingmen will relay the wing-rocking signal to the aircraft behind them.

#### Flight Lead

Normally, use a 5 second rejoin interval during qualification training. Observe each flight members progress and be directive if a safety of flight issue develops at anytime.

#### Two

In the absence of other instructions, number 2 will always join to the inside of Flight Lead’s turn and all procedures in chapter three are applicable. If number 2 is slow to rejoin, it will complicate the rejoin for number 3 and 4, who will have to decrease airspeed and/or cutoff to maintain proper spacing on the preceding aircraft. We always join “by the numbers,” in numerical order. Joining aircraft will not close to less than two to four ship-widths until the preceding aircraft is stabilized in route.

#### Three

You will join to the outside of Flight Lead’s turn. The basic rejoin techniques are the same as those flown by number 2 except that you have the additional responsibility of monitoring number 2 and being aware of number 4.

You should establish an aspect angle no greater than that used by number 2. Accelerate to gain an airspeed advantage on Lead (up to 10% above briefed rejoin airspeed) and maintain two to four ship-width spacing (minimum) on the Lead element until number 2 is stabilized in route. You should plan the rejoin to pass with a minimum of nose/tail separation behind and below the Lead element as you move to the outside of the turn, stabilizing in route, and deliberately moving into fingertip position on Lead. Avoid abrupt control pressure and rapid throttle movements in consideration of number 4.

#### Four

You will also always join to the outside of Lead’s turn, and basic rejoin techniques apply. However, you must monitor number 3 as well as the Lead element during the rejoin, anticipating number 3’s power reductions and movements.

On roll out in trail, you may likely be outside number one’s turn circle when he/she commences the rejoin. Recall from chapter three that to successfully rejoin, you must be inside the target aircraft’s turn circle and aft of his/her 3/9 line. One technique to help accomplish this is when you observe the Flight Lead turning to initiate the rejoin, delay your turn until number three has turned and moved across your canopy. This serves two purposes; it allows you to drive forward in to number ones turn circle, and insures your aspect on number three is not excessive during the rendezvous procedure.

Accelerate to gain airspeed advantage (up to 10% above briefed rejoin airspeed) and maintain two to four ship-

width spacing on number 3 until he/she has stabilized in route. Maintain this aspect angle on the Lead element and number 3, and plan your rejoin to pass with a minimum of nose/tail separation behind and below the first element and number 3 as you move to the outside of the turn. Stabilize in route and deliberately move into fingertip position on number 3. You must monitor all aircraft in the formation as the rejoin progresses.

### 5.7.2 Three-Ship Turning Rejoins

Procedures will differ slightly based on using Phantom Two or Phantom Four configurations.

- When flying phantom two turning rejoins, Wingmen follow second element (number 3 and 4) procedures, joining to the outside of Flight Lead.
- When flying phantom four (Vic) formation, number 2 and 3 will use the standard four-ship procedures: number 2 will join to the inside and number 3 will join to the outside.

### 5.7.3 Turning Rejoin Overshoots

Basic overshoot procedures covered in chapter three apply equally to three/four ship formation. As a member of a three or four-ship formation, you must recognize an overshoot situation as soon as possible and make positive corrections. If an overshoot is appropriate, follow procedures outlined in chapter three. In addition, the following considerations apply, based on your position in the formation:

#### Flight Lead

Monitor overshoots carefully and do not hesitate to direct a break-out if the situation warrants such a call. If a break-out does occur, be directive in stabilizing the situation and establishing a plan to get the flight back together using applicable KIO and blind-visual procedures as covered in chapter one.

#### Two

Announce your overshoot to alert number 3 that you are encroaching on his/her side of the Flight Lead, "Raven 2, overshooting." Clear to ensure sufficient spacing on number 3 before returning to the inside of the turn and completing the rejoin.

#### WARNING

During an overshoot by number 2, the second element will use extreme caution and allow sufficient room (minimum 100 feet) on the inside of the turn to allow 2 to maneuver back in to position before completing their rejoin.

#### Three

If number 2 overshoots, modify your rejoin by decreasing your airspeed and adjusting your pursuit option to ensure adequate clearance for number 2 to return to the inside of

Lead's turn. If you extend the speed brake or remain at idle power to rapidly bleed your airspeed, notify number 4, "Raven 3, idle or speed brake."

#### Four

Follow number 3 whether number 3 is overshooting or adjusting for a number 2 overshoot. If number 3 is overshooting, use good judgment and a combination of trail and rejoin techniques to stay with number 3. Maintain two to four ship-width clearance (minimum) until number 3 is stabilized in route. Depending how number 2 and number 3 fly the rejoin, for energy conservation or safety reasons, some situations may dictate that you fall into the six-o'clock position behind number 3. This position is the safest of all options, allowing you to conserve energy and maintain a visual on all members of the flight.

### 5.7.4 Straight-Ahead Rejoins

Straight ahead rejoins in four-ship employ the same procedures as in two-ship. Number 3 and number 4 will close no nearer than two to four ship-widths to the preceding aircraft until that aircraft is stabilized in route position.

#### Flight Lead

After completing the pitchout, signal for a rejoin by rocking your wings or making a radio call. Maintain the briefed rejoin airspeed. Monitor the Wingmen altitude, aspect, and closure as they come into your field of vision. Do not hesitate to take appropriate action if a dangerous situation develops.

#### Two

Pass along the wing-rocking signal to the aircraft behind you. Rejoin to the left side unless otherwise directed.

#### Three

Pass along the wing rocking signal to the aircraft behind you. Always join to the side opposite of number 2, on the Flight Lead's wing, and maintain a minimum of two to four ship-widths clearance on number 2 until number 2 is stabilized in route.

#### Four

Always join to the side opposite of number 2, on number 3's wing, and maintain a minimum of two to four ship-widths clearance on number 3 until number 3 is stabilized in route.

### 5.7.5 Straight-Ahead Rejoin Overshoots

Follow over-shoot procedures described for two-ship formation (chapter three) except that aircraft trailing the overshoot aircraft will not close nearer than 100 feet to any aircraft ahead until the aircraft in sequence ahead is stabilized in route position.

## 5.8 Breakout

Leaving formation is the same in three- and four-ship formations as in two-ship formations. However, if number 3



Fingertip Option A

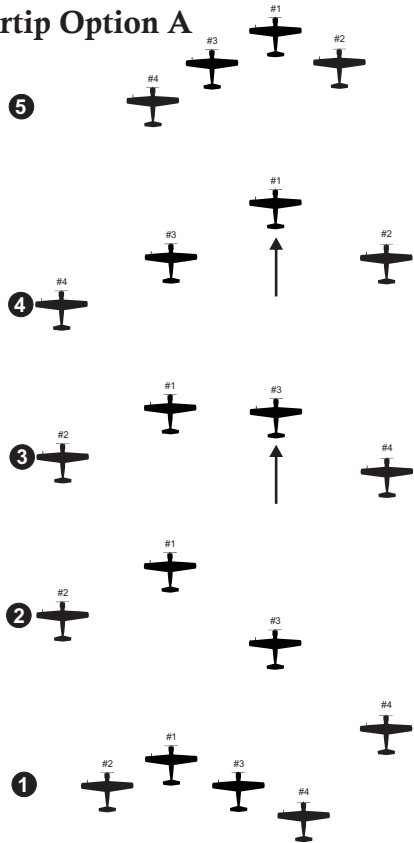

Fingertip Option B

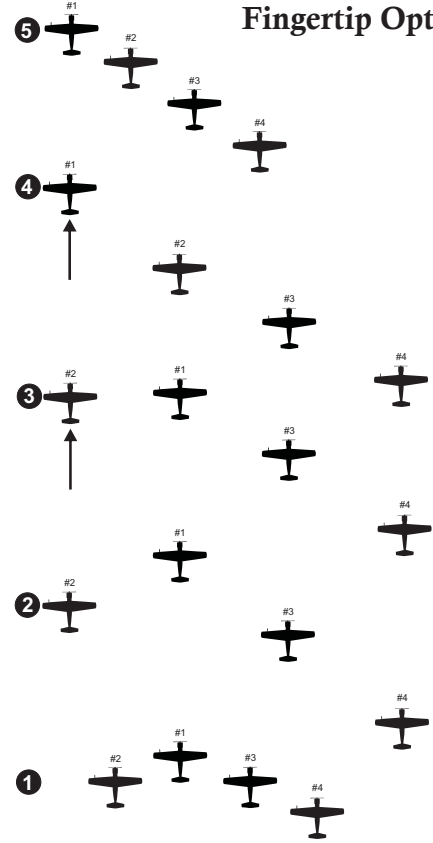

Echelon Option A

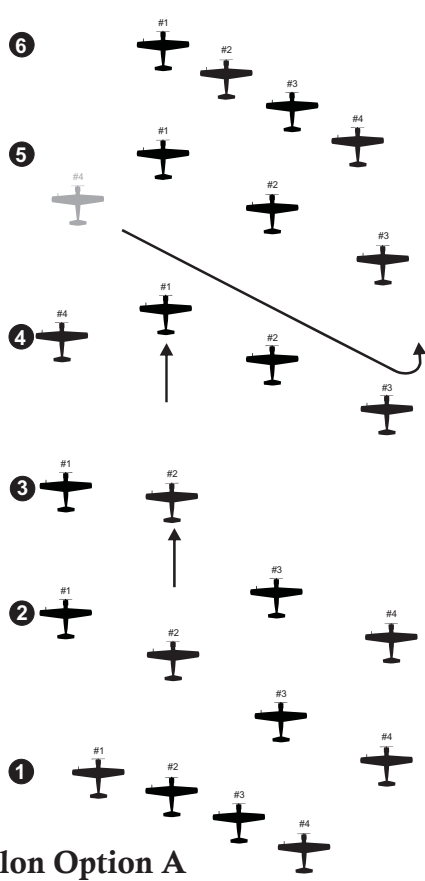

Echelon Option B

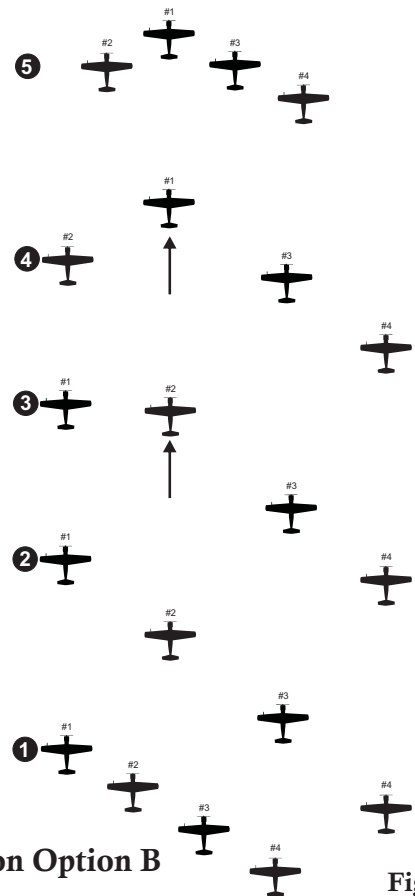

Figure 5.17

leaves the formation, number 4 will follow number 3 at a safe distance to maintain element integrity if safe to do so.

In all cases, the Flight Lead will provide adequate altitude separation and direct the rejoin as required. An aircraft that has left formation will not rejoin until cleared to do so.

### 5.9 In Trail (Tail Chase)

Unlike Extended Trail, “In-Trail” is a maneuver formation allowing the flight to line up one behind the other with an interval briefed by the Flight Lead. This may be required to prepare for individual VFR pattern entry and landings or as needed.

Use power and pursuit curves as needed to maintain interval - no offset is required or expected.

#### Flight Lead

Insure you brief the desired In-Trail interval. Enter In-Trail from fingertip, close trail or Extended trail. Use a radio call to send the flight to In Trail:

Raven Flight, Go In-Trail, 200 feet

Use a radio call or standard visual signals to reform the flight to fingertip. You may use a straight ahead or turning rejoin to reform the flight.

#### Wingmen

When instructed to reform to In-Trail, maintain visual on your Flight Lead/reference aircraft at all times. Acknowledge the call with full call sign.

The In-Trail position is directly astern of your Flight Lead/reference aircraft. Interval is principally maintained through the use of power, although if needed, use minor lead and lag to correct interval as the Flight Lead maneuvers the formation. Generally stack down slightly unless briefed otherwise.

If the Flight Lead uses a wing rock to reform the flight, mirror the signal to the aircraft behind you. Rejoin to your previous position unless briefed otherwise.

### 5.10 Deleted

### 5.11 In-Flight Lead/Position Changes

Temporary position changes are often required to provide training for both the Flight Lead and Wingman qualifications, as well as adapting to real world conditions (degraded navigation and/or communication capability, etc.).

If not required specifically for training, the lead position will normally pass to number three while in fingertip route formation as detailed below. Position changes may be executed from route fingertip or route echelon. Lead must

thoroughly brief the planned procedures. See page 5-13.

#### 5.11.1 Lead Changes From Fingertip

After the formation is stable in the route position, if using the radios, Lead will announce the lead change by stating: “Raven 2/3 you have the Lead (on the left/right).” The new Lead will acknowledge by stating: “Raven 2/3” . The new Lead will move to the line abreast position and then call “Raven 2/3 has the Lead (on the left/right),” while slowly moving forward. The Lead change is now complete and the now former Flight Lead will take up his/her position as number three.

If using hand signals, once established in route formation, Lead will point at the Wingman who will assume the Flight Lead position, and then point forward repeatedly. The Wingman will acknowledge with ahead nod. The Wingman will then move line abreast and indicate “I have the Lead” by tapping on his/her forehead and pointing forward. The Lead change is now complete and the former flight Lead will take up his/her new Wingman position. In fingertip, the original Flight Lead also has the option of passing the Lead to number two using the same procedures above, see figure 5.13.

#### 5.11.2 Flight Lead Changes From Echelon

During position changes from route echelon, Lead may take up the number two or four position as briefed. When the original Flight Lead becomes number two, the original number two assumes the new Flight Lead using the procedures detailed above and the second element retains their positions.

If the original Flight Lead assumes the number four position, he/she will, after passing the Flight Lead to number two, drop back and execute a cross-under to the number four position.

The original four becomes three, and three becomes two. The other aircraft in the flight will remain stable until the new Leader has pulled forward to the point at which they can pick up the normal sightline references. When the new formation is stable, the new Flight Lead will check the flight in to confirm the new formation positions: “Raven check, Raven 1.” Once the flight has checked in properly, Lead will reform the formation to fingertip, and begin the briefed maneuvers.

#### 5.11.3 Three-Ship Flight Lead Change

During lead changes from fingertip, Number 3 will move forward (as in a four-ship element lead change) to become Number 1, original Number 1 will become Number 2, and Number 2 will become Number 3. After the lead change, the formation is in echelon position.

**NOTE**  
After all lead changes, the new leader will check-in the flight to confirm new position numbers.

### 5.12 Formation Recovery and Landings

All applicable two ship landing procedures apply to three and four ship formations. Review chapter one, section 1.2.3 for additional safety guidance.

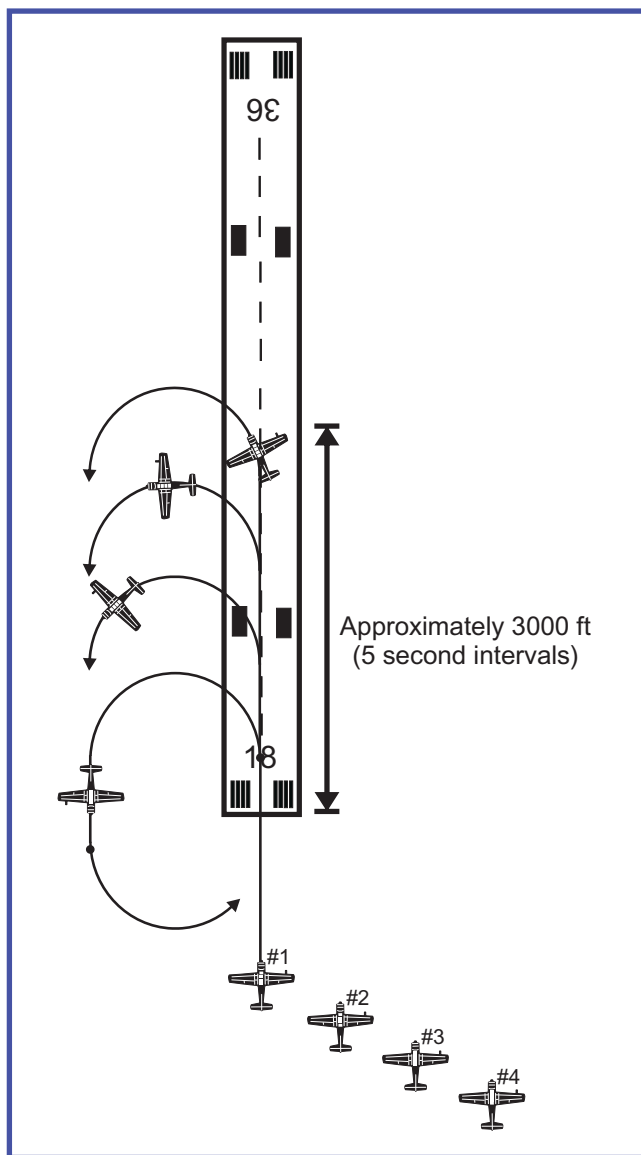

**Figure 5.18 Four Ship Overhead**

#### 5.12.1 Overhead Pattern

The overhead pattern procedures are identical to those covered in your two ship guidance. Flight Leads should brief either the “hot-cold” or “staggered” landing procedure to be used if the runway width is adequate.

##### 5.12.1.1 Establishing Proper Interval

Using a five second pitchout, wingmen will have the ap-

proximate minimum landing interval on roll out and may use a common perch point, see figure 5.18.



**Image 5.5 Three Ship on Initial**

If using the fan break, or pitchout intervals shorter than five seconds, proper interval can be obtained by wingmen delaying the perch point (base turn) as needed to gain proper spacing.

**INSTRUCTORS' NOTE**  
Instruct the wingman to offset *slightly* outside the track of the preceding aircraft on inside downwind, this will keep him/her out of prop/jet wash and aid you in maintaining visual.

All like-aircraft should maintain the same briefed approach speed to assist in maintaining relative position in the pattern.

**Flight Lead**

Always strive to be on airspeed-on altitude, with proper runway displacement when leading the overhead recovery. In doing so you will assist your wingmen as well. Lead pilots will normally land on the side of intended ramp exit if runway width and conditions allow. Take a normal to slightly long aim point based on runway available and aircraft following. Avoid low, dragged-in final approaches

as this will often be mirrored by trailing aircraft. Tailwheel aircraft decelerate rapidly in a three point configuration and often may take a longer aimpoint. However, never compromise runway available for landing and roll out in doing so.

Upon touchdown, do not rush to decelerate on landing unless required for safety. Brief and use an exit point near the end of the runway to allow all wingmen ample space to decelerate to taxi speed without the need for excessive braking. If a problem arises during landing and roll out that may impact the safety of your wingmen, alert them as soon as you are able to do so.

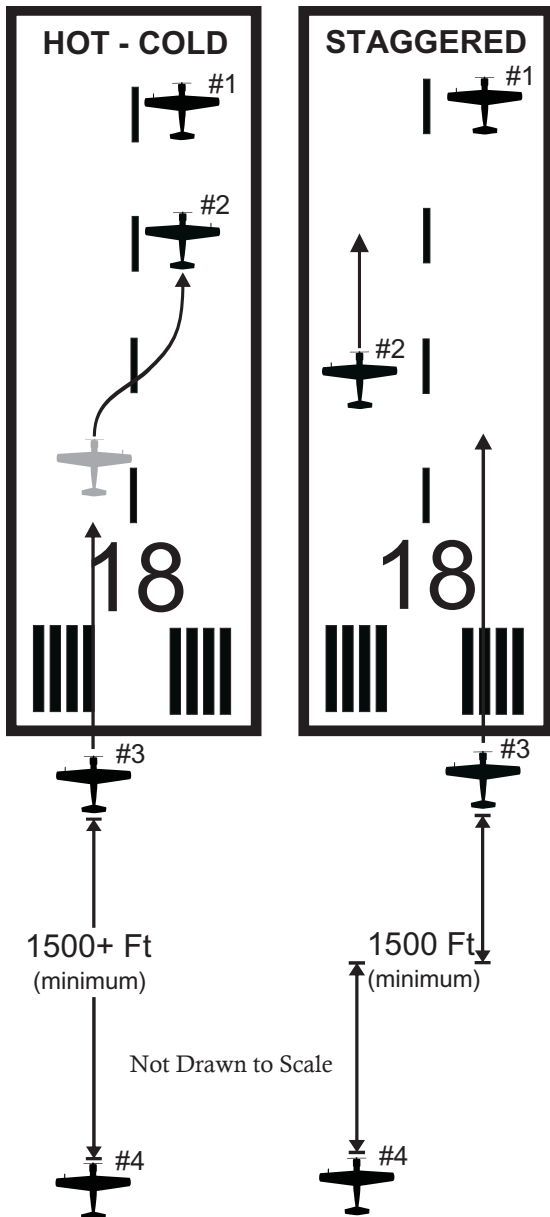

Figure 5.19 Hot-Cold and Staggered Landings: Prop

**Wingmen**

Fly on airspeed and on altitude during the overhead approach; a poorly flown pattern will often impact trailing aircraft. While a smartly flown pitchout is impressive to the audience, equally impressive is the skill required in flying equal pattern/landing intervals.

Use no less than the recommended minimum threshold crossing intervals provided in chapter one and represented in figure 5.19 when using either the Hot Cold or Staggered landing procedure as briefed. If your threshold crossing interval becomes compressed on final, or if your runway lane is otherwise occupied by a preceding aircraft such that safety is in question, simply execute a go around/low approach and enter the VFR pattern.

If using Staggered procedures, recall that during a normal four ship landing, all wingman landing on the side of intended ramp exit must clear the preceding aircraft to cross the runway centerline when it is safe to do so (i.e. “Raven 2 is cleared to cross”).

**WARNING**

A member of the flight experiencing difficulty during landing and roll out, such as blown tires, brake fade/failure, etc., will notify the flight as soon as possible with intentions if able, “Raven 2 is hot side - no brakes”

**5.13 Summary**

Four ship is the culmination of your basic formation training and opens the door to participation in larger “mass” formation demonstrations. However, before making that progression, let’s look at abnormal procedures in chapter six.

## CHAPTER SIX

### Abnormal Operating Procedures

#### 6.1 Introduction

This chapter includes techniques to provide direction in an abnormal situation. The intent is not to cover every situation a pilot may encounter. It is not intended to replace or supersede procedures in the Aircraft's Operating Handbook, manufacturers procedural guidance, or sound judgment.

Your flight-mates are ready to provide support, but do not allow radio communications or other aircraft distract you from the primary responsibility of flying the aircraft. Do not hesitate to direct others to standby until able to safely provide the requested information. When making radio transmissions, be clear, concise and emphasize exactly what assistance you need.

#### 6.2 Ground Aborts

When a flight member aborts prior to takeoff, the flight lead will normally realign flight positions to maintain a numerical call sign sequence.

#### 6.3 Takeoff Aborts in Formation

As covered in chapter 2, formation takeoffs are conducted using "element" or "Interval" procedures. The element takeoff is executed in close formation from brake release with a minimum of ten feet of wingtip clearance, while interval takeoffs are conducted single-ship with a rejoin soon after airborne. A successful takeoff abort, whether interval or element, requires accurate and prompt execution of procedures detailed below. The aborting aircraft (or element as the case may be) must maintain aircraft control, ensure separation from other aircraft and communicate their actions using the radio as soon as practical.

If the flight is made up of multiple elements using timed interval takeoff procedures (see chapter 5), prompt recognition, action and communication of an aborted takeoff is essential to prevent the possibility of aircraft collision.

##### 6.3.1 Element Takeoff Aborts

###### 6.3.1.1 Individual Aircraft Abort Procedures

Normally, during a formation element takeoff, there will be no sympathetic aborts by Wingman or Lead within the element after brake release. This means if one member of the element must abort the takeoff, the other flight member will continue if safe to do so. Sympathetic aborts can create situations where the good aircraft is aborting with an emergency aircraft and risking hot brakes, blown tires, loss of directional control, and other unforeseen complications.

During a takeoff abort by Lead or Wing, the other aircraft will select max/takeoff power and execute a normal single-

ship takeoff and maintain his/her side of the runway if safe to do so. In this situation, the aborting aircraft will transmit, "Raven [flight position number] is aborting" and maintain their side of the runway.

###### 6.3.1.2 Dual Aircraft (Element) Abort Procedures

If both aircraft in the element must abort, due to such conditions as a fouled runway or runway incursion, lead should transmit, "Raven Flight, ABORT, ABORT, ABORT"

Lead may also make a directive call, "Raven 2 ABORT NOW" if the wingman appears to be continuing the takeoff after an element abort is called. Both aircraft must maintain their respective side of the runway.

###### 6.3.1.3 Trailing Element Abort procedures

In four ship or mass formation, if the trailing (following) element has not released brakes when an abort is recognized or communicated, they will hold position. If they have released brakes using timed interval procedures (see chapter 5), they will normally execute an immediate element abort.

##### 6.3.2 Interval Takeoff Aborts

Use the following procedures in the case of an interval takeoff abort. Interval takeoffs are normally conducted for training, or when runway width, crosswinds or ATC restrictions prevent an element takeoff. A "staggered" interval takeoff allows each aircraft to maintain their respective side of the runway from brake release through lift off.

#### CAUTION

Staggered interval using timed brake release procedures assume the runway width allows a clear lane for both aircraft in motion with a minimum of ten feet wingtip clearance; for most RPA aircraft, this requires a runway width of 100 feet or greater.

The aborting aircraft will transmit "Raven X aborting", and if on the centerline, attempt to move to the cold side of the runway if runway width and aircraft control allow, but do not sacrifice safety to do so. The cold side is nearest the normal runway exit path for landing/aborting aircraft.

If the aircraft are conducting staggered interval takeoffs (i.e. maintaining opposite sides of the runway throughout the takeoff roll), aborting aircraft, if safe to do so, will maintain their side of the runway during the abort.

###### 6.3.2.1 Trailing Interval Aircraft Abort Procedures

If the preceding aircraft aborts after the trailing (following) aircraft has already released brakes using timed interval procedures (see chapter 5), he/she will abort if safe to do so. If there is a clear lane to continue the takeoff, the following aircraft may choose to continue if it is the safest course of action. If using “lift off” interval procedures, hold position and wait for preceding aircraft to clear the runway.

## 6.4 Airborne Emergencies

As much as possible, maintain element formation integrity for all airborne emergencies. However, should a pilot of an aircraft experience engine/power problems in close proximity to a landing field, such as immediately after takeoff, do not delay recovering the aircraft due to formation considerations. In these situations, announce your intentions over the radio.

If any aircraft malfunction occurs while in close (parade) formation, ensure aircraft separation before handling the

### NOTE

See section 6.9 for specific emergency chase formation procedures.

emergency. The pilot of an aircraft experiencing an abnormal situation will advise the flight lead of the problem, intentions, and assistance required.

### Lead

If possible, move the flight to route formation first, then deal with the malfunction. If the pilot with the malfunction can transmit and navigate, offer him/her the lead so you can fly support. There are some emergencies, such as simple radio failure or pitot/static failure where you should retain the lead. Attempt to follow the formation briefing instructions for contingencies, if applicable, so the wingman knows what to expect.

### Wing

When an aircraft malfunction or emergency occurs, call “Knock It Off” and inform lead of the problem. Normally, if you are able to communicate with outside agencies and navigate, take the lead when offered. As much as possible, avoid flying the wing position with an emergency. If you must fly the wing position, fly no closer than route formation.

## 6.5 Radio Failure

If an aircraft experiences a partial or total radio failure (NORDO), defined as the inability to transmit and/or receive, the flight should be terminated as soon as practical and the no-radios (NORDO) aircraft will assume or retain the wing position and be led back to the field of intended landing, or divert as briefed.

### 6.5.1 Recovering a NORDO aircraft

A formation approach to a drop-off on final should be performed unless safety, pilot qualification, weather or other considerations dictate otherwise. The lead pilot should inform the tower or applicable controlling agency and coordinate the go-around. Once the flight is established on final with landing clearance received, the lead pilot will give the distressed pilot the “you’ve got the lead” hand signal after he/she has obtained clearance to land if able. The support pilot will then execute a single-ship go-around. In most cases the support pilot will accomplish the drop off at or above 300 feet AGL. The formation drop-off procedures will ensure the NORDO aircraft has clearance to land from the tower or other controlling agency.

If the flight recovers to the overhead pattern, once the aircraft separate at the break, the NORDO pilot must be cognizant of tower-directed light signals for landing clearance IAW the Airman’s Information Manual or host nation procedures.

### CAUTION

The NORDO aircraft must always be alert for tower-directed light signals. Regardless of which method of recovery is used.

### 6.5.2 Radio Failure as Lead

Send the wingmen to route and give the appropriate visual signal IAW appendix C, then pass the lead to either #3 or #2, as appropriate.

### 6.5.3 Radio Failure as Wing

While in close or route formation, maneuver within close/route parameters to attract the attention of the flight or element lead and rock your wings IAW appendix C to alert the flight/element lead you require assistance. If flying in any other formation, such as extended trail, approach your flight/element lead, but do not rejoin closer than two to four ship-widths. Rock your wings to gain your flight or element lead’s attention and wait for him/her to pass the visual rejoin signal before proceeding. When signaled, rejoin and pass applicable NORDO visual signals IAW appendix C. Expect to be led back to the briefed recovery field following the procedures contained in this section.

### 6.5.4 HEFOE Signals

If you experience a radio failure AND another malfunction, such as a total electrical failure causing a NORDO condition, use “HEFOE” signals to communicate the particular system problem. “HEFOE” stands for:

1. Hydraulic
2. Electrical
3. Fuel
4. Oxygen

## 5. Engine

A HEFOE signal is given in two steps. After getting Lead's attention with the wing rock, using procedures listed in RADIO FAILURE section of this chapter, provide the flight lead with the HEFOE visual signal listed in appendix C followed by the number of fingers corresponding to the particular system problem.

### NOTE

Some aircraft use pneumatics in the place of hydraulics, so one finger is used in these aircraft to signify a pneumatic problem.

Expect to be offered the lead to accomplish emergency checklist duties. Pass the lead back when you are ready to recover for landing IAW with NORDO procedures.

## 6.6 Intercom Failure

Flight training in tandem seat aircraft produces the possibility of communication failure between instructor and pilot in command. Procedures must be in place to ensure aircraft control is positively determined at all times.

### 6.6.1 Preflight Briefing

When carrying a rear seat occupant, each PIC of a tandem seat aircraft should brief the procedure for transfer of aircraft control, emergency escape, and bailout/ejection procedures and signals to be used if verbal communication is impossible.

### 6.6.2 Transfer of Aircraft Control

Normally, with an operable intercom, transfer of aircraft control is prefaced with "I have the aircraft" followed by shaking of the stick. This is acknowledge by the other pilot announcing "You have the aircraft" and then relinquishing all controls.

Without intercom, transfer of aircraft control can result in disastrous crew confusion if not accomplished properly. If intercom failure occurs when the PIC is not flying the aircraft, the second pilot will continue to fly the aircraft until the PIC shakes the stick. At this time the second pilot will relinquish all controls and hold up his/her hands (backseat occupants may be viewed with mirrors, if equipped).

Under normal circumstances, the PIC will retain control through the remainder of the flight. However, some circumstances may necessitate a subsequent transfer of control (emergency checklist duties, complications due to front canopy penetration from bird strike, etc.). In these circumstances, the flying pilot will yaw the aircraft with the rudders when desiring to pass control back to the other pilot.

This is required as the second pilot may not have his/her hands on the stick to receive the standard stick-shake signal. The second pilot will then acknowledge by shaking the stick and looking for the PIC to show hands clear.

## 6.7 Lost Wingman Procedures

The objective of Lost Wingman procedures is to gain immediate separation of aircraft when any Wingman loses sight of his/her Leader in Instrument Meteorological Conditions (IMC), whether inadvertent or intentional. Lost Wingman procedures may also be applicable to rare situations of Wingman experiencing severe spatial disorientation.

### WARNING

Operating in less than VMC requires training and certification beyond the scope of this manual. Flight in to IMC, or marginal VMC, conditions may result in spatial disorientation, loss of aircraft control and/or mid-air collision.

### Wing

In any Lost Wingman situation, immediate separation is essential. On losing sight of the leader, or if unable to safely maintain position due to spatial disorientation, simultaneously execute the applicable Lost Wingman procedure detailed below while transitioning to instruments. Smooth application of control inputs is imperative to minimize the effects of spatial disorientation.

The execution of Lost Wingman by one flight member *does not* require the execution of Lost Wingman procedures by all flight members; if you can safely maintain the parade formation position, continue to do so if it is the safest course of action.

### Lead

If faced with deteriorating conditions in formation, the Flight Leader should consider reversing course, landing at the nearest suitable alternate or establish a one mile trail formation with vertical separation while coordinating with Air Traffic Control for radar separation and other assistance.

If Lead unintentionally enters IMC, he/she will immediately transition to instruments and, if a turn is required, make a shallow angle of bank turn of 15 degrees for 180 degrees away from the wingman to attempt to return to VMC. The Wingmen will maintain the parade (fingertip) position references during all turns in IMC.

When informed a flight member is executing Lost Wingman, immediately follow applicable procedures, while transmit your current heading and altitude to aid in maintaining safe separation. When time permits, the Flight Lead

will coordinate with the controlling agency and requests a separate clearance for the Wingman as required. The controlling agency can help establish positive separation.

**WARNING**

The following procedures *do not* guarantee obstacle clearance along your flight path. Good judgment must be used when exercising these emergency procedures.

**6.7.1 Two or Three Ship Flight Procedures**

The following procedures are applicable for two or three ship formations. If flying in three ship echelon, the Flight Lead should re-form to fingertip (phantom four) if visibility is degraded. If number three must execute Lost Wingman while in echelon, follow four-ship Lost Wingman procedures.

**NOTE**

The times used in the following examples are predicated on an aircraft flying at 110 kts to establish approximately 30 degrees of heading change. For higher speeds see figure 6.1.

**6.7.1.1 Wings-Level Flight. (Climb, Descent, or Level)**

**Lead**

Upon notification of a Lost Wingman, acknowledge the call and continue straight ahead and provide current heading and altitude (if level). If climbing or descending, report altitudes every 500 - 1000 feet as desired.

**Wing**

The Lost Wingman will simultaneously transition to instruments, turn away, using 15° of bank for 10 seconds. This will produce approximately 30 degrees of heading change at 100-120 knots. Inform Number 1, “Raven X is Lost Wingman”. Wingman may obtain a separate clearance as required. Resume course only after vertical separation is assured.

As previously mentioned, the initiation of Lost Wingman procedures by one aircraft *does not* require a reciprocal reaction by all flight members; if safe to do so, with lead in site, remain in the parade (fingertip) position.

**6.7.1.2 Turns. (Climb, Descent, or Level)**

**Lead**

Acknowledge the call while maintaining current angle of bank and provide heading and altitude information as needed to assist the Wingman. If requested to roll out, call the roll out heading and only resume the turn once separation

is assured.

**Wing**

If you have lost site of the Flight Lead, follow the applicable procedure:

- **OUTSIDE THE TURN:**

Reverse the direction of turn using 15 degrees of bank for 10 seconds while inform the leader you are executing Lost Wingman procedures. Inform the Lead of your heading when able. Ensure separation prior to resuming the turn. Obtain a separate clearance if required.

- **INSIDE THE TURN:**

Momentarily reduce power to ensure nose-tail separation, and inform the flight leader to roll out of the turn. Maintain current angle of bank to ensure lateral separation. Inform the Lead of your heading when able. Once assured of separation, the leader may resume turn. Obtain separate clearance if required.

As previously mentioned, the initiation of Lost Wingman procedures by one aircraft does not require a reciprocal reaction by all flight members; if safe to do so, with lead in site, remain in the parade (fingertip) position.

Airspeed	15° AOB: Time to 30° of turn
100 kts	10 seconds
150 kts	15 seconds
200 kts	20 seconds
250 kts	25 seconds

**Figure 6.1 Times for Various Airspeeds**

**6.7.2 Four Ship Flight Procedures**

If executing Lost Wingman in four ship, number 2 and/or 3 will follow the procedures outlined in section 6.7. Number four will follow procedures listed below. Lead should reform any three or four ship echelon in to fingertip if visibility/flight conditions are of a concern.

Since it is impossible for number 4 to immediately ascertain that number 3 still has visual contact with the leader, it is imperative that number 4’s initial action be based on the assumption that number 3 has also become separated, and the following procedures are executed promptly.

**6.7.2.1 Wings-Level Flight. (Climb, Descent, or Level)**

Upon losing site of number three, number four will simultaneously transition to instruments, turn away using 30 degrees of bank for 15 seconds, inform the flight “Raven Four is Lost Wingman”. Inform Lead of your roll out heading and altitude when able. Obtain a separate clearance if required.



### 6.7.2.2 Turns.

#### (Climb, Descent, Level)

If either number two or three is Lost Wingman, they will follow applicable procedures contained in section 6.7.1.2. If number four is Lost Wingman, he/she will transition to instruments while simultaneously executing the applicable procedure listed below,

- **OUTSIDE THE TURN:**

Reverse direction of turn using 30 degrees of bank for 15 seconds to ensure separation from lead and number 3 and obtain separate clearance.

- **INSIDE THE TURN:**

Momentarily reduce power to ensure nose-tail separation and *increase* current bank angle by 15 degrees. Inform the leader to roll out. Obtain separate clearance. Leader will resume turn only when separation is ensured.

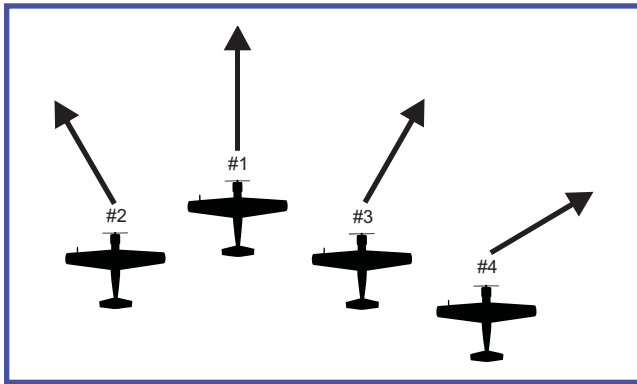

**Figure 6.2 Lost Wingman: Four Ship**

In either case, provide the Leader with your roll out heading and altitude after executing Lost Wingman.

### 6.7.3 Practicing Lost Wingman Procedures

Lost Wingman procedures may be practiced in VMC conditions to prepare wingmen for actual situations they may encounter. The flight lead assumes all responsibility for aircraft separation only in two ship. For this reason, when executing Practice Lost Wingmen in three or four ship, an Instructor Pilot (IP) should be onboard the wingman's aircraft for safety. For training purposes, if briefed, Lead directs practice Lost Wingman for all aircraft with the following call radio call.

“Raven Flight, go practice Lost Wingman”

At this time the wingmen transition to instruments while simultaneously executing the appropriate procedure and transmitting in sequence,

“Raven (position number) is practice Lost Wingman”

The Flight Lead and/or Wingmen will transmit all appropriate calls IAW this chapter for the applicable procedure.

The IP in the wingman aircraft will monitor aircraft separation throughout the maneuver and request “terminate” when learning objectives have been met. The flight lead will direct a rejoin as required.

#### WARNING

Non-instrument rated pilots should use good judgment when executing flight with reference to instruments. In general, restrict bank angles to no more than 30 degrees and pitch angles to no more than 10 degrees unless the emergency situation demands otherwise.

## 6.8 Spatial Disorientation

The most common form of spatial disorientation is known as “the leans.” It is a condition often associated with operating an aircraft with little or no discernible horizon. The leans can occur during formation flight for a number of reasons to include illness, damage to the vestibular region of the inner ear, or environmental conditions. The following procedures will help deal with the rare episodes of extreme spatial disorientation while flying formation.

#### Lead

If your wingman informs you that he/she is experiencing spatial disorientation, cease maneuvering and establish straight and level flight while transmitting flight parameters—this may reduce the sensation of spatial disorientation. If spatial disorientation persists, consider passing the lead to the wingman if conditions permit. If in a flight of more than two aircraft, separate the flight into elements to more effectively handle a wingman with persistent spatial disorientation symptoms.

#### Wing

If you become spatially disorientated at any time, immediately inform Lead. Make every effort to maintain position if safe to do so. If unable to maintain safe formation position due to this condition, execute Lost Wingman procedures IAW this chapter and notify Lead.

## 6.9 Damaged or Abnormally Operating Aircraft Procedures

If a single aircraft is damaged, experiences severe over-G, has indications of an unsafe gear or develops other safety-related mechanical issues in flight, the pilot will immediately request the lead after following KIO/TERMINATE procedures IAW Chapter One. The other aircraft will fly chase formation and provide assistance and inspection as needed.

### 6.9.1 Mid-Air Collision

Lead will insure separation laterally and vertically. If part of a four-ship, the non-mishap aircraft will provide chase duties as outlined in section 6.9.2. Do not delay recovery

waiting on chase aircraft unless absolutely required for safe recovery.

**WARNING**

If both aircraft are damaged in a mid air, they will not fly chase for one another.

### 6.9.2 Chase Parameters

Chase formation is defined as maneuvering airspace up to 45° aspect angle either side of the emergency (lead) aircraft. Fly no closer in range than required to observe the mishap aircraft without becoming a distraction, or endangering your aircraft from Lead's abrupt maneuvering due to loss of control, structural failure, or unexpected bailout/ejection. Avoid flying directly behind the lead due to falling parts, bailout, etc.

#### Lead (Emergency Aircraft)

Once the lead change occurs, use your wingman as an asset to help deal with the situation. When immediate emergency action items are completed, delegate tasks to the wingman as appropriate. Your wingman can read checklists over the radio if available, confirm position of divert fields, direct navigation, conduct airborne damage inspections, etc. Attempt to follow your formation briefing instructions for contingencies if applicable so the wingman knows what to expect.

#### Wing (Chase Aircraft)

Fly the a proper formation chase position on Emergency Lead. Do not approach closer than route formation unless required for gear inspection or other observation assistance and requested by the emergency lead. Except for unusual circumstances, do not land in formation with a disabled aircraft, fly a low approach no lower than 300 feet AGL.

The best wingman during an emergency is one who flies a solid chase position from which to observe Lead's aircraft, monitors key safety issues such as bailout altitudes, and otherwise remains silent unless absolutely required or requested by Lead. "Over-helping" wingmans may distract Lead from performing critical steps in resolving his/her emergency.

**WARNING**

Do not fly close/parade formation unless absolutely required and coordinated with the emergency Lead for inspection (landing gear or aircraft damage, for example).

### 6.10 Bird Strike

Care must be taken not to cause a mid air collision attempting to avoid an imminent bird strike. If a bird strike does occur, gain separation before handling the emergency. The most critical conditions due to bird strike are engine or prop failure, airframe structural damage, or cockpit penetration. Consider being led back for a wing landing if forward visibility is severely restricted.

### 6.11 Bailout/Ejection

If the aircraft is unsafe for continued flight or landing, it may be necessary to execute a controlled bailout or ejection. If time permits, the pilot of the emergency aircraft will inform the flight/element lead who should ensure flight separation both laterally and vertically.

#### 6.11.1 Crew Considerations

If the aircraft has more than one occupant, and time permits, the bailout/ejection procedures should be reviewed. When ready, the pilot in command should call over the intercom: "BAIL OUT, BAIL OUT, BAIL OUT" or "EJECT, EJECT, EJECT" as applicable to the aircraft, as the execution command. Normally, the rear occupant goes first (some ejection systems control sequence).

**WARNING**

In critical situations, such as complete loss of aircraft control with insufficient altitude to recover or structural failure, if not Pilot In Command, do not delay an ejection/bailout waiting for the "BAILOUT" or "EJECT" command.

### 6.12 Search and Rescue (SAR)

When a formation member bails out, ejects or executes a forced landing, steps must be taken immediately to positively locate the downed aircrew and initiate rescue efforts. In many cases, the downed aircrew will suffer from shock or delayed reactions to bail out, ejection, or forced landing injuries—recovery time is critical. The following procedures are by no means complete, and may be adjusted to meet each unique situation.

**NOTE**

The flight lead should review basic SAR procedures during the formation briefing as applicable.

#### 6.12.1 Specific SAR Actions

The following are suggested actions that should be made to assist in the location and recovery of a downed pilot/aircrew.

**Respond**

Immediately terminate maneuvering using appropriate Knock-It-Off procedures. Establish a SAR commander—normally the flight lead. Remain above the last known/observed parachute altitude until position of all survivors is determined. De-conflict other aircraft and flight members assisting in the SAR effort by altitude to preclude mid-air collision. Establish high and low SAR covering air patrol orbits (“SARCAP”), if required, to help facilitate radio communications and coordination efforts.

**Squawk**

Squawk the emergency code to alert air traffic control.

**Talk**

Immediately communicate the emergency situation to the applicable air traffic control agency. Inform them of your intentions to provide airborne search and rescue support.

**Mark**

Mark the last known, or currently observed positions of the survivors or crash site using GPS or any other means available, such as radial/DME, ATC radar positioning or ground references. Communicate this information to ATC to assist in subsequent rescue efforts.

**Assess**

The flight lead should attempt to assess the survivors condition visually. This information should then be relayed to applicable controlling agencies/ATC to assist responding rescue assets.

**Bingo**

Revise bingo fuel and/or recovery bases as required to maintain SARCAP coverage over survivors and/or crash site. Do not overfly bingo fuel. Relinquish CAP operation to designated rescue forces upon their arrival. Such units may consist of helicopter-borne hospital units, county sheriff, EMS, Fire Department, etc.

**6.13 Summary**

This chapter was not intended to address every contingency situation, but to provide general guidelines to assist in the decision making process. The application of sound airmanship, judgement and leadership will ultimately determine the successful outcome of an emergency situation. Flight leads should brief applicable contingency and emergency response plans as appropriate to their flight.

## APPENDIX A

### Formation Visual Signals

#### Introduction:

Most signals will be provided by the Flight Lead. In some cases, he/she will provide a preparatory command before the command of execution; both are covered here. Where applicable. Wingman will normally acknowledge the preparatory command.

If required to relay a visual signal, such as signaling number four to diamond, the Wingman will not look away from the Flight Leader for wingman acknowledgment.

Flight Lead's should always brief non standard visual signals prior to their use. If flying with non RPA members, insure they are familiar with all visual signals.

#### Wingman Universal Acknowledgment

Nod head in response to hand signals that you are clear on the meaning, and can/will comply. If unclear, do nothing until signal is repeated.

#### Wingman Universal "OK"

To indicate that you are "ok and ready to proceed", the thumbs up signal can be used. Do not use the thumbs up to replace the head nod for in-flight signal acknowledgment, to include formation takeoff signals.

#### Start Engines:

Extend arm over head and make circular motion with hand.

#### Engine Run Up:

Make a circular motion with vertically extended index finger.

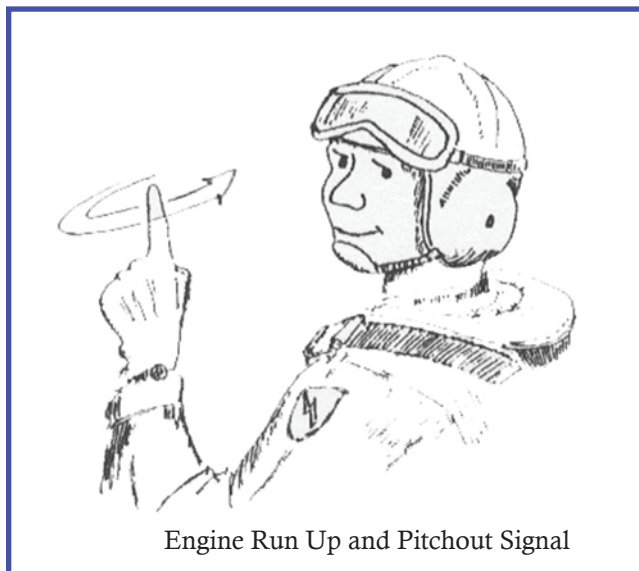

Engine Run Up and Pitchout Signal

#### Zero Altimeters:

Give the "OK" sign to wingman. Index and thumb touching.

#### Ready to take the runway for takeoff:

Provide a thumbs up to the Flight Lead

#### Ready for takeoff

Wingman looks at Flight Lead and nods head. All wingman acknowledgments to visual signals will be done with the head nod when on the runway/during flight.

#### Start takeoff roll

Lead places head back, and nods head forward for brake release.

#### Gear up:

Clenched fist with thumb extended upward. Upward motion of the hand. Signal for execution is a backward head nod. Alternate execution signal is gear movement.

#### Gear down:

Thumb extended pointing down. Downward motion of the hand. Signal for execution is a head nod. Alternate signal for execution is gear movement.

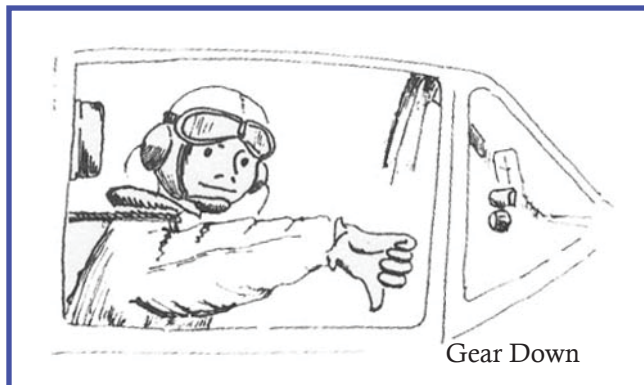

#### Reform or tighten formation:

Rock wings slowly.

#### Place formation to route:

Gently fishtail the aircraft with rudders.

#### Frequency change:

Tap helmet near the ear.

Extend fingers vertically for digits 1 through 5, horizontally for digits 6 through 9. Pull hand down out of sight between digits. Signal zero with a clenched fist. If using a briefed channel or tactical frequency, tap helmet and extend appropriate number of fingers (i.e. second tactical frequency, use two fingers).

#### Fuel/Ops check:

Close fist with thumb extended and perform drinking motion with thumb touching the oxygen mask or lips.

**Fuel remaining response:**

In response to fuel check, provide time above bingo as follows:

- 1 finger = 10-19 minutes
- 2 fingers = 20-29 minutes
- 3 fingers = 30-39 minutes
- 4 fingers = 40-49 minutes
- 5 fingers = greater than 50 minutes

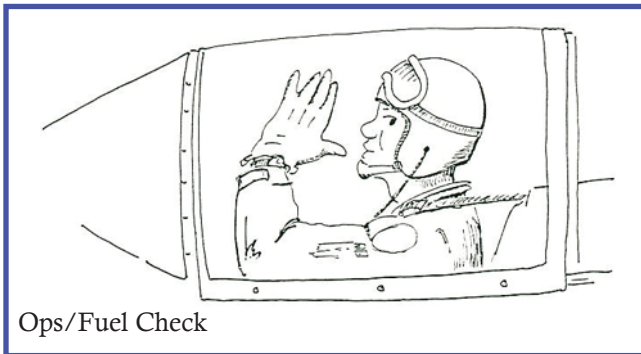

Ops/Fuel Check

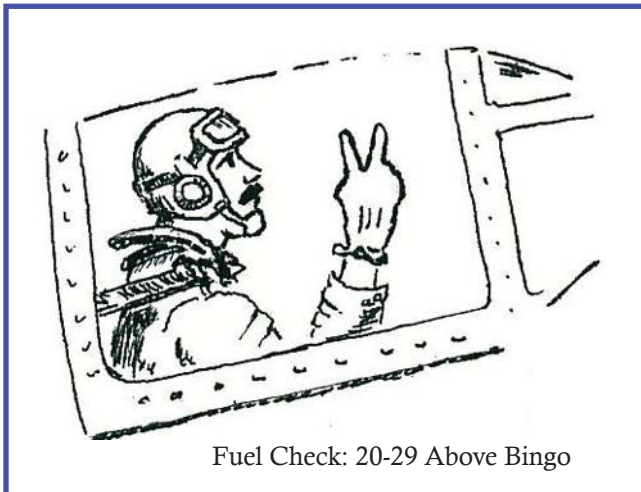

Fuel Check: 20-29 Above Bingo

**Cross Under Wingman**

Hold clenched fist up, arm bent 90 at elbow, hold until acknowledged by wingman.

**Cross Under Second Element:**

Clenched fist held up with arm bent 90 degrees at the elbow, pump up and down twice. Look for acknowledgment or repeat.

Cross unders may also be signaled by a small and quick wing dip in the desired direction of movement. Each wing dip moves one aircraft.

**Echelon Turn:**

When in two ship, use a clenched fist with forefinger and little finger extended upward. Move hand forward and aft repeatedly along canopy bow. Do not confuse with landing lights.

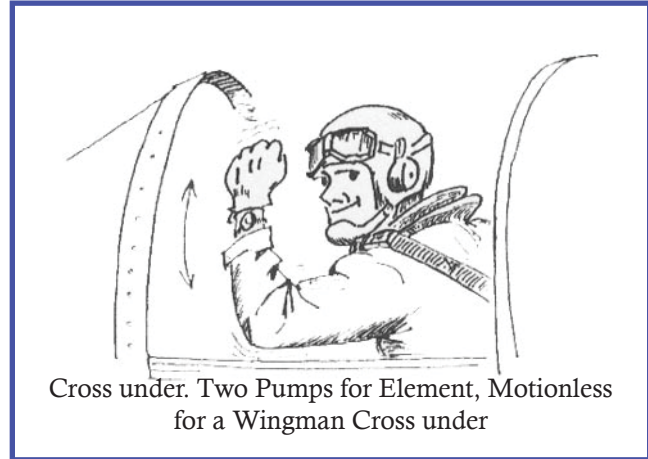

Cross under. Two Pumps for Element, Motionless for a Wingman Cross under

**Wingman to Close Trail:**

Clenched fist with thumb extended aft, motion aft. Provide signal to number two first, followed by number three. Alternate may be signaled by porpoising the nose.

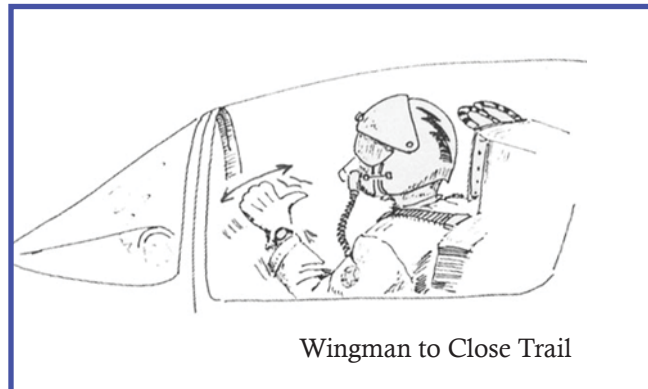

Wingman to Close Trail

**Wingman to Diamond:**

Hold four fingers up (all but the thumb), followed by clenched fist with thumb extending aft with aft motion of the hand. Provide this signal to number three, who will relay to number four.

**Flaps Up or Down:**

Biting motion with hand; fingers and thumb opening and closing (T-34 manual).

**Speed Brake Extend/Retract:**

Hand flat, palm forward with head nod for execution. (T-34 manual).

**Signal to Power Up/Power Back In-Flight:**

Clenched fist forward or backward motion.

**Change Lead:**

Point to the wingman to assume lead, followed by several pointing motions forward. Aircraft assuming lead acknowledges the signal with a head nod, moves to route and then moves forward, tapping head and pointing forward to signal to all flight members "I have the lead".

**Pitchout:**

Lead holds up index finger vertically and rotates to signal pitchout. If a specific interval is desired, follow immediately with number of fingers held vertically corresponding to the time in seconds between aircraft. Just prior to the pitchout, provide a “kiss off” signal by moving fingers away from the lips.

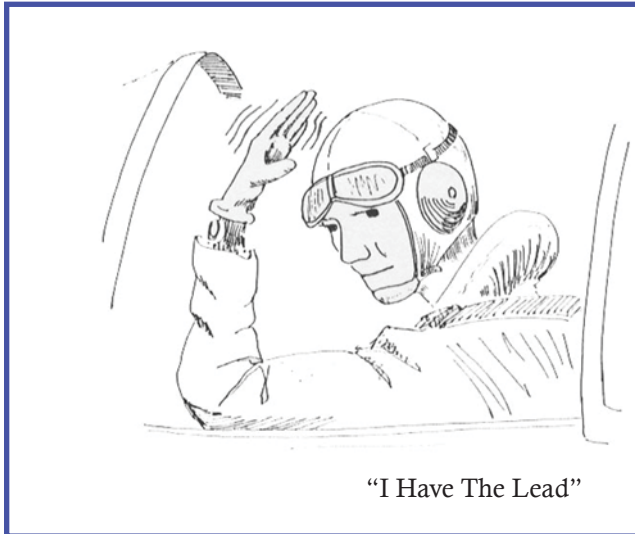
**Attention in the Air:**

Wing Rock. Also used to reform the flight to fingertip.

**Turn Squawk Off:**

Place hand around neck as if choking ones self.

**Turn Landing Lights On/Off:**

Use pinky and pointer fingers extended vertically with clenched fist at eye level. To signal landing lights off, reverse signal with fingers pointing down.

**Oxygen Check:**

Cup hand over mask followed by “ok” sign.

**Wingman to Tactical Formation:**

Porpoise nose of aircraft. Do not confuse with the aircraft signal to close trail which is also the nose porpoise; brief mission accordingly.

**Emergency Signals:****Aircraft Damage Check:**

Hold clenched fist with index finger and thumb extended, back of hand towards canopy.

**Bailout or Ejection:**

One or both clenched fists pulled downward across the face to simulate pulling an ejection face curtain.

**Descend to a Lower Altitude:**

Hand at top of canopy, palm flat, facing down and move

hand forward and down.

**Descend and Land Now:**

Movement of the hand, flat with palm down forward and down, finishing the movement by rounding out.

**I Must Land on Your Wing:**

Use your right hand, palm down, to tap your left shoulder or visa versa. Distressed aircraft lands, lead aircraft goes around when all landing coordination is complete and normally no lower than 300 feet.

**Radio Failure:**

Hand flat, fingers together, waved across the mask or mouth to indicate no transmitter. Wave across the ear to indicate no receiver. Perform both to indicate No Radio (NORDO).

**System Failures (HEFOE):**

Used when experiencing radio failure. Clenched fist held up, with back of hand touching the forehead in a “woes is me” signal. Followed immediately with the number of fingers extended vertically corresponding to the system malfunctioning:

One = Hydraulic/Pneumatic

Two = Electrical

Three = Fuel

Four = Oxygen

Five = Engine

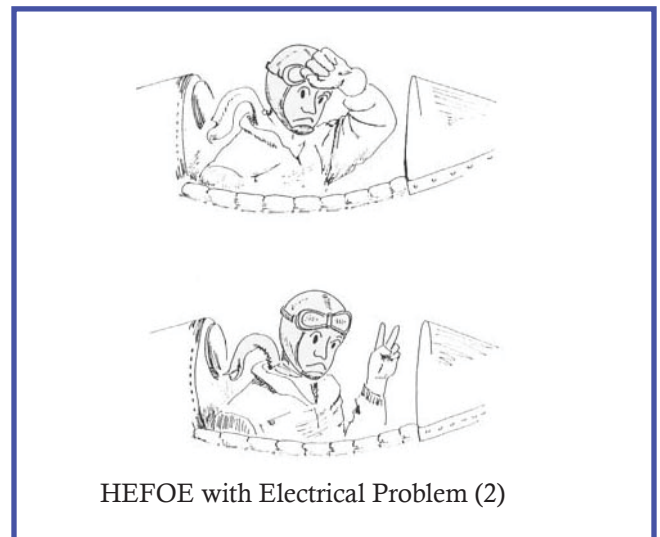

## APPENDIX B

### Formation Glossary

**ACUTE:** The opposite of “sucked.” To be in a position too far forward in the formation or on a bearing (angle) that would place the aircraft too far forward during rendezvous, creating an uncomfortable closure rate and angle for the joining aircraft; vis. an “acute’ rendezvous bearing as compared to a “sucked’ rendezvous bearing.

**ASPECT ANGLE:** The angle from the leader to the wingman, measured from the leads six o’clock. Wingman heading has no bearing on AA. Flying directly aft of lead is zero degrees aspect, abeam is 90 degrees and directly in front is 180 degrees AA.

**ANGLE OFF (AO):** Also called Heading Crossing Angle (HCA). The angular difference between the longitudinal axis of leader and wingman. The difference in headings between aircraft.

**ABORT:** Directive to cease current operation or inform others of your intentions, such as during an aborted formation takeoff.

**ALPHA CHECK:** Term to request a bearing and range to the target, as in when lead loses his bearings and radios, “Raven 2, request alpha check to field”

**BOGEY:** A visual contact who’s identity is unknown.  
**CONTINUE:** Directive instruction to continue maneuvering.

**BUTTON:** Term describing a preset frequency, as in “Raven Flight go button 2”

**BEARING LINE:** The line angled off the lead’s nose as flown by the wingmen.

**BINGO FUEL:** The fuel state at which the flight must return to base. A predetermined fuel figure remaining in gallons, pounds, or minutes which will allow return to base plus sufficient overhead reserve. When the wingman signals bingo fuel, the leader acknowledges and heads for base.

**CALL SIGN:** The word and position number that designates a flight and the members in it. Usually selected by the flight leader for that particular mission, such as “Raven Flight”. During flight, the lead is referred to by his/her position number; “Raven 1”, as are all flight members (Raven 2, Raven 3...).

**CLOSURE RATE (Vc):** Overtake created by airspeed or angular advantage between lead and wingman. Can be positive or negative.

**CROSSUNDER:** A maneuver to change the position of a

wingman from one side of lead to the other.

**DASH ONE, TWO, THREE, FOUR:** A US Navy term to refer to successive wingman in a flight.

**EXTENDED TRAIL:** A two ship fluid maneuvering exercise to teach in and out of plane closure control to formation pilots. Places the wingman between 30 and 45 degrees aspect angle with range based on maneuvering speed. Extended trail may include maneuvers such as barrel rolls, wingovers (modified lazy eights), loops, half Cuban Eights and the Cloverleaf if pilots are so equipped, certified and trained.

**ELEMENT:** A flight of two aircraft. The section is the basic fighting element and is self-supporting covering each other’s six o’clock in combat (real or otherwise), and providing back-up on routine flights with radio or equipment malfunctions in addition to moral support and good company. US Navy historically refers to this as a Section,

**ENERGY (E):** A term describing the current state of conditions in regards to altitude and airspeed of an aircraft. Altitude reflects an aircrafts potential energy, while airspeed reflects kinetic energy. Either may be transferred between the two as required.

**FLIGHT INTEGRITY:** The ability of the wingman to maintain proper relative position while the flight is maneuvering.

**FLIGHT:** In the basic form - four aircraft, consisting of two elements, each with it’s own leader. Under the command of the first element, who’s pilot is designated the “flight leader.” The flight is usually led by the most experienced pilot, with the second element leader as his deputy flight lead. USN may refer to this as a Division.

**FLUID MANEUVERING:** The opposite of Parade/Close/Fingertip formation. Aircraft fly defined range and offset parameters, but maneuver relative to one another. Extended Trail and Tail Chase are Fluid Maneuvering formations

**FLUID FOUR:** A formation consisting of four aircraft in which the element leads fly a tactical position off one another and the wingmen fly extended trail position off their respective element leaders.

**FORMATION:** A disciplined flight of two or more aircraft under the command of a flight leader using a standardized set of signals and commands to direct the wingmen. Not to be confused with a GAGGLE of aircraft.

**FIGHTING WING:** Nearly identical to the Extended Trail concept and used interchangeably in this manual. A posi-

tion of mutual support between two aircraft that allows maximum maneuverability and look out between element lead and wingman. During Tactical Formation using Fluid Four procedures, the element wingman are flying a fighting Wing position off their respective element leads.

GAGGLE: An undisciplined group of aircraft, milling about in roughly the same piece of sky, sometimes attempting to impersonate a FORMATION.

“GIMME ONE”: What the wingman calls to the lead when he has insufficient power to keep up, asking for lead to reduce power by one inch or more of manifold pressure/reduce EGT, RPM or burner setting in jets as applicable.

GO: Used to direct the flight to switch to a new frequency after acknowledging with call sign and or position number, in-sequence. See also “Push”.

HEADING CROSSING ANGLE (HCA). Also referred to as ANGLE OFF (AO). The angular difference between the longitudinal axis of leader and wingman.

HI YO YO: A maneuver performed out of plane with lead to control excessive closure, decrease aspect and prevent an overshoot.

INITIAL: As in initial approach. Refers to the approach on runway heading used when doing a 360 overhead break.

IN-TRAIL: A multi-ship fluid maneuvering formation where each aircraft follows the other. See also Tail Chase.

JOKER: The fuel state at which formation time must be prioritized to meet mission objectives. Joker will be briefed by the Flight Lead and may be in time or volume.

KNOCK IT OFF/TERMINATE: Terms used to cease maneuvering.

LAG ROLL: A rolling maneuver executed from a trail position, performed opposite the direction of target turn in an attempt to reduce aspect angle and control closure.

LIFT VECTOR: An imaginary plane going vertically through the top of the aircraft, representing the plane of motion in a straight pull. “Set the lift vector” means to roll the aircraft to set the point you want to pull to at your 12 o'clock high.

LINE OF SIGHT (LOS): A direct line between two aircraft as seen through the canopy.

LOS RATE: The rate of change in position of an aircraft in the canopy caused by relative motion between lead and wingman.

LAG PURSUIT: Manuever to increase distance between lead and wingman by pointing wings nose aft of leads tail to fly a larger turn circle.

LEAD PURSUIT: Manuever by wing to decrease distance to lead when the leader is in a turn. Wing maneuvers inside leads turn by pointing the aircraft nose in front of lead.

LOST WINGMAN: Term used by the wingman when he has lost sight of lead while flying in IMC.

LOW YO YO: A maneuver performed out of plane with lead to reduce excessive range. This maneuver usually increases aspect and closure.

NOSE TO TAIL OVERLAP: As viewed from above, the nose of the #2 aircraft is farther forward than the tail of the #1. Naturally, as long as there is lateral separation between aircraft, no danger exists.

NO JOY: Used to indicate that you have not visually acquired whatever it is you are looking for.

BLIND: Call when you have lost sight of the lead or reference aircraft.

OPS CHECK: Periodic check of aircraft systems and fuel state.

OVERSHOOT: A maneuver to allow a wingman to pass behind and below leads plane of motion when closure is excessive during a rejoin. The USN refers to this as an underrun.

OFFSET TRAIL: A maneuver and training formation completed in two ship that places the wingman 45 degrees aspect angle either side of the lead aircraft. Similar to Extended Trail, however restricted to in-plane (non aerobatics) maneuvering with the wingman stepped down at all times.

PARADE: Formation configuration to be used when under observation by the public, as in an airshow appearance. Parade formation is demanding, since the aircraft are in close physical proximity to each other. It requires absolute concentration on the part of the wingmen and smooth leadership by the flight lead. “Close” and “fingertip” formation also describes this flying style. The aircraft are “welded” together and fly as one unit.

PLANE OF MOTION: An imaginary plane defined by the aircraft’s flight path.

PUSH: Go to designated frequency without acknowledgment. Used in lieu of “Go”, which requires an acknowledgment by all wingmen before changing frequencies.

PADLOCKED: Term used when you can not look away from a target (another aircraft, ground observation point, etc.) or



you will lose visual on that object.

PERCH: The point during the overhead pattern that each aircraft initiates the turn to base.

REJOIN: To join the flight onto the leader, as after takeoff. USN historically refers to this maneuver as a Rendezvous,

ROUTE: A much looser version of fingertip formation. It allows the leader to control the flight, and reduces fatigue on the wingmen. Wingmen maintain the same relative bearing on the leader but move out two wingspans to 500 feet.

ROE: Rules of Engagement. The agreed upon rules the members will operate under.

STEP DOWN: The #2 aircraft is positioned a number of feet lower than his/her element lead. This allows room to maneuver in case of abrupt turns into the wingman.

STEP UP: What the thinking wingman does when the leader's making low passes!

SUCKED: To fall behind the lead, or be aft of the desired position. Aft of the bearing line.

SMASH: Airspeed or Energy. Normally used to denote energy available to accomplish a snappy fighter-type maneuver, such as a pitchup to landing.

SOP: Standard Operating Procedures. Those procedures that should be understood and used unless briefed differently by the flight lead.

TACTICAL FORMATION: A formation consisting of two or more aircraft maneuvering approximately one turn radius apart.

TALLY HO: Used to indicate that you have visually acquired whatever it is you were looking for.

TAIL CHASE: Alternate term for a multi-ship fluid maneuvering formation where each aircraft follows the other. See also "In Trail."

THE BREAK: The breakup of the formation over the runway when a flight does a 360 OVERHEAD. Also called a "pitchout." A fighter maneuver indicating an abrupt bank and pull to accomplish a change of direction and/or altitude.

TURN CIRCLE: The flight path described by an aircraft in a turn. The size of the turn circle is based on bank angle, load factor and velocity.

TURN RADIUS: The distance from the aircraft to the center of his/her turn circle.

TURN RATE: The rate of heading change by an aircraft.

VISUAL: Call when you have the leader or reference aircraft in sight.

3/9 LINE OVERSHOOT:  
When your aircraft moves ahead of the leader.

WINGTIP OVERLAP: No lateral separation exists.

## APPENDIX C

### Briefing and Debriefing Skills

#### C1 Briefings

The team concept of mutual support requires an effective communication process within, and among, the flight. This begins with the formal briefing and does not end until conclusion of the debriefing well after the flight.

#### C2 Formation Briefing

The flight lead will ensure the flight objectives, weather, sequence of events and communications are briefed before every formation flight. Qualified formation pilots are expected to have memorized the standard operating procedures contained in this manual, thus mission elements may be briefed as “standard” provided they are published and the proficiency level of all flight members allows them to be briefed as such. Non standard procedures and information unique to the mission will be briefed in detail. As a minimum, review the formation briefing guidance contained in Appendix C.

It is essential for the flight members to discuss how the flight will be conducted so that everyone knows what to expect and what is expected of them - no questions should be unresolved when your team steps to board their aircraft. Always strive to fly the plan as briefed. Leads will strive to use a briefing checklist card similar to the one contained in this appendix. Wingman will be prepared to take notes for reference.

#### Flight Lead

For the flight lead, the brief starts well before the pilots assemble in the room. You must have a full command of the plan; what are your objectives? What will your team expect to see and accomplish during the flight? To achieve this, flight leads should visualize the entire mission from engine start to shut down. This is often termed “chair flying” the mission, and is a critical step in preparing to brief your flight. Based on the active runway, what is the preferred routing to the runway? How will you depart the local area? What sequence of maneuvers will you fly? What if the weather impacts your mission? How will you handle a flight member bailout or crash landing? Continue this process to engine shutdown to insure you know the plan thoroughly- it’s your plan and your wingmen will expect you to have the answers.

Set a professional tone early in your brief and create an environment where the flight members can focus on your plan without undue distractions. Establish early on if you want questions raised “on the fly” or held until you call for them in wrap up. While you should be open to suggestions that may help achieve your objectives, be wary of constantly changing or modifying your plan to appease the audience. This generally leads to confusion and poor execution.

#### Wingmen

It’s vital that you’re prepared for the mission briefing and on time. Formation is a skill set that requires above average flight discipline from all members and this starts in the briefing. Bring something to take notes. In general, if you have a question, avoid interrupting the briefing and write the question on your line up card or scratch paper and raise the topic when the lead calls for questions or in the wrap up. It’s vital that you never leave the flight brief with an open question on the days mission, so when in doubt, ask! Feel free to offer assistance to lead with preparing the brief by collecting weather data, abort field information, etc. Formation is always a team effort.

#### C2.1 Formation Briefing Outline

The following general steps were developed over many years of flying the most complex missions by USAF and Navy fighter squadrons and are very applicable to our formation flying. This outline is represented on the RPA Formation Briefing Card available for download on our web site.

##### Step 1: Time hack.

Brief on time! The goal of every formation flight is the pursuit of flawless execution, and that always begins with the briefing. Introduce yourself and your flight mates and then establish the time hack immediately. Synchronizing watches is not only important to meeting target times like engine start, but in our world the time hack is that singular action that symbolizes it’s time to focus on one thing and one thing only; executing the formation plan.

##### Step 2: Establish the Mission Objectives

All flight members are tuned in, now set the objective for the mission. In one sentence your objective should be clear, measurable and achievable. If you have secondary objectives, insure they are established up-front as well.

“Today Raven Flight will practice four primary mass formation configurations over the Hamilton Airfield and complete an annual currency flight for number 3”.

##### Step 4: Weather and Environment

Weather, terrain and airspace restrictions will impact every formation mission and should be covered early. Do not simply read the Terminal Area Forecast (TAF) or METAR to your flight; apply the information to your mission! How will the surface winds effect your formation takeoff and departure? Will the ceiling and visibility allow for the maneuvers your flights expecting, or should you be briefing a back up plan? Finally, take a look at the weather forecasted for your destination/return. Explain how to properly fly the overhead with the forecasted crosswinds; if they are un-

dershooting at the break and thus overshooting during the base turn to final, explain to your wingmen how the pattern should be adjusted. Finally, determine if conditions should effect your bingo or divert options.

### Step 5: Sequence of Event

The next portion of the briefing lays out the general timeline and sequence of the flight. In doing so, the Flight Lead will avoid restating standard operating procedures and may address such items as “Standard”, to indicate the procedures will be in compliance with this manual. These are the procedures you will learn here and in training that rarely change unless the Lead sees a need. If Lead intends to alter the standard procedures for the flight, he/she must thoroughly brief the changes.

“Raven flight, engine start is planned for 0900 on my visual signal, check in on 121.7 to follow. Engine start, taxi and element takeoff with a left hand turn out of traffic will be standard, any questions?”

### Step 6: Contingencies

While we can not plan for every possible emergency, contingency plans are the result of the Flight Lead asking him/herself “what if?” What if #3, your deputy lead, ground aborts for maintenance, what if a wingman aborts on takeoff roll or during flight encounters a bailout situation, You just finished briefing the sequence of your plan, now brief key information to help manage events when the sequence doesn’t go according to that plan. If you have a minimum “Go, No-Go” criteria as it applies to any parameter such as weather, minimum aircraft, etc., brief it here.

### Step 7: Mission Execution

This is the meat of the briefing and will take up the remainder of your brief time. Your flight members know the mission objectives, the environment they will be operating in, and your back up plans; now discuss how you intend to accomplish the primary objectives in detail—in the same sequence you will fly them. Hard decks are set, maneuver limits are established, rejoin speeds are briefed; when you conclude this portion of the brief, your wingmen not only know what you want to accomplish (objective), but now know how you expect the flight to accomplish it.

### Step 8: Wrap Up & Questions

We want to make sure that no one has a question, that there is no confusion when we step for our aircraft. Make sure that you never walk out of the flight briefing with a question in your mind on how you’re going to execute the mission. That’s the accountability loop that will start our post mission debrief. If you planned correctly, you’ve wrapped up the brief with enough time to give the flight members a chance to hit the head and grab a snack before they step—it’s time to execute the plan!

See the Formation Briefing Guide in this Appendix.

## C3 Formation Debriefing

Even though the mission is over, the learning isn’t. After everyone has a chance to secure his/her aircraft, the flight members assemble for the debrief. This is a critical tool of the formation program.

### C3.1 Formation Debriefing Outline

The formation lead should set a tone for open communication and analysis of lessons learned in the debrief, sequentially stepping through each phase of the flight. All aspects of the flight are critiqued, with emphasis on what occurred, why it occurred and how to improve in the future. Make sure all questions are answered and uncertainties are resolved. The following are some general guidelines in conducting a formation debrief:

#### Step 1. Begin by restating the Objectives

Simple enough, you left the flight brief with a plan to meet a clear, measurable and achievable objective. Restate your objectives; use the debrief to determine how well your flight executed those objectives.

#### Step 2. Keep the debrief Brief

Do not debrief every step of the flight, but concentrate on those areas where the flight could improve with analysis and shared learning. Your flight members will begin to tune out immediately if the debrief becomes a long, step by step, reconstruction of the standards. In choosing what to debrief, ask yourself the question; can learning take place? If everything went as planned, or no training will be accomplished by discussing it, simply move on in the debrief.

#### Step 3 Conduct a Nameless Debrief

The idea is to identify and correct errors, not attack our team mates. In general, use the third person speaking approach during the debrief. Let’s say “Bob” was out of position and excessively low in the third rejoin. In a nameless debrief, lead would state “Number 2 was consistently low on rejoins, causing the second element to adjust”, this would be followed by how to correct the error as needed. Bob is reduced to a position—he’s just number two in the flight. That’s a powerful tool to keep the focus on correcting mistakes and not a personal attack. We would never say “Bob, you were way out of position during all rejoins, you need to keep up with the rest of us”. That will guarantee to put your wingman on the defensive and negatively impact the learning process in the debrief.

#### Step 4 Conduct a Rankless Debrief

This is not the military, but formation flying has recognized positions; leads, wings, instructors and check pilots. We may also have significant differences in age, flight hours and backgrounds. All of which may impact the communication process. In a rankless debrief, the lead sets the tone that

we are all equals in learning. This is a process, not a competition. The goal is to improve future execution, not make ourselves look good or protect an image among peers. Leave that for the tall tales outside the debrief.

#### **Step 5 Use a What, Why and How Debrief Approach**

The goal of the debrief is to analyze execution, identify lessons learned, and improve on the next sortie. Leads and instructors must be capable of reconstructing what went wrong, be prepared to explain why the deviation occurred, and finish with how best to correct the discrepancy. The debrief is an instructional event.

End it on a high note

#### **Step 6 End It On A High Note**

After dissecting the flight, admitting errors and analyzing lessons learned, end the debrief on a very high note. Formation is fun, if it wasn't, we wouldn't be here.

#### **NOTE**

If the debrief reveals areas that need clarification or improvement in the Standard Operating Procedures contained in this manual and other program documents, please communicate such recommendations to the association.

### **C4 Summary**

Managing effective formation briefing and debriefing is one of the unique skill sets of the successful formation leader. The results of your investment in this skill is more a more effective leadership of your flight, vastly improved communication among the flight members.

# APPENDIX D

## Program Forms and Documents

### D.1 Introduction

The RPA produces several forms and documents to assistance formation pilots. All are available in Adobe PDF format at the association web site, [www.flyredstar.org](http://www.flyredstar.org). The following may be photocopied and used as needed in your training.

### Sortie Knee Board Card:

## SORTIE CARD

Flight Call Sign: \_\_\_\_\_

#1: \_\_\_\_\_ #3: \_\_\_\_\_  
Assigned Flight Lead

#2: \_\_\_\_\_ #4: \_\_\_\_\_

Start Time: \_\_\_\_\_ Bingo: \_\_\_\_\_  
Day VFR: 30 Minutes Minimum Reserve

**Communications**

**Briefing Notes**

Tac 1: \_\_\_\_\_

Tac 2: \_\_\_\_\_

Atis: \_\_\_\_\_

Gnd: \_\_\_\_\_

Twr: \_\_\_\_\_

AirBs: \_\_\_\_\_

Other: \_\_\_\_\_

### Metric Conversion Tables

KTS	MPH	KPH	In HG	Mm HG	In HG	Mm HG
50	58	93	15	381	28	711
60	69	111	16	406	29	737
70	81	130	17	432	30	762
80	92	148	18	457	31	787
90	104	167	19	483	32	813
100	115	185	20	508	33	838
110	127	204	21	533	34	864
120	138	222	22	559	35	889
130	150	241	23	584	36	914
140	161	259	24	610	37	940
150	173	278	25	635	38	965
160	184	296	26	660	39	991
170	196	315	27	686	40	1016
180	207	333				
190	219	352				
200	230	370				

This card belongs to: \_\_\_\_\_

## Sortie Briefing Card:

<b>STEP 1: TIME HACK</b>	<b>STEP 6: EXECUTION</b>
<b>STEP 2: MISSION OBJECTIVES</b>	<i>COVER DETAILS AS REQUIRED:</i> Takeoff, Rejoin, Climb, Enroute. Maneuvers (in sequence of events) Lead change procedures Formation recovery and landings
Primary, Secondary and Training.	<b>STEP 7: WRAP UP</b>
<b>STEP 3: WEATHER &amp; ENVIRONMENT</b>	<i>SPECIAL EMPHASIS ITEMS:</i> Radio Discipline, FOD, Flight Control Checks, Maneuver Limitations, Rolling G/Over G Awareness.
Metar / TAF (departure/enroute/arrival) Airport wind analysis (departure/arrival) NOTAMS Airspace/ATC/Terrain issues	<b>Questions?</b>
<b>STEP 4: SEQUENCE &amp; STANDARDS</b>	-----
Flight Call Sign Position ID: Lead, #2, #3, #4 Other A/C (photoship, etc.) Dissimilar aircraft issues/concerns Preflight needs, fuel, air? (est. step time) Start, Takeoff & Control Times (if applic.) Frequencies (Tactical, Gnd, Twr, etc.) Mission Sequence Overview: - Start/Taxi/Takeoff - Working Area Sequence - Recovery / Landing - Debrief—Location Hard Deck / Altitude Block Fuel checks, Bingo, Joker Parachutes/Flight Suits/FAST Cards	<b>INDIVIDUAL CREW BRIEF:</b> Transfer of aircraft control Intercom failure Emergency checklist procedures Egress on ground Bailout procedures
<b>STEP 5: CONTINGENCIES</b>	-----
Alternate/Secondary mission Alternate Lead Drop Outs/Min Required Go-No-Go Weather Criteria Abnormal Procedures: - Takeoff & Departure: — Abort. Radio Calls & Proced. — Problem immediately after t/o - In Flight: — Collision — BDA — Bailout / Crash landing SAR — Chase / NORDO - Approach & Landing Emergency/Divert Fields HEFOE Signals (only if NORDO) Lost sight & break-out procedures Use of KIO vs. Terminate Calls	<b>MASS FORMATION BRIEF :</b> Mass formation call sign and individual flight call sign assignments Mass flight lead & individual flight leads Communication plan Smoke aircraft placement & procedures Parking & Taxi plan Runway line-up Takeoff (last ship airborne call) Assembly plan Formation maneuvers in sequence Pattern (box, dogbone, etc.) Stack, Symmetry, Offset, Interval Airshow box, crowd line/CAT show line Recovery Emergencies Practice walkthrough on ramp <b>Questions?</b>
	 <p><b>RedStar Pilots Assoc.</b> <i>Formation Briefing Card</i></p>

## RPA FAST FORMATION PROFICIENCY REPORT

### GENERAL INSTRUCTIONS – ALL PILOTS READ CAREFULLY:

The Formation Proficiency Report (FPR) records both a pilot's demonstrated currency and, more importantly, **his/her proficiency**. Accomplishing the objectives of the FPR requires a training event for both wing and lead rated pilots. The FPR is not valid unless flown in a **minimum of a three ship formation** (four ship is highly recommended). The endorsing pilot must be a current lead or check pilot, and may observe from any position or seat in the flight. However, a flight leader can not endorse him/herself, and must have another lead or check pilot observing. All lead rated pilots **are required to demonstrate both wing and lead proficiency**. Wing proficiency for lead rated pilots must include: Lazy Eights, Cross Under, Echelon Turn, Close Trail and Turning Rejoin as a minimum, and may be flown from any wing position. Reference the Formation Manual for an expanded explanation of maneuvers. Note: All flight members participating may be observed during a single flight and recorded using one form. **However, do not include the name of any pilot who has not completed all requirements of this FPR and demonstrated proficiency in all maneuvers flown and recorded below.** See below for fax/email instructions.

BLOCK I: OBSERVE AS MANY AS PRACTICAL	Req. Event*	BLOCK II: OBSERVE AS MANY AS PRACTICAL	Req. Event*
Mission Planning and Briefing (flight leaders)	●	Lead change/Position change	
Formation Ground Operations (start/taxi/runup)		Simulated Abnormal Operations - optional:	
Formation Takeoff - choose at least one:	●	-- Break out procedures and calls	
-- Single ship interval takeoff		-- NORDO procedures and signals	
-- Element takeoff		-- Blind/Visual Procedures and calls	
Flight assembly (element or interval takeoffs)	●	Formation Recovery - choose at least one:	●
Route position		-- Overhead traffic pattern to interval landings	
Lazy Eights at 40° ± 5 Angle of Bank (AOB)	●	-- Element approach and landing (nosewheel a/c)	
Cross-under	●	Element go-around	
Echelon turns at 40° ± 5 Angle of Bank	●	Formation communications (radio/visual)	●
Diamond at 40° ± 5 Angle of Bank (if four ship)	●	Formation Ground Operations (taxi/shutdown)	
Close trail at 40° ± 5 Angle of Bank	●	Situational Awareness and/or Leadership	●
Extended trail < 90° AOB/Pitch if non-aerobatic		Flight Debriefing	●
Pitchout and rejoin at 30° Angle of Bank	●	Formation flight instruction (flight leaders)	

PLACE A CHECKMARK TO INDICATE ALL OPTIONAL ITEMS FLOWN ABOVE. COMPLETE MANEUVER STANDARDS ARE FOUND IN THE RPA PTS.

### LIST ONLY PILOTS WHO HAVE COMPLETED ALL REQUIREMENTS FOR THE FPR – *NOT ALL MEMBERS OF A FLIGHT!!*

Pilot's name \_\_\_\_\_ Wing/Lead Cell/Home \_\_\_\_\_

Pilot's name \_\_\_\_\_ Wing/Lead Cell/Home \_\_\_\_\_

Pilot's name \_\_\_\_\_ Wing/Lead Cell/Home \_\_\_\_\_

Pilot's name \_\_\_\_\_ Wing/Lead Cell/Home \_\_\_\_\_

Additional names may be attached to this form      Circle current rating      Provide either form of contact information

### FLIGHT LEAD OR CHECK PILOT ENDORSEMENT

"I hereby ATTEST that I have observed the pilots listed on this form during flight in which all maneuvers indicated above were executed. I find all pilots listed above PROFICIENT and meet or exceed the minimum requirements in accordance with the RPA Practical Test Standards."

Name \_\_\_\_\_ Date flown (dd/mm/yy) \_\_\_\_\_

Signatory organization \_\_\_\_\_ Cell/Home \_\_\_\_\_

Endorsing signature (not valid FPR without signature) \_\_\_\_\_

## RPA FAST RECOMMENDATION FOR EVALUATION REPORT

### GENERAL INSTRUCTIONS – ALL PILOTS READ CAREFULLY:

The Formation Recommendation for Evaluation records a pilot's demonstrated formation **proficiency and readiness for the practical test for wingman or flight leader as indicated below**. The applicant must have completed all training and FF&P prerequisites before being recommended. The recommendation is not valid unless flown in a **three ship formation** (four ship is highly recommended). The endorsing pilot must be a current lead or check pilot, and may observe from any position or seat in the flight. Reference the Formation Manual for an expanded explanation of maneuvers. If the candidate successfully passes the recommendation ride, this form should be presented to an RPA check pilot for final evaluation. The FAST Recommendation for Evaluation form is retained by the RPA check pilot at the time of evaluation and is retained for record or destroyed at the discretion of the association.

### CANDIDATE INFORMATION:

Candidate name \_\_\_\_\_ Signatory \_\_\_\_\_  
 Candidate cell/home # \_\_\_\_\_ Aircraft type \_\_\_\_\_  
 Rating desired: Flight Leader:  Wingman:  Date of flown (dd/mm/yy) \_\_\_\_\_

BLOCK I: OBSERVE AS MANY AS PRACTICAL	Req. Event*	BLOCK II: OBSERVE AS MANY AS PRACTICAL	Req. Event*
Mission Planning and Briefing (flight leaders)	●	Lead change/Position change (flight leaders)	
Formation Ground Operations (start/taxi/runup)		Simulated Abnormal Operations - optional:	
Formation Takeoff - choose at least one:	●	-- Break out procedures and calls	
-- Single ship interval takeoff		-- NORDO procedures and signals	
-- Element takeoff		-- Blind/Visual Procedures and calls	
Flight assembly (element or interval takeoffs)	●	Formation Recovery - choose at least one:	●
Route position		-- Overhead traffic pattern to interval landings	
Lazy Eights at 40°±5 Angle of Bank (AOB)	●	-- Element approach and landing (nosewheel a/c)	●
Cross-under	●	Element go-around	
Echelon turns at 40°±5 Angle of Bank	●	Formation communications (radio/visual)	●
Diamond at 40°±5 Angle of Bank (if four ship)	●	Formation Ground Operations (taxi/shutdown)	
Close trail at 40°±5 Angle of Bank	●	Situational Awareness and/or Leadership	●
Extended trail <90° AOB/Pitch if non-aerobatic		Flight Debriefing	●
Pitchout and rejoin at 30° Angle of Bank	●	Formation flight instruction (flight leaders)	●

Mark all optional maneuvers flown above. Bank angles represent required standards as reflected in the RPA Practical Test Standards available through the association's website. Complete maneuver standards for the lazy Eight, Close Trail and Diamond formations are: 40° ± 5° Angle of Bank and 15° ± 5° of pitch.

### FLIGHT LEAD OR CHECK PILOT ENDORSEMENT

"I hereby ATTEST that I have observed the candidate listed on this form during flight in which all maneuvers indicated above were executed. I find the candidate listed above PROFICIENT and meets or exceeds the minimum requirements in accordance with the RPA Practical Test Standards. I recommend him/her for the rating indicated above"

Name \_\_\_\_\_ Signatory \_\_\_\_\_  
 Signature \_\_\_\_\_ Cell/home \_\_\_\_\_  
Not valid without signature



# RPA FAST FORMATION EVALUATION REPORT

**CANDIDATE INFORMATION:**

Candidate name \_\_\_\_\_ Signatory \_\_\_\_\_

Candidate cell/home # \_\_\_\_\_ Aircraft type \_\_\_\_\_

Evaluation: Flight Leader:  Wingman:  Date of Evaluation (dd/mm/yy) \_\_\_\_\_

BLOCK I - ORAL EVALUATION	S	U
Briefings – Content and structure		
Hand and Aircraft visual signals		
Element takeoff procedures		
Interval takeoff procedures		
Departure and form up procedures		
Route formation Procedures		
Finger Four formation Procedures		
Cross-under procedures		
Echelon formation procedures		
Diamond formation procedures		
Close Trail formation procedures		
Extended Trail formation procedures		
Pitch out & rejoin procedures		
Lead changes procedures		
Overshoot procedures		
3-ship vic (phantom four) procedures		
Overhead pattern procedures		
Element landing/go-around procedures		
Formation break out procedures		
Knock it Off and Blind-Visual Procedures		
Formation instruction (flight leaders)		

BLOCK II - FLIGHT EVALUATION	Req. Event*	S	U
Mission Planning and Briefing	●		
Formation Start/Taxi/Runup	●		
Formation Takeoff - choose at least one:	●		
-- Interval takeoff			
-- Element takeoff			
Flight assembly (element or interval takeoffs)	●		
Route	●		
Finger Four formation	●		
-- Lazy Eights in #2 (wingmen candidates)			
-- Lazy Eights in #4 (wingmen candidates)	●		
Cross-under	●		
Echelon	●		
Diamond (wingmen candidate in #4)	●		
Close Trail			
Extended Trail (non aerobatic)	●		
Pitchout and rejoin	●		
Overshoot (also termed "under-run")			
Lead change/Position change			
Simulated Abnormal Operations			
-- Break out calls and procedures			
-- NORDO procedures and signals			
-- Blind/Visual calls and procedures			
Formation Recovery - choose at least one:	●		
-- Overhead traffic pattern			
-- Element approach and landing (nosewheel)			
Element go-around			
Formation communications (radio/visual)	●		
Formation Taxi/shutdown			
Situational Awareness and/or Leadership	●		
Flight Debriefing	●		

**CHECK PILOT ENDORSEMENT:**

CP \_\_\_\_\_

CP signature \_\_\_\_\_

SAT:  UNSAT:  INCOMP:

**CHECK PILOT COMMENTS/RECOMMENDATIONS:**

INITIAL CHECK:  RECHECK:

*Continue on back of form as needed. If checkride is unsatisfactory, this form may serve as applicant's recommendation for recheck with training accomplished.*

\*Check pilots may ask to see any maneuvers listed here or in the RPA PTS. Any event not required above may be covered in oral eval at the discretion of the check pilot. Check pilots may evaluate flight leaders from any aircraft or seat in the formation. Check pilots will fly with all wingmen during their evaluation.

**CANDIDATE ENDORSEMENT:**

Signature \_\_\_\_\_

Fax or scan/email all evals to Shane Golden, RPA FAST Records:  
Fax 305-675-3940 Email scgsmg@bellsouth.net

<b>RPA Formation Training Matrix: Flight Leader</b>									
<b>INSTRUCTOR'S INDIVIDUAL MANEUVER REMARK CODES:</b>									
<b>D = IP Demonstrated X = Student Performed S = Safe Execution P = Proficient Execution</b>									
MISSION NUMBER / AIRCRAFT IN FLIGHT: 2, 3, or 4:									
<b>FORMATION MANEUVERS :</b>	1	4							
Mission planning (weather, complexity, etc.)	D								
Mission briefing presentation									
Formation engine start procedures									
Formation taxi and runup									
Interval takeoff and flight assembly									
Element takeoff and flight assembly									
In-flight frequency change procedures (comm-in)									
In-flight frequency change procedures (comm-out)									
Route formation - use and execution									
Crossunders									
Phantom Four procedures									
Echelon (Echelon turns at 40°±5° Level Pitch)									
Close trail at 40°± 5° AOB and 15°±5° Pitch									
Extended trail - 2 ship (wingman management)*									
Pitch-out & rejoin (at 30° AOB for turning rejoin)									
Managing wingman overshoot									
Managing wingman break out									
Managing Simulated emergencies (KIO, NORDO, Lost Sight, Bailout, Chase Ship Procedures)									
Lead change procedures and execution									
Overhead pattern execution and landing									
Airport traffic awareness/planning									
Element configuration change (gear/flaps)									
Element approach									
Element landing and roll out (nosewheel only)									
Element go around									
Formation taxi in and shutdown									
Overall Flight radio procedures (brevity, clarity, etc.)									
Overall Hand signal use and recognition									
Overall Coordination with ATC									
Overall In-flight situational awareness									
Management/execution of the debrief									
Table top instruction skills (pick one topic each flight)									
<b>FOUR SHIP REQUIRED MANUEVERS:</b>									
Flight Manual runway lineup options and use									
Diamond at 40°± 5° AOB and 15°±5° Pitch									
Finger Four at 40°± 5° AOB and 15°±5° Pitch									
Four Ship Extended Trail < 90° AOB/Pitch*									
<b>INSTRUCTORS OVERALL RECOMMENDATION:</b>	C								

**C = Continue S = Solo R = Send for Recommend Ride EVAL = Recommend for Check Ride!**

<b>RPA Formation Training Matrix: Wingman</b>									
<b>INSTRUCTOR'S INDIVIDUAL MANEUVER REMARK CODES:</b>									
<b>D = IP Demonstrated X = Student Performed S = Safe Execution P = Proficient Execution</b>									
MISSION NUMBER / AIRCRAFT IN FLIGHT: 2, 3, or 4:									
<b>FORMATION MANEUVERS :</b>	1	4	/	/	/	/	/	/	/
RPA Manual General Knowledge	D								
Mission briefing - Input and retention									
Formation engine start procedures									
Formation taxi and runup									
Interval takeoff and flight assembly									
Element takeoff and flight assembly									
In-flight frequency change procedures (comm-in)									
In-flight frequency change procedures (comm-out)									
Route formation									
Crossunders									
Phantom Four procedures									
Echelon (Echelon turns up to 40°±5° Level Pitch)									
Close trail up to 40°± 5° AOB and 15°±5° Pitch									
Extended trail (non aerobatic: < 90° AOB/Pitch)*									
Pitch-out & rejoin (at 30° AOB for turning rejoin)									
Rejoin overshoots - Turning									
Rejoin overshoots - Straight Ahead									
Simulated Abnormals KIO, NORDO, Lost Sight (blind-visual calls), Break Out, Chase.									
Lead / position change procedures and execution									
Overhead pattern execution and landing									
Airport traffic awareness									
Element configuration change (gear/flaps)									
Element approach									
Element landing and roll out (nosewheel only)									
Element go around									
Formation taxi in and shutdown									
Overall Flight radio procedures (brevity, clarity, etc.)									
Overall Hand signal use and recognition									
Overall Coordination with ATC									
Overall In-flight situational awareness									
Debrief-attitude and input									
<b>FOUR SHIP REQUIRED MANUEVERS:</b>									
Flight Manual runway lineup options and use									
Second element rejoins (#4)									
Diamond slot up to 40°± 5° AOB and 15°±5° Pitch									
Finger Four at 40°± 5° AOB and 15°±5° Pitch (#4)									
Four Ship Extended Trail < 90° AOB/Pitch (#4)*									
<b>INSTRUCTORS OVERALL RECOMMENDATION:</b>	C								
<b>C = Continue S = Solo R = Send for Recommend Ride EVAL = Recommend for Check Ride!</b>									

